



REMEDIAL ACTION

REPORT

SITE 0153

INDIANAPOLIS, INDIANA

U.S. EPA ID NUMBER: INN000510936

PREPARED BY:

INDIANA DEPARTMENT OF ENVIRONMENTAL MANAGEMENT

OFFICE OF LAND QUALITY

STATE CLEANUP PROGRAM

October 1, 2021

**REMEDIAL ACTION
REPORT
SITE 0153
INDIANAPOLIS,
INDIANA
U.S. EPA ID NUMBER: INN000510936**

INTRODUCTION

This Remedial Action Report (RAR) documents that the Indiana Department of Environmental Management (IDEM) has completed the requirements for the Riverside Groundwater Contamination Site (“Site 0153” or “Site”) 2017 Memorandum of Agreement (MOA) between IDEM and the United States Environmental Protection Agency (U.S. EPA).

Remedial actions taken at the site include removal of production well WR-3 from service in September 2016, due to the detection of exceedances of the U.S. EPA Maximum Contaminant Level (MCL) of Trichloroethylene (TCE) in the raw groundwater. An aeration system was installed as an interim remedy to remove contaminants from the raw groundwater from WR-3 before it is mixed and treated by Citizens Water (Citizens) for distribution. Production Well WR-3 was returned to service in April 2020 after sampling confirmed effective operation of the interim remedy. Contaminant concentrations in all active production wells are currently below MCLs and have been for the last five years. Remediation Goals (i.e., MCLs) have been achieved at the individual production wells and the White River and Riverside Municipal Wellfields, at large. Quarterly monitoring will continue at the production wells and a remedy has been selected should a production well have MCL exceedances for volatile organic compounds (VOCs) in the future.

IDEM has met the requirements of the MOA, and the production wells and Wellfields, which are the subject of this RAR, require no further action. Remediation at State Program sites within the 5-year time of groundwater travel from the Wellfields will continue to be overseen by IDEM. IDEM has determined that the activities completed at the Site are protective of human health and the environment, and acknowledges that finished drinking water provided to Citizens’ customers has always met, and continues to meet all the requirements of the Safe Drinking Water Act (SDWA).

I. BACKGROUND

Site Description

Site 0153 (U.S. EPA ID# INN000510936) is located in Indianapolis, Marion County, Indiana and consists of an area of marginally impacted groundwater in the vicinity of the Riverside and White River Municipal Wellfields (Wellfields). The Wellfields are operated by Citizens, the public drinking water supply utility for the City of Indianapolis. In 2013, Citizens notified IDEM that low levels of chlorinated volatile organic compounds (cVOCs) had been detected in untreated “raw” groundwater samples collected from certain water production wells in the Wellfields. In 2014, IDEM sampled and found low levels of cVOCs

in five of the 17 production wells. With the exception of production well WR-3, all cVOC concentrations in raw groundwater were below and have remained below their respective MCLs. As part of its drinking water operations, Citizens mixes raw groundwater from the Wellfields with surface water from the Indianapolis Central Canal, which is then treated and filtered, creating the “finished water” distributed to the public. The finished drinking water provided to customers by Citizens has always met and continues to meet the SDWA.

The cVOCs have migrated to the Wellfields from off-Site source(s) within the Site 0153 area. The Wellfields are in an urban mixed-use area of the city where dozens of historic industrial facilities, which potentially used cVOCs, operated over the course of several decades. In order to address the impacts to the Wellfields, IDEM is managing potential individual sources within Site 0153 through one of the various state remediation programs. IDEM initially identified 89 potential sources of cVOC impacts within the 5-year time of groundwater travel to the Wellfields; however, a definitive source(s) of cVOCs impacting the Wellfields has not been identified to-date. It is likely that several individual sources have contributed to a commingled groundwater plume which led to the low-level cVOC impacts detected in certain production wells in the Wellfields. Individual Potentially Responsible Parties (PRPs) have been and will be responsible for conducting their own site investigations and remediation, under directive and oversight from IDEM, to address their cVOC impact contributions to the two Wellfields. Individual PRPs will also be responsible for addressing any other site-specific associated risks, such as vapor intrusion exposure, separately from Site 0153.

In accordance with the MOA, IDEM completed a Remedial Investigation (RI), Human Health and Ecological Risk Assessment (HHERA), and a Feasibility Study (FS) as part of Site 0153 efforts. The RI characterized Site conditions, summarized PRP investigations and investigations within the Wellfields, evaluated the fate and transport and nature and extent of cVOCs affecting the Wellfields, and summarized risk to human health and the environment. The HHERA concluded there is no reasonable potential for adverse effects to human health or the environment associated with the operation of the Wellfields or the water supplied by Citizens. The FS evaluated available remedial technologies to address impacts to the Wellfields in the future, if necessary. These reports, and other documents, are contained in the Administrative Record file for this Site. Additionally, IDEM developed a Proposed Remedial Action Plan (RAP), which identified aeration as the preferred remedial alternative for treatment of production wells if needed in the future, and the accompanying Record of Decision (ROD).

Record of Decision

Based upon the applicable or relevant and appropriate requirements (ARARs) evaluation performed for the Feasibility Study (FS), and the requirements outlined in the MOA, U.S. EPA MCLs were selected as the Remediation Goals for the cVOC treatment of groundwater from the production wells in the Wellfields.

On September 28, 2021 IDEM signed a Record of Decision (ROD) documenting the remedial action for production wells where raw water exceeds MCLs. Since the focus for the Site is to continue to provide a safe source of drinking water from the production wells for public consumption, the following Remedial Action Objectives (RAOs) have been developed to accomplish this goal:

- Prevent commercial/industrial worker direct contact scenarios and inhalation exposure to groundwater produced from the production wells within the Wellfields with cVOC concentrations in excess of state or federal standards.
- Treat the groundwater (if needed) produced from production wells within the Wellfields containing cVOC concentrations in excess of a MCL to remove cVOCs to concentrations that are protective of human health and that are below MCLs prior to mixing with surface water, subsequent treatment, and distribution for public consumption.
- Provide a long-term monitoring and response action plan capable of continuing to provide a constant supply of safe drinking water for the public.

The Selected Remedy described in the ROD for Site 0153 includes:

- Remove from service any production well where raw groundwater cVOC concentrations exceed an MCL¹ and either:
 - Remain out of service until a minimum of two consecutive resampling events, completed on separate occasions, demonstrate that production well results are reliably and consistently below MCLs; or
 - Install treatment (i.e., aeration²) equipment to reduce concentrations and complete confirmatory sampling of post-treatment water to ensure results are below MCLs before returning the well to service.
- Continue operation and maintenance of the aeration equipment installed for production well WR-3 (or any other well that requires it) until aeration is no longer necessary, to ensure all raw groundwater in active production wells is below MCLs.
- Continue routine quarterly sampling³ of active production wells for cVOCs until monitoring has demonstrated that raw groundwater is below MCLs.

In addition to the elements of the Selected Remedy detailed above, additional measures outside the Selected Remedy that will be undertaken to further ensure protection of human health and the environment, which were described in the January 19, 2021 Remedial Action Plan (RAP), include the following:

- IDEM has entered into settlements with willing Site 0153 PRPs to create a settlement fund entitled “Site 0153 Monitoring and Future Response Fund (MAFR).” For the first five years, all settlement payments will be dedicated to funding future response actions within Site 0153, including:

¹ Exceedances of an MCL will be determined through quarterly sampling conducted by Citizens. An MCL exceedance will be determined by calculating a running annual average of all samples taken from an individual production well. If any sample result would cause the running annual average to exceed the MCL, the production well would be considered above the MCL. The MCL exceedance criteria is adapted from 327 Indiana Administrative Code (IAC) 8-2-5.5 (15)(A) and (C).

² IDEM will follow the EPA’s policy of encouraging appropriate remedy changes in response to advances in remediation science and technology in the implementation of this ROD. If new information is received by IDEM after the ROD is signed that could affect the implementation of the selected remedial technology, or could prompt the reassessment of that remedy, IDEM will consider and respond to that new information and place such comments and responses in the Site record. If IDEM determines a change in remedy is warranted, IDEM will document the change appropriately in the Site record.

³ If future quarterly sampling events consistently demonstrate cVOC concentrations in the Wellfields are below MCLs, even before standard mixing and treatment operations, sampling frequency could be reduced.

- Monitoring related to protecting Citizens production wells from cVOCs;
 - Collecting new evidence to determine whether cVOCs released from any PRP's facility threaten or impact any production wells in use within the Wellfields;
 - Funding or installing suitable water treatment equipment to remove cVOCs from water extracted from Citizens' production wells; and
 - If both remediation and treatment are not cost effective, funding the relocation of production wells as necessary to maintain use of the Wellfields or development of a new wellfield.
- As specified in the Agreed Order executed by IDEM and Site 0153 PRPs on March 11, 2021, if the MAFR Fund is not needed for these purposes, IDEM may begin spending the fund on IDEM oversight costs beginning on January 1, 2026. IDEM will continue to work closely with the public, community organizations, governmental entities (including the City of Indianapolis and the Marion County Public Health Department (MCPHD)), and other stakeholders to ensure their involvement in both the Selected Remedy and the progress of any discrete PRP site remediation and/or monitoring program within Site 0153.
 - IDEM and the MCPHD will continue to ensure that any private wells within Site 0153 meet MCLs including sampling the wells if requested by the property owner.
 - IDEM will provide annual reports to the U.S. EPA detailing IDEM's progress in regard to the investigation and remediation of PRP sites within the immediate or surrounding areas of the wellfields, the quality of the drinking water supplied to customers from the Wellfields, and community participation in the Site. In addition, IDEM will continue to maintain and update the website for Site 0153 at: www.idem.IN.gov/Site0153 until the formal de- proposal of Site 0153 from inclusion on the National Priorities List (NPL) is finalized.
 - Citizens will provide IDEM with routine updates regarding quarterly sampling results and annual rolling cVOC averages for operating production wells within the Wellfields. Routine updates will continue for a period of 5 years from the date the ROD was finalized (September 28, 2026) or until IDEM and Citizens agree that updates are no longer necessary (whichever is sooner).

Since the aeration treatment includes elements to prevent cVOC-impacted groundwater captured by the Wellfields from entering the Citizens mixing and pre-treatment plant prior to mixing, treatment, and distribution, the aeration treatment will allow for unlimited use of the groundwater in the Wellfields, providing a long-term solution capable of continuing to provide a constant supply of safe drinking water to the public. Furthermore, IDEM can rely on Citizens' operations, and under their Drinking Water permit with IDEM, to ensure that water supply remains safe for public use.

Additionally, IDEM will continue to work with and pursue PRPs under state remediation programs to investigate and remediate the various discrete and disparate sources of cVOC impacts within the 5-year time of travel of the Wellfields. IDEM's continued efforts under

state remediation programs will ensure the cVOC impacts within the Site continue to diminish while aeration treatment provides protection of risks at the Wellfields and groundwater production wells now and into the future.

Remedial Design

Aeration treatment is a treatment technology commonly used for the removal of VOCs, including cVOCs, from water. This method involves moving air through the contaminated water to volatilize and remove VOC contaminants from the water and transfer them to the air. Following aeration, the vapors are either collected and additionally treated or vented directly to the atmosphere, if contaminant concentrations are acceptable for discharge. The ability for aeration treatment to remove cVOCs from water is dependent upon the vapor pressure and solubility of the contaminants. The cVOCs seen in the groundwater at the Wellfields are all amenable to aeration and can be successfully removed from the water at the dissolved concentrations observed to date.

Several forms of aeration technology exist including aerators (also known as bubble diffusion), packed-tower air strippers, and tray-type air strippers. Each aeration technology uses the same principal of forcing air through water to volatilize contaminants. Ultimately, the selected aeration equipment is based upon the flow requirements for treatment, with larger flow applications using aerators and packed-tower air strippers and lower flows using tray-type air strippers.

Aeration has been shown to be effective in removing dissolved chlorinated solvents from groundwater. In addition, contaminated water is contained during treatment, minimizing the chance for human exposure to untreated, raw groundwater. A packed-tower air stripper unit was installed on production well WR-3 as an interim remedy, and has been shown to be effective at reducing the cVOC concentrations in the extracted raw groundwater.

II. REMEDIAL CONSTRUCTION ACTIVITIES

The White River production well, WR-3, was shut down in 2016 due to TCE concentrations above the MCL. Citizens worked with American Structure Point Inc, Bowen Engineering Corporation, and WesTech to design an aerator to treat production well WR-3 raw groundwater as a pre-emptive remedy to reduce cVOC concentrations in the extracted raw groundwater. Aeration design requirements were based upon WR-3 TCE concentrations and flowrate requirements. The selected aerator for installation was a WesTech Model AWF310 Aluminum Forced Draft Aerator packed with LANPAC-XL® packing. The aerator was designed to treat a flowrate of 1,300 gallons per minute. The aerator was built in 2019 by WesTech at their Ames, Iowa facility. The aerator was shipped to the Wellfield and was field assembled by Bowen Engineering Corporation beginning in September 2019. Electrical power, as well as other ancillary equipment (i.e., pipe supports, connection piping, valving, etc.), were connected from a nearby area to complete the installation. Construction of the

aerator was completed in late January 2020. The aerator is protected by security fencing provided at the Wellfield. Major components and operating parameters of the aerator system include:

- Forced Draft Aerator in Aluminum Housing (Dimensions: 96" Wide X 96" Long X 120" High without legs);
- Aluminum Distributor Box with air stacks and nozzles;
- LANPAC-XL size 3.5" internal packing;
- Air Exhaust with standard #24 mesh hood and moisture separator;
- Peerless-Winsmith, Inc. Model B-182 belt driven blower producing 4,800 cubic feet per minute (cfm) of air at 3/8" of static pressure.
- Blower motor is 2 horsepower (hp), 3 phase, 60 Hertz, totally-enclosed fan cooled (TEFC).
- Motor starter;
- Standard blower screened air inlet hood; and,
- Standard aluminum to aerator transition.

Refer to **Appendix A** for as-built diagrams as well as specification details for the aerator, blower, and packing. Citizens conducted testing efforts on WR-3 from February through April 2020 prior to returning the production well to service; the sampling procedures to ensure proper operation of the system are outlined below.

Production well groundwater sampling is conducted quarterly by Citizens Water employees trained in the collection of VOC samples. Prior to sampling, if a well is not in operation, it is turned on and pumped for at least 24 hours. Each well is fitted with a petcock, which allows for diversion of water flow in the production well for sample collection. Samples are collected by purging the stagnant water within the petcock fittings, reducing the flow to approximately the width of a pencil, and slowly filling the laboratory-provided sample bottles by tilting sideways to prevent aeration. Once field-preserved with hydrochloric acid and evaluated for headspace, the samples are placed on ice before submission to the laboratory. Sample analysis is conducted at the Citizens Energy Group laboratory, which is an Indiana certified drinking water chemistry laboratory. Production well WR-3 is currently back in service with aeration treatment in place. Both *pre*- and *post*-aeration groundwater sampling is conducted to ensure that the aeration system is operating correctly. All *pre*- and *post*-aeration WR-3 groundwater is below MCLs as shown in **Table 1** below.

The aeration system was installed as an interim remedy was used to initiate cleanup at the Site. The interim remedy was effective at treating the raw groundwater at WR-3 and meeting the site remediation goals, and no further response actions are necessary at the Wellfields at this time. A final ROD was issued on September 28, 2021 and the site qualified as construction completed in September 2021, upon issuance of the final ROD.

TABLE 1
WR3 cVOC ANALYTICAL RESULTS
PRE- AND POST-AERATION PRODUCTION WATER

Contaminants of Concern:			Trichloroethene	1,1,1-Trichloroethane	cis-1,2-Dichloroethene	1,1-Dichloroethane
USEPA Maximum Contaminant Level			5	200	70	NE
Sample Location	Date Collected	Sample ID	µg/L	µg/L	µg/L	µg/L
WR3	02/11/2020	Pre	2.35	0.28 J	<0.177	<0.129
	02/20/2020	Pre	2.25	0.23 J	0.19 J	<0.129
		Post	1.12	<0.11	<0.177	<0.129
	03/02/2020	Pre	3.36	0.47 J	0.77	0.18 J
		Post	1.73	0.26 J	0.55	<0.129
	03/11/2020	Pre	3.75	0.38 J	0.99	0.26 J
		Post	1.99	0.18 J	0.70	0.13 J
	03/17/2020	Pre	4.01	0.40 J	1.19	0.32 J
		Post	2.28	0.19 J	0.85	0.18 J
	04/07/2020	Pre	3.40	0.42 J	1.02	0.34 J
		Post	1.88	0.21 J	0.81	0.23 J
	04/15/2020	Pre	3.89	0.42 J	1.32	0.38 J
		Post	2.12	0.22 J	0.98	0.25 J
	04/22/2020	Pre	4.10	0.43 J	1.47	0.43 J
		Post	2.48	0.23 J	1.00	0.26 J
	04/28/2020	Pre	3.91	0.43 J	1.24	0.38 J
		Post	2.37	0.24 J	0.95	0.25 J
	05/13/2020	Pre	3.60	0.40 J	1.46	0.39 J
		Post	2.05	0.19 J	1.01	0.26 J
	05/27/2020	Pre	3.13	0.43 J	1.22	0.41 J
		Post	1.02	0.18 J	0.59	0.15 J
	06/10/2020	Pre	4.04	0.42 J	1.44	0.54
		Post	0.85	<0.11	0.52	0.19 J
	06/25/2020	Pre	3.95	0.53	<0.177	<0.129
		Post	1.01	<0.11	<0.177	<0.129
	07/08/2020	Pre	4.06	<0.11	1.16	0.50
		Post	0.90	<0.11	<0.177	<0.129
	07/22/2020	Pre	4.20	0.60	1.00	0.50
		Post	1.00	<0.11	<0.177	<0.129
	08/05/2020	Pre	4.20	<0.11	1.20	<0.129
		Post	1.00	<0.11	<0.177	<0.129
	08/19/2020	Pre	3.73	0.45 J	1.27	0.34 J
		Post	1.15	<0.11	0.54	<0.129
	09/14/2020	Pre	4.10	0.51	1.69	0.46 J
		Post	1.01	0.13 J	0.49 J	<0.129
	10/05/2020	Pre	3.92	0.52	1.51	0.49 J
		Post	1.26	<0.11	0.57	<0.129
	01/20/2021	Pre	5.56 ^	0.47 J	1.34	0.47 J
		Post	1.85	<0.11	0.65	0.20 J
	02/03/2021	Pre	4.95	0.63	1.67	0.60
		Post	1.48	0.14 J	0.67	0.19 J
	03/04/2021	Pre	5.95 ^	0.55	2.11	0.68
		Post	1.56	0.13 J	0.68	0.16 J
	05/05/2021	Pre	4.55	0.47 J	1.50	0.48 J
		Post	1.30	<0.11	0.60	0.17 J
	06/02/2021	Pre	4.26	0.54	1.42	0.46 J
		Post	1.16	0.12 J	0.59	0.17 J
	07/13/2021	Pre	4.77	0.64	1.54	0.54
Post		1.29	0.12 J	0.61	0.17 J	
08/09/2021	Pre	4.80	0.56	1.46	0.41 J	
	Post	1.30	<0.11	0.45 J	<0.129	

III. CHRONOLOGY OF EVENTS

Date	Event
February 20, 2013	Citizens Water notice to IDEM of cVOC Detections in Raw Water
June 18, 2013	IDEM, Citizens Water, and US EPA Conduct Site Inspection
November 1, 2013	IDEM issues a Preliminary Assessment Report
October 23, 2014	IDEM issues a Site Inspection Report
August 13, 2015	IDEM Commissioner Requests Inclusion of Site 0153 on the NPL via letter
April 1, 2016	US EPA published Proposed Rule to Include Site 0153 to NPL
August 18, 2016	IDEM Commissioner Rescinds NPL Request Based on New Information and Proposes Alternative Plan
September 2016	Production Well WR-3 is shutdown
January 2017	Citizens Increases Sampling to Quarterly
January 2017-2020	IDEM issues Request for Information and Notice of Liability Letters to Potential Responsible Parties
June 8, 2017	Memorandum of Agreement between U.S. EPA and IDEM is Executed
September 2019	Installation of interim remedy Aeration System on WR-3
January 2020	Completion of Aeration System on WR-3
February through April 2020	Aeration System Testing ⁴
April 2020	Confirmation sampling shows effective operation of the aeration system, Production Well WR-3 back in service
November 10, 2020 through December 11, 2020	RI, HHERA, and FS available for Public Comment
November 18, 2020	Public Meeting Conducted
January 19, 2021 through February 18, 2021	Proposed RAP and ROD available for Public Comment
September 28, 2021	Record of Decision Signed
September 28, 2021	Construction Completion of the remedy after issuance of the ROD
Ongoing	Quarterly Monitoring of Production Wells

IV. PERFORMANCE STANDARDS AND CONSTRUCTION QUALITY CONTROL

Concentrations of TCE in production well WR-3 ranged from 4.43 to 8.18 micrograms per liter ($\mu\text{g/L}$) prior to being shut down in September 2016. As an interim remedy,

⁴ Citizens followed vendor requirements during startup and testing of the aerator system.

Citizens engineered and installed an aeration system for production well WR-3 beginning in September 2019. The performance standard for the aeration system was to reduce the concentrations of cVOCs below the MCL (as listed above in **Table 1**). Aeration system construction was completed in late January 2020. Citizens conducted aeration testing on production well WR-3 from February through April 2020 and brought the well back into service in April 2020.

Currently cVOC concentrations in all raw water generated from production well WR-3, even before it is aerated, are below the MCL. CVOC concentrations in all other production wells have remained below MCLs. Remediation Goals have been achieved at the Site and Citizens has committed to continued monitoring and removal from service and/or installation of aeration equipment on any production wells if future cVOC concentrations exceed an MCL. Results of the *pre*- and *post*- aeration raw water indicates that the Remedial Action successfully reduces cVOC concentrations at the production well even before being mixed with other groundwater/surface water prior to treatment and distribution (see Table 1, next page). Citizens has treated a total of approximately 497 million gallons of raw groundwater from WR-3 since the installation of aeration.

All raw groundwater and finished water sampling data associated with the Wellfields are collected and analyzed by Citizens. Citizens operates an internal drinking water chemistry laboratory certified by the Indiana State Department of Health for both chemical and microbiological analyses. Samples are collected and analyzed for VOCs in accordance with U.S. EPA Method 524.2, which details the measurement of organic compounds for analysis of drinking water. Standard quality assurance/quality control (QA/QC) protocols as required by Citizens' approved laboratory certification are followed throughout the sampling and analysis process, documenting acceptance criteria for custody, preservation, instrument calibration, quantification, and QA/QC sample performance standards (e.g., blanks, spikes, and duplicates). The QA/QC program ensures that reported analytical results are accurate and adequate to ensure satisfactory execution of the remedial action, in a manner consistent with the requirements of the ROD.

V. FINAL INSPECTION AND CERTIFICATIONS

Inspections

Observations, inspections, and testing during operation of the aeration treatment process found no significant operation issues affecting the performance of the Remedial Action. Since the installation of aeration treatment, all *post*-aeration WR-3 raw groundwater is below MCLs. Additionally, all *pre*-aeration WR-3 raw groundwater water is currently below the MCL. A contingency plan is in place if any other production wells have detections over screening levels in the raw water in the future.

Citizens performs inspection and Operations and Maintenance (O&M) on the system in accordance with vendor recommendations or more often as needed to keep the aerator system in peak operating condition. A copy of the vendor O&M plan is included as

Appendix B.

In addition to inspections and O&M, Citizens performs raw groundwater sampling on a quarterly basis for a period of five (5) years or until IDEM and Citizens agree that increased sampling is no longer needed. After this period the raw groundwater sampling will revert to semi-annual sampling. This sampling will show the aerator system continues to treat the cVOCs to concentrations below MCLs.

Health and Safety

No health and safety issues were encountered during installation or since the start of operations for the aeration treatment. Although, the liberated cVOCs will be discharged to the atmosphere, the treatment will be performed in accordance with an air discharge permit (if required) to meet acceptable limits. Citizens' written *Employee Safety Manual* will be used in reference when performing O&M on the aeration system. A copy of the Employee Safety Manual is included as **Appendix C**. The finished drinking water has always met, and continues to meet the requirements of the SDWA.

Certification of Completion of State Response Action

The groundwater extracted from the Wellfield achieve the Remediation Goals. The pre-emptive remedy has proven to be effective at reducing the cVOCs concentrations in WR-3. The remedy is performing as intended and quarterly monitoring will continue at the production wells to ensure that remediation goals continue to be met.

IDEM considers the response action at the Site to be complete, and certifies that the Selected Remedy has been successfully completed and the intended cleanup levels have been achieved.

VI. OPERATION AND MAINTENANCE ACTIVITIES

In 2017, Citizens developed and implemented a Groundwater Monitoring Plan with an increased sampling of production wells from semi-annually to quarterly to monitor cVOC concentrations in the Wellfields. This sampling frequency will continue, with reporting to IDEM, for a period of 5 years or until IDEM and Citizens agree that updates are no longer necessary. In addition, operation and maintenance of the aeration treatment equipment installed for production well WR-3 (or any other well that requires it) will continue until aeration treatment is no longer necessary, to ensure all raw groundwater in the production wells remains below MCLs. Routine aerator system inspections and O&M are performed as recommended by the equipment vendor and generally includes:

- Inspecting the aerator and blower housings for integrity;
- Inspecting bearings, belts, and motors and replacing parts as needed;
- Lubricating applicable components;
- Checking the motor for vibrations and rebalancing as needed;
- Removal of insects, leaves, and other foreign particles from the system screens on an as

needed basis.

- Inspecting and replacing air exhaust hood and inlet hood components as required; and,
- Inspecting the LANPAK-XL internal packing on a yearly basis and replacing or cleaning when severe fouling occurs.

In addition to the aeration system, individual PRP sites will continue to be investigated and remediated under IDEM’s State Cleanup Program. No land use restrictions or institutional controls are necessary for the wellfields and are therefore not a part of the Selected Remedy. Citizens will be the implementing entity, responsible for implementing the steps outlined above if they become necessary, and/or until they are no longer necessary. Furthermore, IDEM can rely on Citizens’ operations, and under Citizens’ Groundwater Monitoring Plan, to ensure that water supply remains safe for public use. Institutional controls have been placed on a total of 72 properties within the Site 0153 general boundary to address various contaminants and exposure pathways, listed in **Appendix D**. Groundwater use restrictions via Environmental Restrictive Covenants (ERCs) are anticipated to be utilized at several of the individual sites within the Site 0153 area, following completion of remediation efforts and prior to closure of the individual sites.

VII. SUMMARY OF AERATION TREATMENT COSTS

Table 2 summarizes the costs associated with aeration treatment. The estimated present-worth costs of using aeration for treatment of the wellfields is \$1,894,000. The aeration equipment and operating costing is based on actual costs for the aeration system installed on production well WR-3. The removal efficiency for production well WR-3 is currently 50-60%. The O&M costs for the aeration system assumes the system will be routinely washed and the packing will be replaced with new material, as needed, for a period of 30 years. Electricity costs to operate the aeration blower for the system were also accounted for.

Table 2. Summary of Aeration Treatment Costs	
Activity	Cost
Design/Treatability Testing/Post-Installation Testing	\$50,000
Capital Cost	
Equipment	\$650,000
Installation (30%) of Equipment Cost)	\$195,000
Building Upgrades	\$25,000
Electrical Service Installation	\$10,000
Subtotal	\$880,000
Operation & Maintenance (30 years)	
Electricity Cost	\$454,000
Media Wash with Labor	\$360,000
Media Replacement with Labor	\$150,000
Subtotal	\$964,000
Total	\$1,894,000

VIII. CONTACT INFORMATION

Indiana Department of Environmental Management
Office of Land Quality
State Cleanup Section, Attn: Ryan Groves
100 North Senate Avenue, IGCN, Room 1101
rgroves@idem.in.gov
(317) 232-3413

Katherine Thomas, Remedial Project Manager
United States Environmental Protection Agency, Region 5
Superfund and Emergency Management Division
77 West Jackson Blvd., SR-6J
Chicago, IL 60604
Thomas.katherine@epa.gov
(312) 353-5878

APPENDICES

Appendix A: As-Built Diagrams and Specification Details for Aerator, Blower & Packing

Appendix B: Operations and Maintenance Plan

Appendix C: Employee Safety Manual

Appendix D: Institutional Controls Within Site 0153 General Boundary

APPENDIX A
As-Built Diagrams and Specification Details for Aerator, Blower & Packing

CITIZENS ENERGY GROUP
 2150 DR. MARTIN LUTHER KING JR. DRIVE
 INDIANAPOLIS, INDIANA 46202
 WWW.INDIANAPOLISWATER.COM
 (317) 639-1501



RECEIVED BY:

PROJECT MANAGER _____ DATE _____

CITIZENS PROJECT CONTACT INFORMATION

Project Manager: David Williams
 dwilliams@citizensenergygroup.com

CEG PROJECT # 20W02557 WHITE RIVER WELL #3 VOC REMOVAL

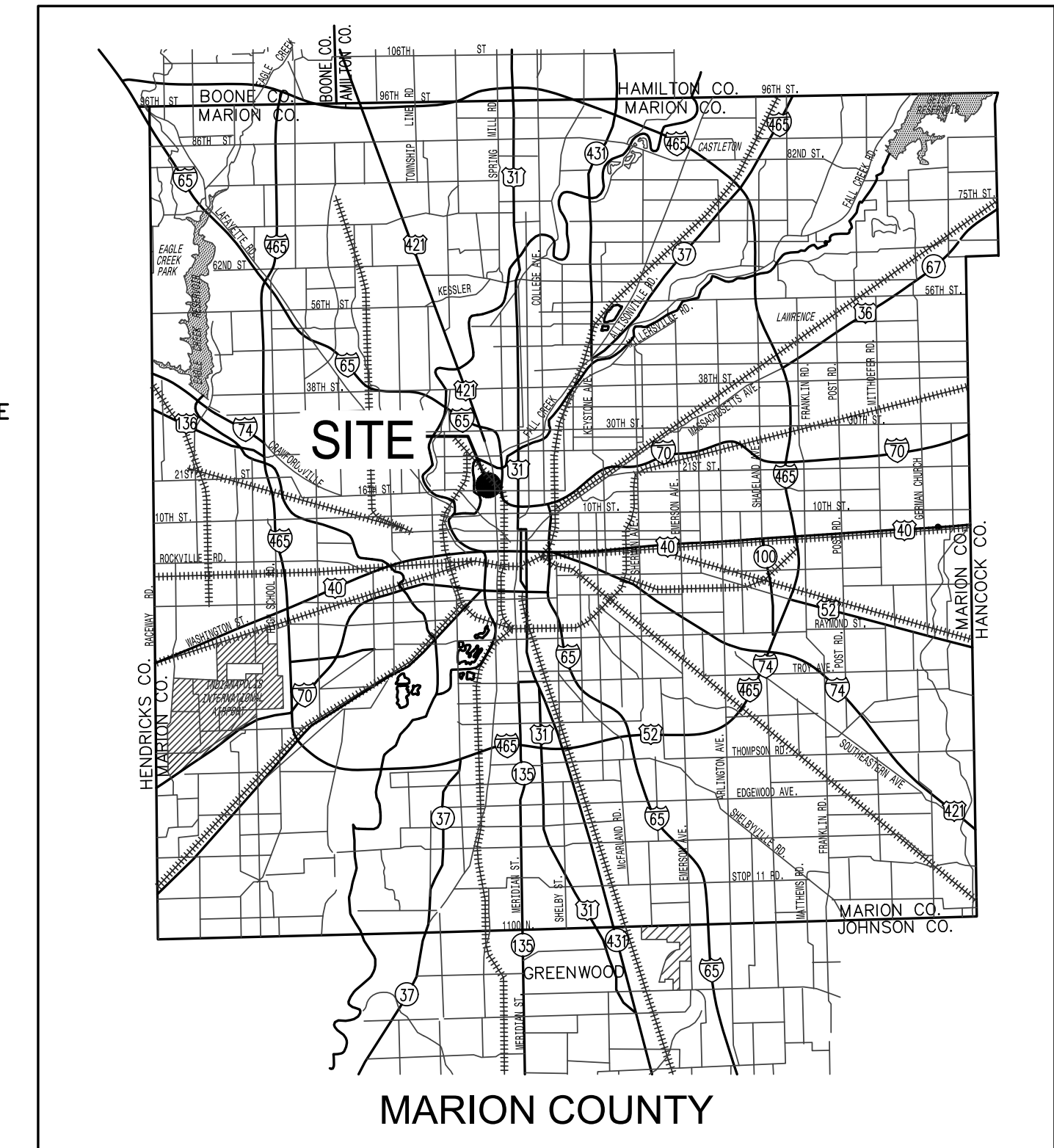
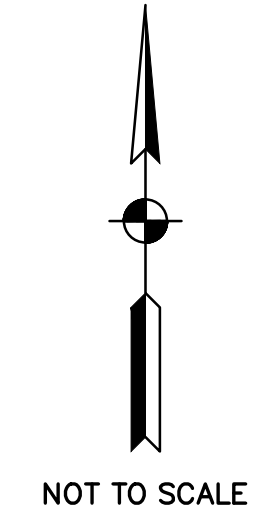

AMERICAN
STRUCTUREPOINT
 INC.

7260 SHADELAND STATION
 INDIANAPOLIS, IN 46256-3957
 TEL 317.547.5580 FAX 317.543.0270

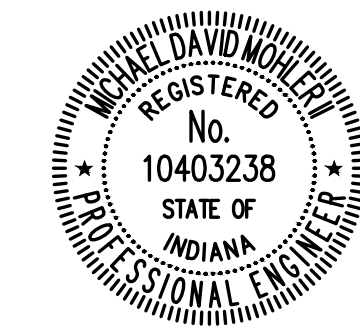

Michael David Mohler II 05/31/2019
 MICHAEL DAVID MOHLER II
 PROFESSIONAL ENGINEER PE NO. 10403238
 STATE OF INDIANA

PROJECT LOCATION

NOT TO SCALE

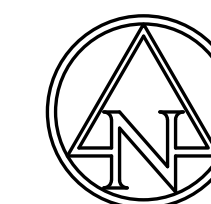

PROJECT N : 2018.00344

WHITE RIVER WELL #3 VOC REMOVAL				SHEET N : G-1
D	Pr	F	T	DATE: 05/31/2019

PLOT SCALE: 1:1 EDIT DATE: 6/7/2019 3:17 PM EDITED BY: jgiffins PA: N/A: 2018.00344.dwg drawing's version number: 201800344.dwg

THE DEPARTMENT OF PUBLIC UTILITIES FOR THE CITY OF INDIANAPOLIS, ACTING BY AND THROUGH THE BOARD OF DIRECTORS FOR UTILITIES, AS TRUSTEE, IN FURTHERANCE OF THE PUBLIC CHARITABLE TRUST FOR THE WATER SYSTEM
INSTR. NO. A201100086305
PARCEL I OF TRACT X

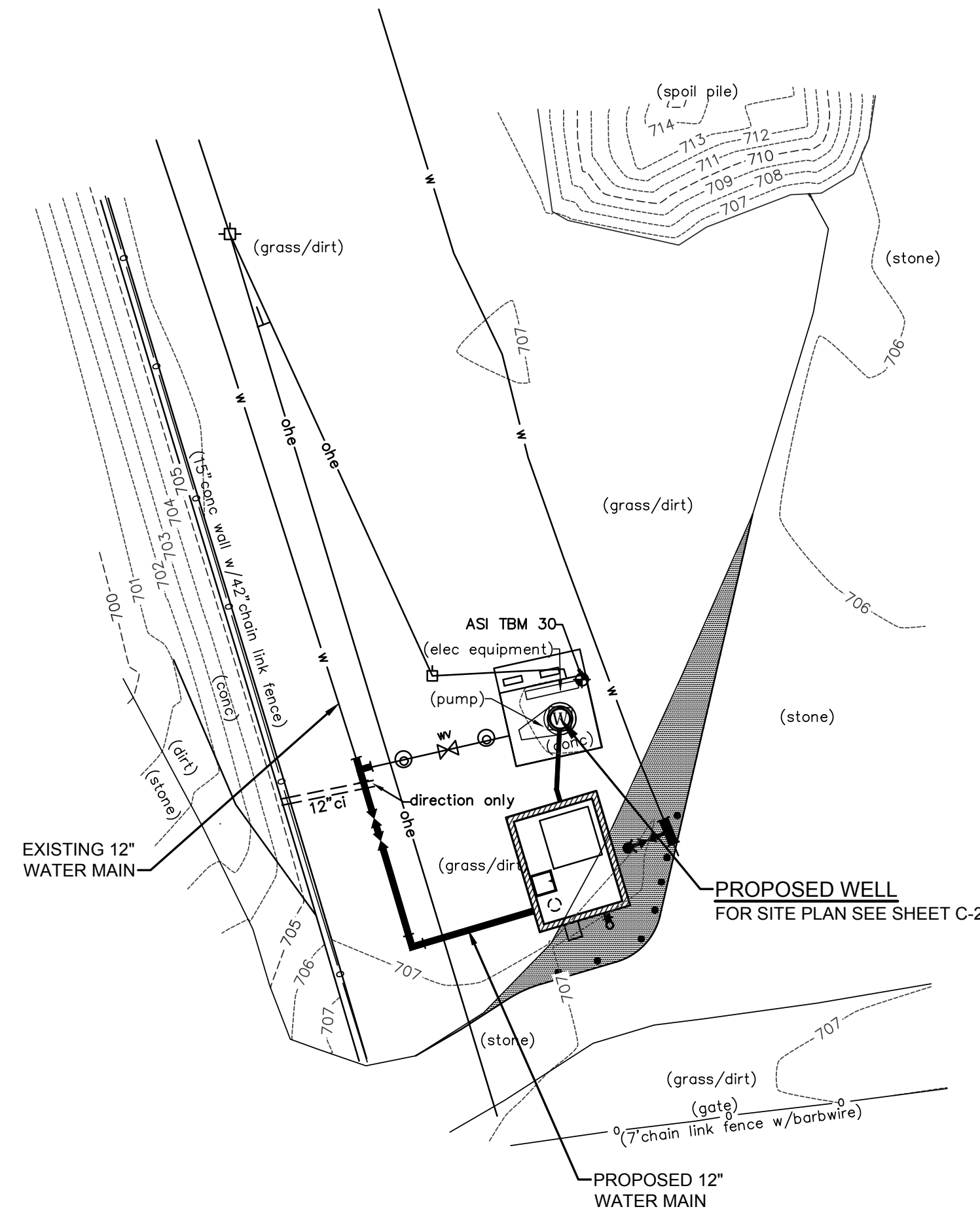

STADIANA, INC.
INSTR. NO. 66-39897



NATIONAL COLLEGIATE ATHLETIC ASSOCIATION
INSTR. NO. 2000-0000515

LEGEND:

- ⊕ COMBINATION POLE
- GUY WIRE
- ⊙ WATER MANHOLE
- ⊠ POWER POLE
- ⊗ WATER VALVE BURIED
- ELECTRIC LINE
- ⊠ OVERHEAD ELECTRIC LINE
- BURIED WATER LINE

BENCH INFORMATION:

(NAVD 1988)

VERTICAL CONTROL WAS BASED ON OPUS SOLUTION 1524709123053 AT POINT #300. CHECKED AGAINST TBM #61 FROM JOB#201502434.

ASI TBM #61
CHISELED "X" ON S BONNET BOLT OF FIRE HYDRANT AT NW CORNER OF THE INTERSECTION OF 16TH STREET & REMBRANDT STREET; 45' N OF CL 16TH STREET; 30' W OF CL REMBRANDT STREET; 80' NE OF POWER POLE #219463B ON THE N SIDE OF 16TH STREET.
ELEV. = 697.65

ASI TBM #30
CHISELED SQUARE ON NE CORNER OF CONCRETE AT WELL #3.
ELEV. = 707.07

GENERAL NOTES:

1. CAUTION !! - THE LOCATIONS OF ALL EXISTING UNDERGROUND UTILITIES SHOWN ARE BASED UPON ABOVE GROUND EVIDENCE (including, but not limited to, manholes, inlets, valves, and marks made upon the ground by others) AND/OR RECORD DRAWINGS PREPARED BY OTHERS AND ARE SPECULATIVE IN NATURE. THERE MAY ALSO BE OTHER EXISTING UNDERGROUND UTILITIES FOR WHICH THERE IS NO ABOVE GROUND EVIDENCE OR FOR WHICH NO ABOVE GROUND EVIDENCE WAS OBSERVED. THE EXACT LOCATIONS OF SAID EXISTING UNDERGROUND UTILITIES SHALL BE VERIFIED BY THE CONTRACTOR PRIOR TO ANY AND ALL CONSTRUCTION. - CALL TOLL FREE 1(800)382-5544 INDIANA UNDERGROUND. A PRIVATE UTILITY LOCATOR SHALL BE HIRED BY THE CONTRACTOR TO VERIFY LOCATIONS OF ALL UTILITIES WITHIN THE WELLFIELD.
2. NOTIFY THE FOLLOWING PRIOR TO THE BEGINNING OF ANY CONSTRUCTION:
CITIZENS WATER - (317) 639-1501
3. ALL UTILITIES ARE TO BE MAINTAINED IN SERVICE AT ALL TIMES UNLESS PRIOR AUTHORIZATION IS GRANTED FROM THE RESPECTIVE UTILITY FOR A PLANNED SERVICE INTERRUPTION NECESSARY FOR THE COMPLETION OF THIS WORK. UTILITIES AND OBSTRUCTIONS SHOWN ON THE PLANS WERE DERIVED FROM THE BEST AVAILABLE INFORMATION THROUGH CONTACT MADE WITH THE VARIOUS UTILITIES AND AGENCIES KNOWN TO HAVE STRUCTURES IN THE AREA. THE LOCATION, MATERIAL AND DIMENSIONS OF EXISTING OBSTRUCTIONS ARE BASED UPON AVAILABLE RECORDS BUT MUST NOT BE CONSTRUED AS BEING ACCURATE, CORRECT, OR COMPLETE. ALL STRUCTURES ABOVE OR BELOW GROUND ENCOUNTERED DURING CONSTRUCTION SHALL BE PROPERLY SUPPORTED AND MAINTAINED. THE CONTRACTOR SHALL MAKE ARRANGEMENTS WITH THE OWNER OF SUCH STRUCTURES FOR SHIFTING, SUPPORT, TEMPORARY RELOCATION, AND PROTECTION WHERE NECESSARY. IF DAMAGED DURING CONSTRUCTION, THE CONTRACTOR SHALL MAKE OR PAY TO HAVE MADE ALL REPAIRS TO THE STRUCTURE TO THE SATISFACTION OF THE OWNER OF THE STRUCTURE. NO EXTRA PAYMENT WILL BE MADE FOR SUCH REPAIRS.
4. CONSTRUCT THE IMPROVEMENTS ONLY AS SHOWN ON THE PLANS. THE CONTRACTOR SHALL BE RESPONSIBLE FOR ANY AND ALL DAMAGE ON PRIVATE PROPERTY AND SHALL REPAIR SAID DAMAGE AT HIS OWN EXPENSE TO THE SATISFACTION OF THE ENGINEER.
5. SEE SPECIFICATION SECTION 01010 FOR SEQUENCE OF WORK.
6. REPAIR IMMEDIATELY ANY SITE PIPING STILL IN USE CUT OR DAMAGED DURING CONSTRUCTION.
7. PLUG SITE PIPING NO LONGER IN SERVICE, CUT, OR DAMAGED DURING CONSTRUCTION WITH NON-SHRINK GROUT.
8. DISCHARGE WATER SHALL BE CONVEYED OVERLAND FOR MINIMUM 100 FEET BEFORE DISCHARGING INTO WHITE RIVER. DEVELOPMENT DISCHARGE OR PUMP TEST DISCHARGE WATER MAY BE CONVEYED TO WHITE RIVER; HOWEVER, APPROPRIATE EROSION CONTROL MEASURES SHALL BE INSTALLED. ANY PERMITS REQUIRED FOR THIS DISCHARGE TO WHITE RIVER SHALL BE THE RESPONSIBILITY OF THE CONTRACTOR.
9. DISPOSE OF EXCESS EXCAVATION AND CONSTRUCTION DEBRIS IN ACCORDANCE WITH LOCAL, STATE, FEDERAL REGULATIONS, BORE HOLE CUTTINGS AND DRILLINGS MUD.
10. KEEP WORK AREA FREE OF DEBRIS AND OBJECTIONABLE MATERIALS DURING CONSTRUCTION.
11. COORDINATE WITH UTILITY COMPANIES TO HAVE FACILITIES STABILIZED DURING CONSTRUCTION AS NEEDED.
12. WELL DEVELOPMENT OR REHABILITATION FLUIDS SHALL NOT BE DUMPED OR DISCHARGED DIRECTLY OR INDIRECTLY INTO A WETLAND OR OTHER "WATERS OF THE UNITED STATES" OR WATER OF THE STATE OF INDIANA.
13. PRIOR TO ANY SITE EXCAVATION, BURIED UTILITIES MUST BE FIELD LOCATED BY COMPLETION OF VACUUM EXPLORATION TO A MINIMUM DEPTH OF 15-FEET.

DRAWING INDEX

SHEET NO.	DESCRIPTION
GENERAL	
G1.0	TITLE SHEET
SITE, GRADING, AND PLAN AND PROFILES	
C-1	OVERALL SITE PLAN AND GENERAL INFORMATION
C-2	WELL SITE PLAN
C-3	WELL MODIFICATION PLAN AND SECTION
C-4	AERATOR PLAN AND SECTION
C-5	MISCELLANEOUS DETAILS
C-6	EROSION CONTROL DETAILS
STRUCTURAL PLANS	
S-0	STRUCTURAL GENERAL NOTES
S-1	AERATION CHAMBER PLANS
S-2	AERATION CHAMBER SECTIONS AND ELEVATION
S-3	STRUCTURAL TYPICAL DETAILS
S-4	STRUCTURAL TYPICAL DETAILS
S-5	EQUIPMENT PAD DETAILS
ELECTRICAL PLANS	
E-0	SYMBOLS, LEGEND AND GENERAL NOTES
E-1	ELECTRICAL SITE PLAN
E-2	ELECTRICAL DETAILS
E-3	SINGLE LINE DIAGRAM, SCHEMATIC AND PANEL ELEVATION
INTRUMENTATION AND CONTROL PLANS	
I-1	SYSTEM DIAGRAM
I-2	BILL OF MATERIAL
I-3	PLC ENCLOSURE
I-4	PLC BACK PANEL LAYOUT
I-5	120 VAC POWER DISTRIBUTION
I-6	24 VDC DIGITAL POWER DISTRIBUTION
I-7	24 VDC ANALOG POWER DISTRIBUTION
I-8	DIGITAL INPUTS
I-9	DIGITAL INPUTS
I-10	DIGITAL OUTPUTS
I-11	ANALOG INPUTS
I-12	ANALOG OUTPUTS
I-13	BLOWER CONTROL DIAGRAM
I-14	BOOSTER PUMP CONTROL DIAGRAM
I-15	WELL PUMP CONTROL DIAGRAM

UTILITIES

<p>COMMUNICATIONS: AT&T 5858 N. COLLEGE AVE. INDIANAPOLIS, IN 46256 PHONE: 317.252.4007</p> <p>CABLE TV: BRIGHTHOUSE NETWORKS 3030 ROOSEVELT AVE. INDIANAPOLIS, IN 46218 PHONE: 317.632.9077</p> <p>CABLE TV: COMCAST CABLE 8330 E. 65TH STREET INDIANAPOLIS, IN 46220 PHONE: 317.263.6446</p> <p>GAS: CITIZENS ENERGY GROUP 2150 DR. MARTIN LUTHER KING JR. STREET INDIANAPOLIS, IN 46202 PHONE: 317.927.4684</p> <p>ELECTRIC: INDIANAPOLIS POWER & LIGHT 1230 W. MORRIS STREET INDIANAPOLIS, IN 46221 PHONE: 317.261.8617</p>	<p>WATER/SEWER: CITIZENS ENERGY GROUP 2150 DR. MARTIN LUTHER KING JR. STREET INDIANAPOLIS, IN 46202 PHONE: 317.927.4684</p> <p>FIBER OPTIC: FIBER TECHNOLOGIES NETWORK LLC 300 MERIDIAN CENTER ROCHESTER, NY 14618 PHONE: 585.697.5145</p> <p>CODE ENFORCEMENT: INDIANAPOLIS DEPT. OF CODE ENFORCEMENT 1200 MADISON AVE. STE. 100 INDIANAPOLIS, IN PHONE: 317.327.8700</p>
--	---



CAUTION !!

THE LOCATIONS OF ALL EXISTING UNDERGROUND UTILITIES SHOWN ON THIS PLAN ARE BASED UPON ABOVE GROUND EVIDENCE (including, but not limited to, manholes, inlets, valves, and marks made upon the ground by others) AND ARE SPECULATIVE IN NATURE. THERE MAY ALSO BE OTHER EXISTING UNDERGROUND UTILITIES FOR WHICH THERE IS NO ABOVE GROUND EVIDENCE OR FOR WHICH NO ABOVE GROUND EVIDENCE WAS OBSERVED. THE EXACT LOCATIONS OF SAID EXISTING UNDERGROUND UTILITIES SHALL BE VERIFIED BY THE CONTRACTOR PRIOR TO ANY AND ALL CONSTRUCTION.

1-800-382-5544
CALL TOLL FREE

- INDIANA UNDERGROUND -

REVISIONS		
DATE	REVISION	BY

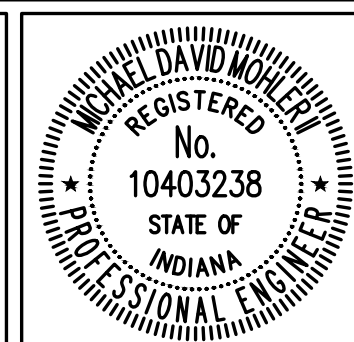

RECOMMENDED FOR APPROVAL	<i>MDM</i>	5/31/2019
DESIGNED:	PAJ	DRAWN:
CHECKED:	MDM	CHECKED:
		PAJ

**WHITE RIVER WELL #3
VOC REMOVAL**

**OVERALL SITE PLAN AND
GENERAL INFORMATION**

CEG PROJECT NUMBER	20WR02557
CONSULTANT PROJECT NUMBER	201800344
SHEET	C-1

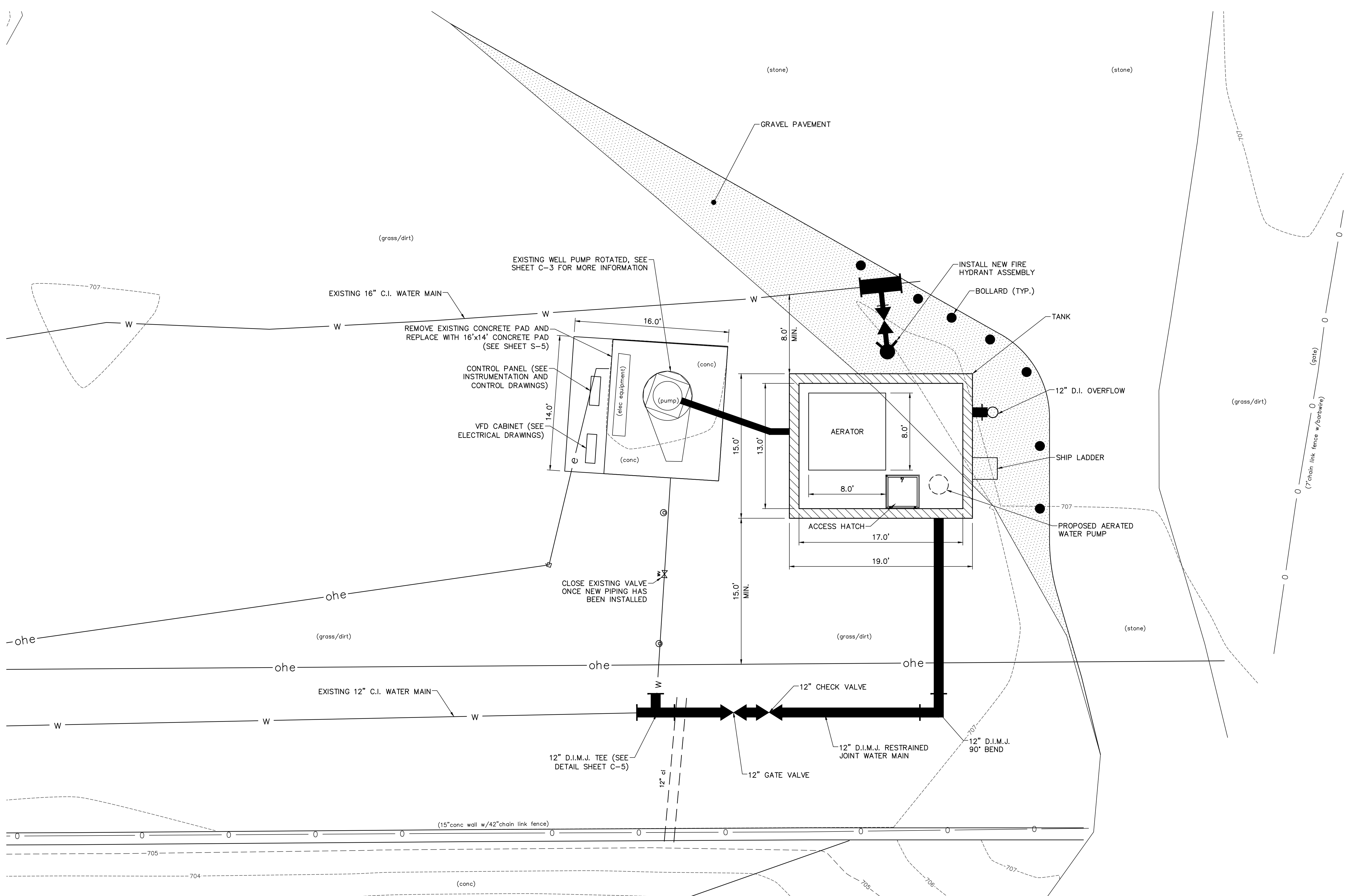
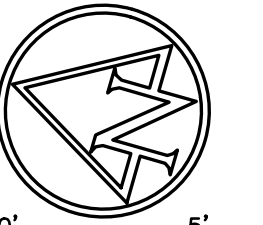

PLOT SCALE: 1"=5' EDT: DATE: 6/7/2019 3:17 PM EDITED: B:\projects\2018\03\34\4\4\drawings\environmental\20180334.ecad.dwg

REVISIONS		
DATE	REVISION	BY

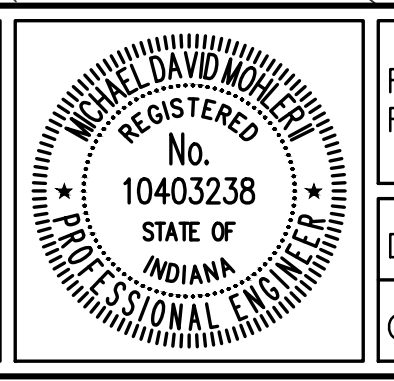
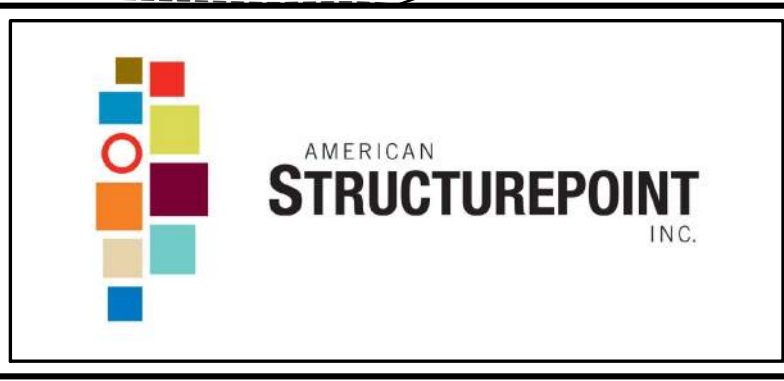

RECOMMENDED FOR APPROVAL	<i>MDM</i>	5/31/2019
DESIGNED: PAJ	DRAWN: MJG	DATE
CHECKED: MDM	CHECKED: PAJ	

WHITE RIVER WELL #3
VOC REMOVAL

SITE PLAN

CEG PROJECT NUMBER	20WR02557
CONSULTANT PROJECT NUMBER	201800344
SHEET	C-2

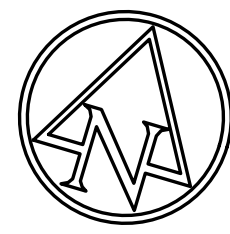
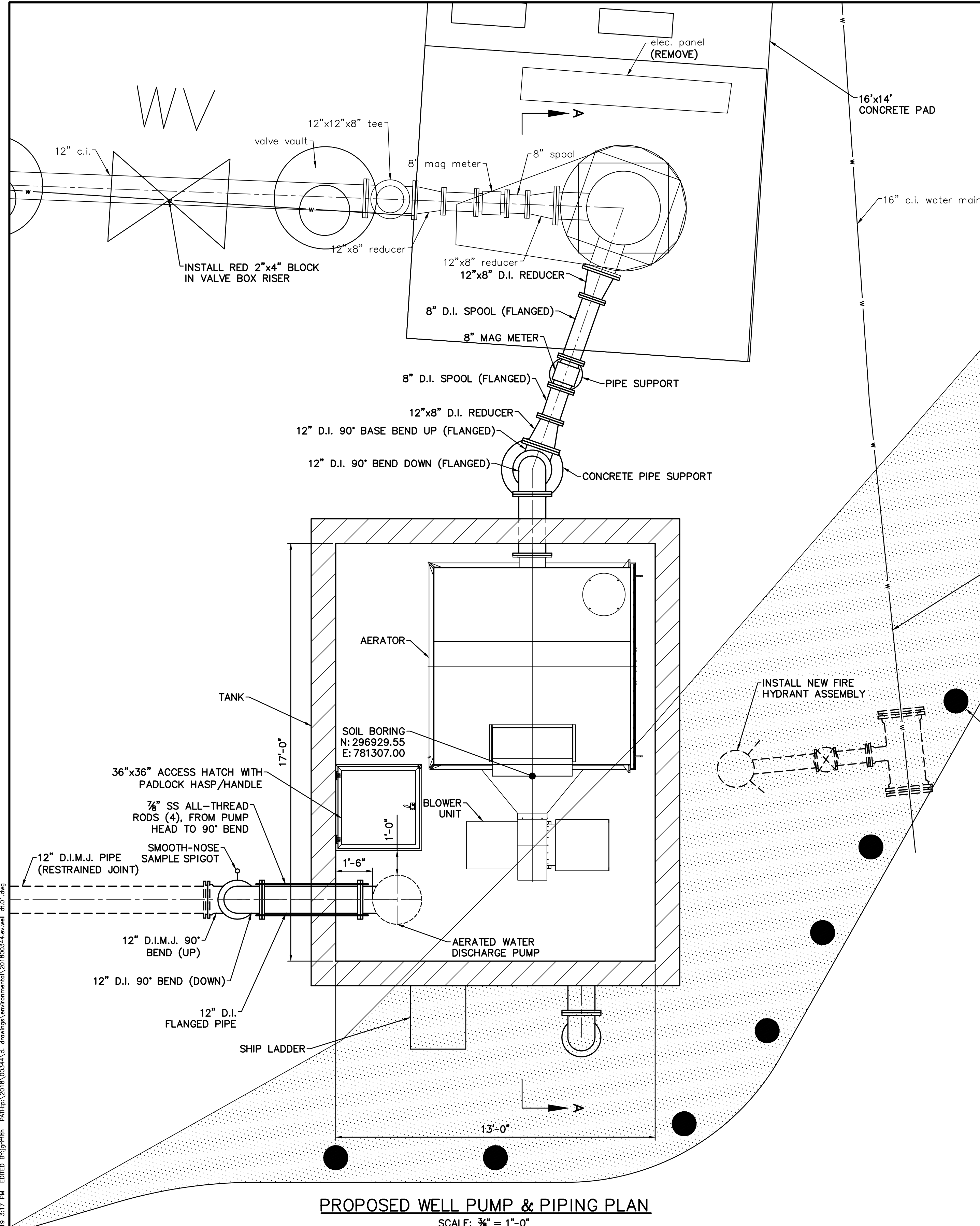

NOTES:

1. SEE ELECTRICAL DRAWINGS FOR MORE SITE DATA AND DETAILS.
2. ROTATE PUMP HEAD TO ALIGN PIPING WITH AERATOR INLET.
3. REMOVE 12" D.I. TEE, INSTALL 12" BLIND FLANGE ON EXISTING DISCHARGE PIPE.
4. INSTALL RED 2"x4" BLOCK IN EXISTING GATE VALVE RISER.
5. INSTALL NEW WELL PUMP AND MOTOR, PER SPECIFICATIONS.
6. DISCHARGE PIPING FROM THE AERATED WATER PUMP SHALL BE INSTALLED WITH HEAT TRACER.

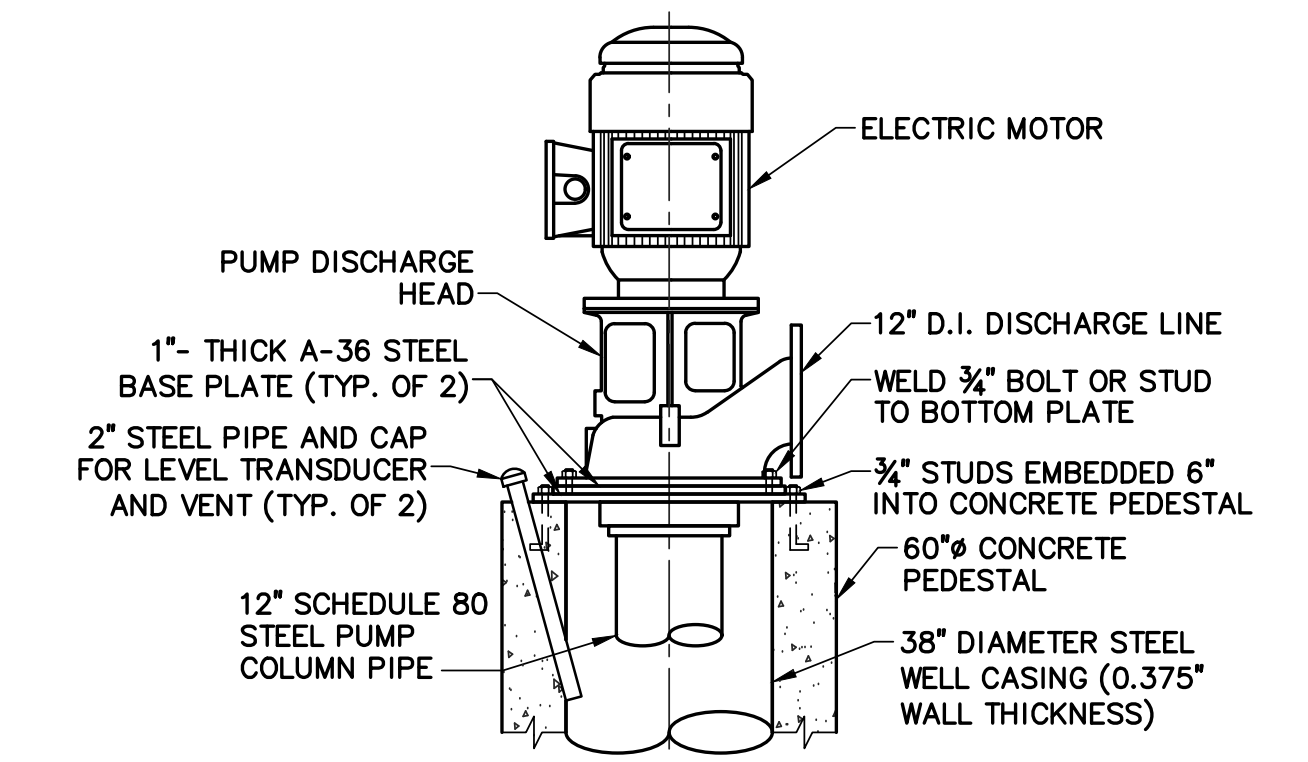

EXISTING PUMP HEAD MOUNTING DETAIL
NOT TO SCALE

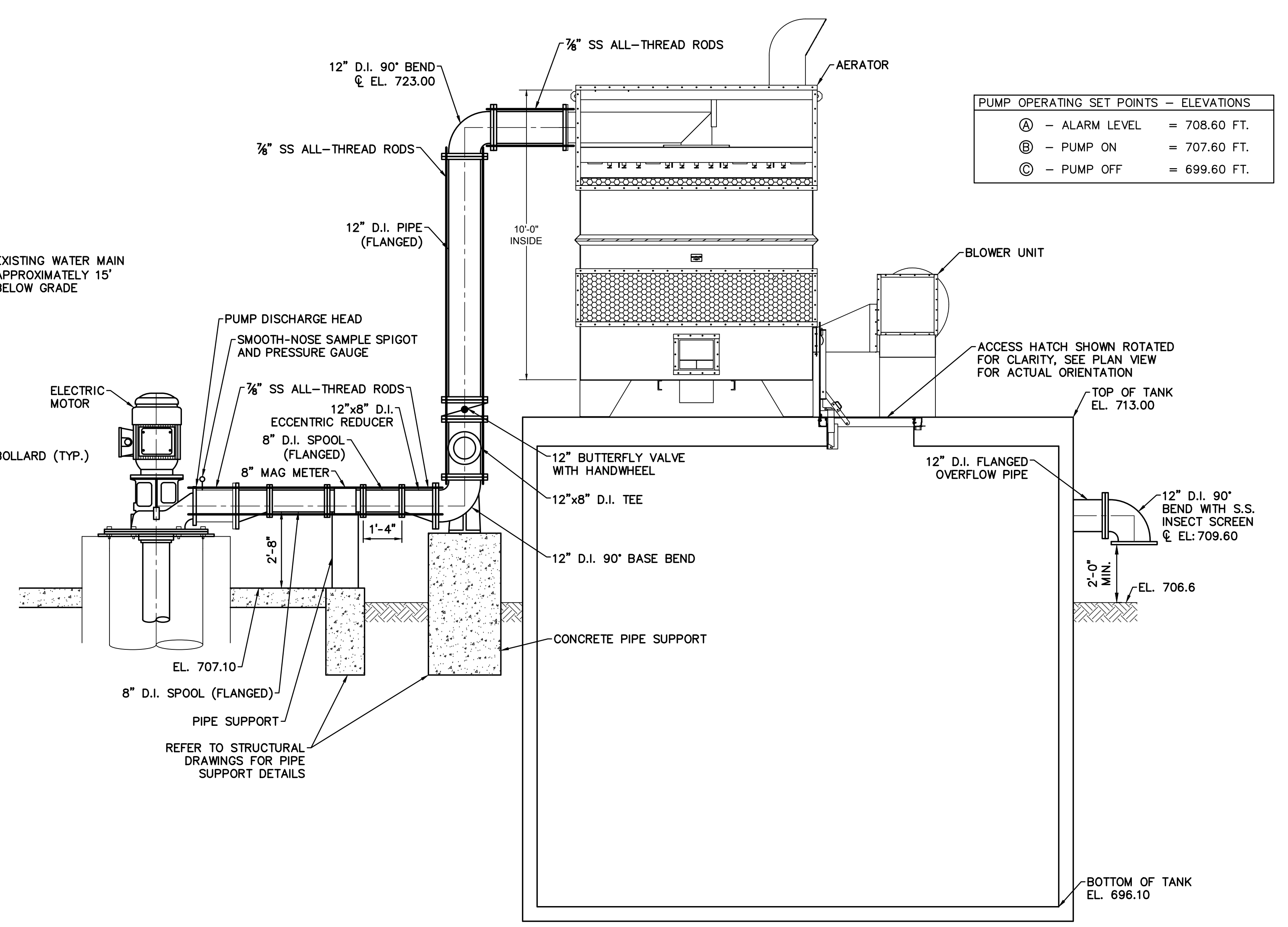

PUMP OPERATING SET POINTS - ELEVATIONS	
Ⓐ - ALARM LEVEL	= 708.60 FT.
Ⓑ - PUMP ON	= 707.60 FT.
Ⓒ - PUMP OFF	= 699.60 FT.

PROPOSED WELL PUMP & PIPING SECTION A-A
SCALE: 3/8" = 1'-0"

PROPOSED WELL PUMP & PIPING PLAN
SCALE: 3/8" = 1'-0"

REVISIONS		
DATE	REVISION	BY

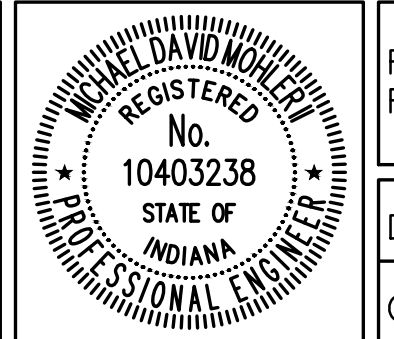

RECOMMENDED FOR APPROVAL	<i>MDM</i>	5/31/2019
DESIGNED:	PAJ	DRAWN:
CHECKED:	MDM	CHECKED:
		PAJ

WHITE RIVER WELL #3
VOC REMOVAL
WELL MODIFICATION
PLAN AND SECTION

CEG PROJECT NUMBER	20WR02557
CONSULTANT PROJECT NUMBER	201800344
SHEET	C-3

PLOT SCALE: 3/8" = 1'-0" DATE: 5/7/2019 3:17 PM EDITED: Bjojgffibh PATH: C:\Users\j... drawings\environmental\201800344.dwg DRAWING: environment\201800344.dwg

BILL OF MATERIAL						
POS	UNIT QTY	ITEM CODE	DESCRIPTION	MATERIAL	LENGTH, IN	TOTAL WT, LB
10	1	W3T157329	SAS AFDA 96SQX10FT LF 1525-1955GPM 4980SCFM			2469.7
20	1	W2T501735	BLWR,HVAC,CENT,BELT DRIVE,#10 ARGT	STL, MILD		310.0
30	1	W2T380013	DUCT,FD BLOWER TRANSITION;182;3003H14AL	AL, 3003		10.0
40	1	W3T63399	HOOD SCREENED EXHAUST 15 IN X 39 IN			25.9
50	1	W3T63516	HOOD SCREENED FD BLOWER INLET 182 3003			18.3
60	50	W2T77539	SCREW,#8 DIA,0.75IN LG,PHLP,SS	STN STL, 18-8		0.2
70	2	W3T62275	CHANNEL TRANS FINISH DRILLED 9 3003	AL, 3003		0.1
80	2	W3T62284	CHANNEL TRANS FINISH DRILLED 52.75 3003	AL, 3003		0.1
90	12	W2T83919	BOLT,HEX;0.25 IN DIA;0.75 IN LG;304SS	STN STL, 18-8		0.2
100	12	W2T84528	NUT,HEX-FIN;0.25 IN DIA;UNC;304SS	STN STL, 18-8		0.1
110	320	W2T436621	PACKNG,PLASTIC;3.5 IN;POLYPROPYLENE	POLYPROPYLENE		896.0
120	3	W2T301959	ADHSV/SEALANT;PERMATEX	SILICONE		6.0

APPROX. OPERATING WEIGHT: 10085 LB

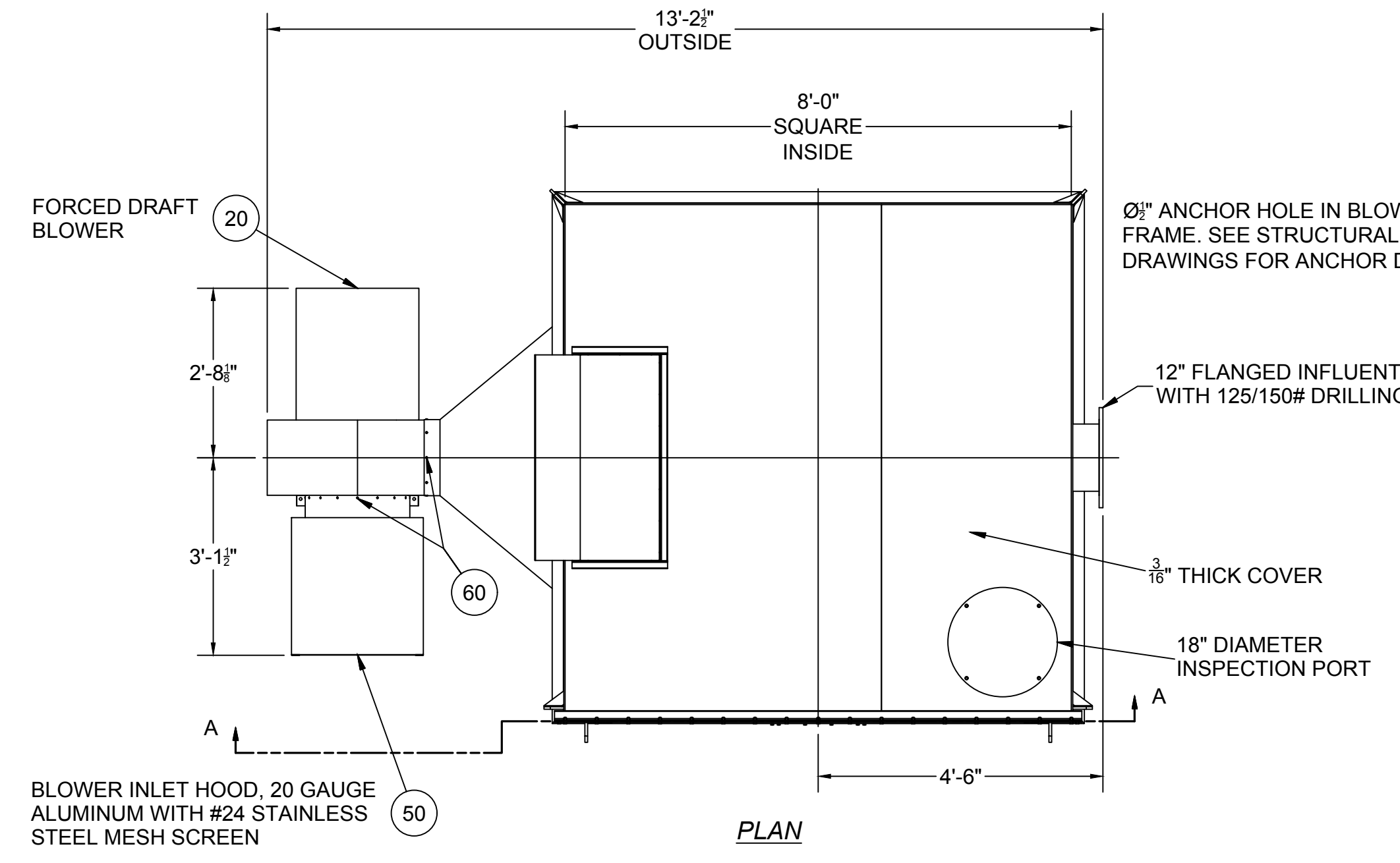

PLAN

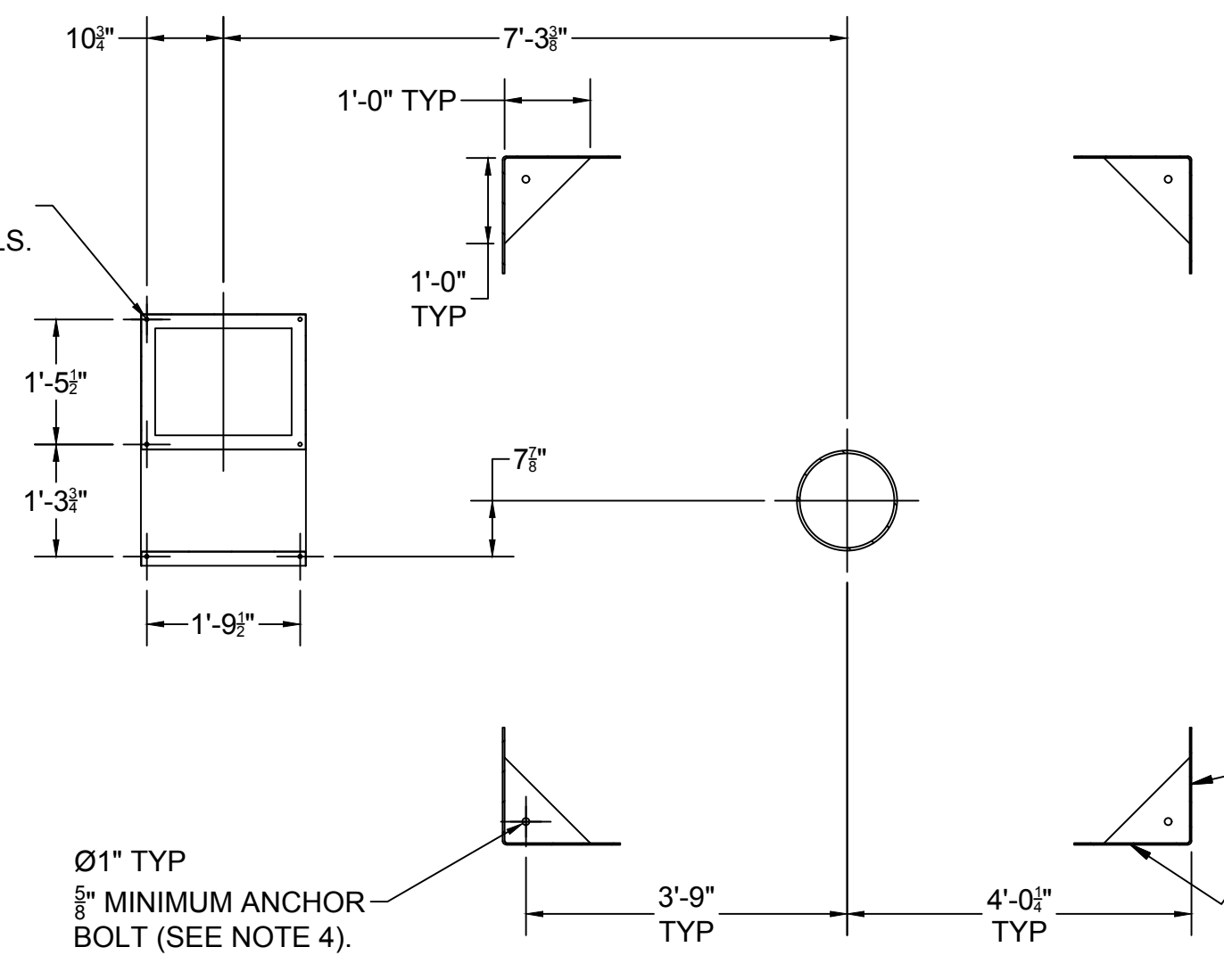

SECTION B-B

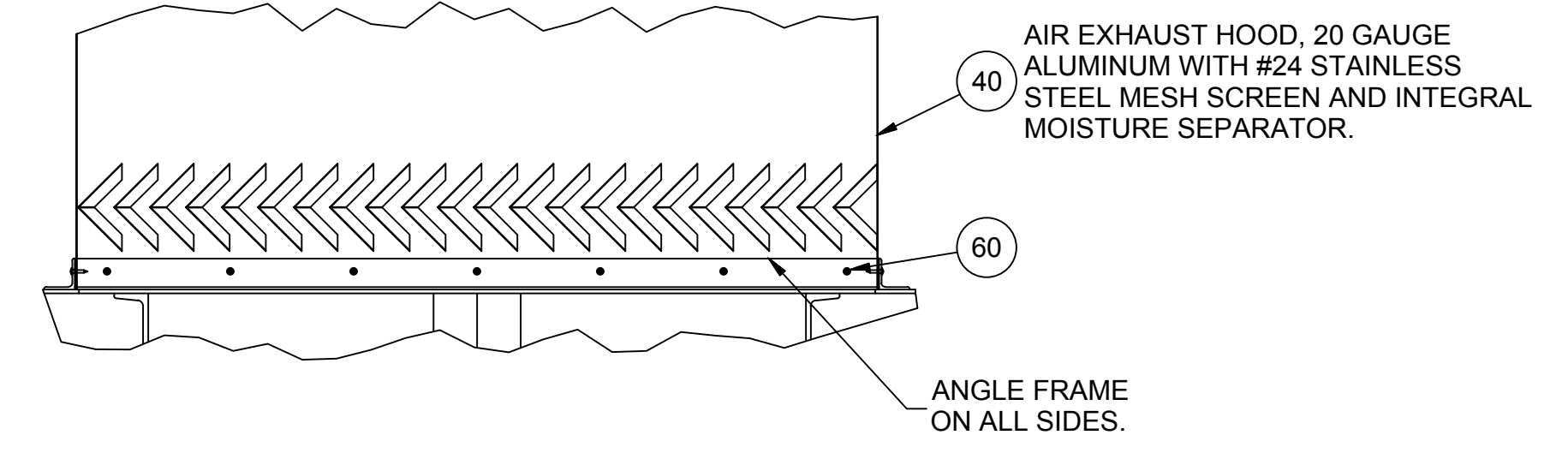

DETAIL A
SCALE: 1 1/2" = 1'-0"

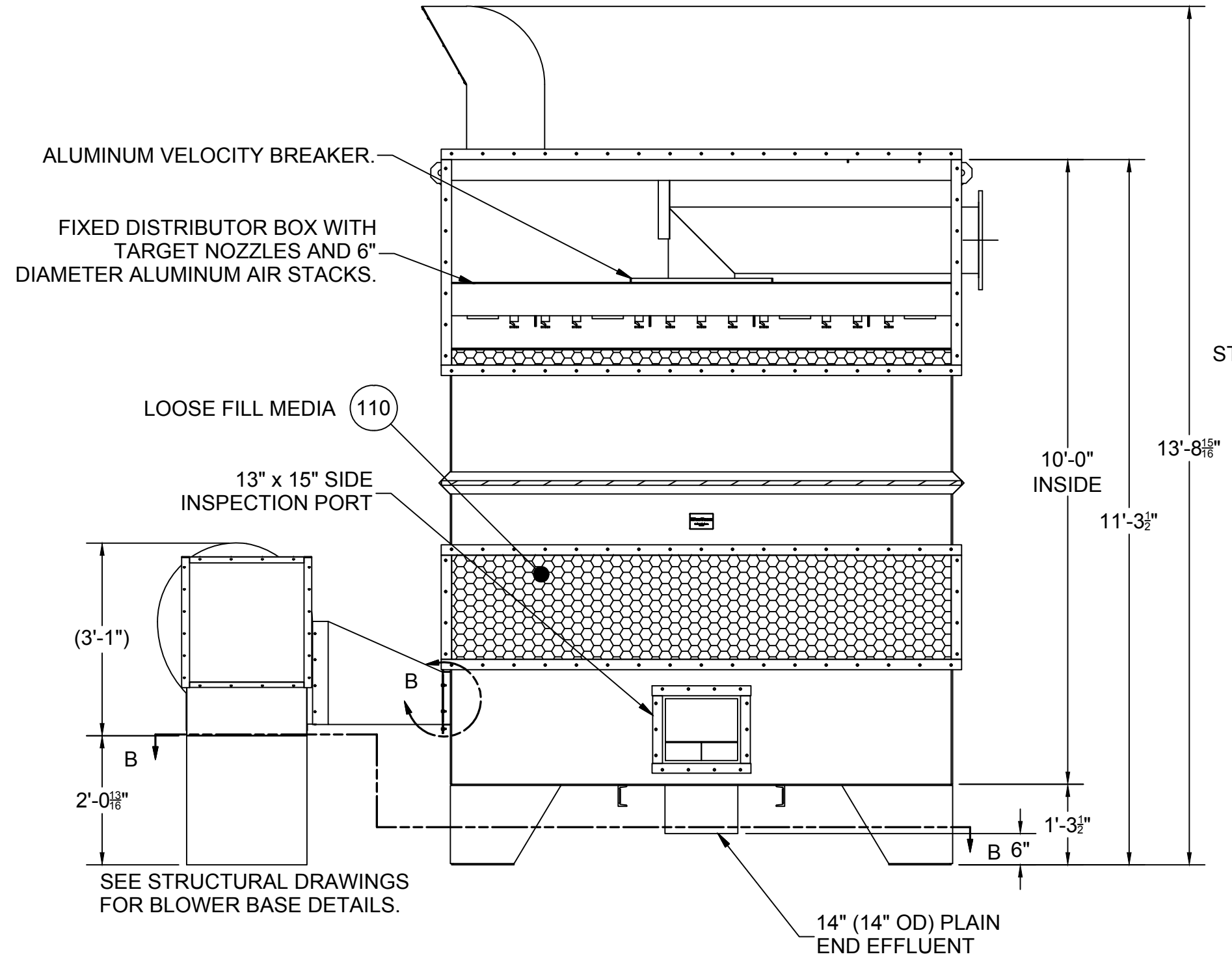

SECTION A-A

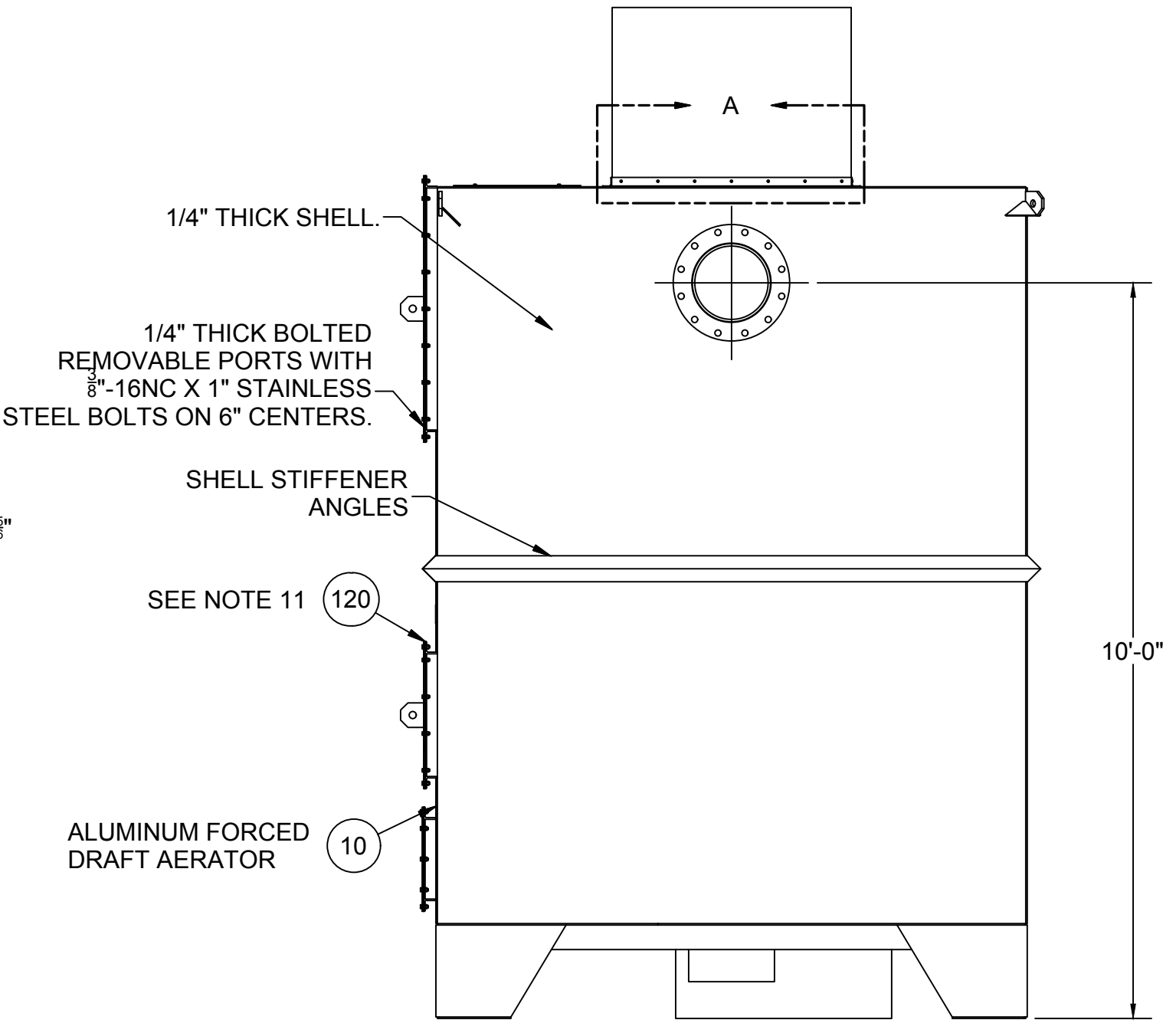

SIDE ELEVATION

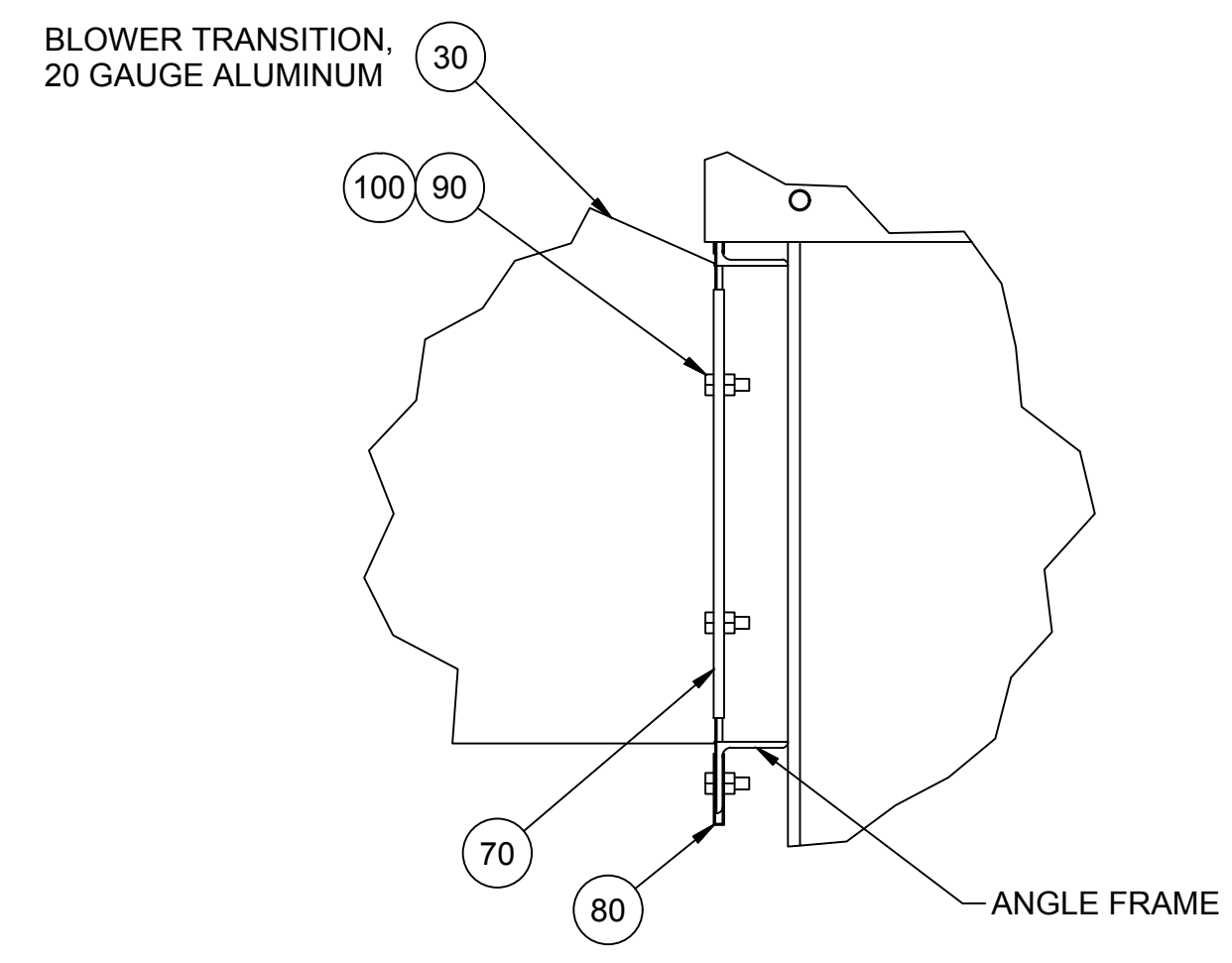

DETAIL B
SCALE: 3" = 1'-0"

- ADDITIONAL NOTES:**
- 1.) AERATOR IS SHIPPED FULLY ASSEMBLED EXCEPT FOR SOME AIR HANDLING EQUIPMENT. REFER TO BILL OF MATERIAL FOR IDENTIFICATION OF FIELD ASSEMBLED ITEMS.
 - 2.) ALL AERATOR PLATE IS TO BE 3003 ALUMINUM. STRUCTURALS TO BE 6061 ALUMINUM.
 - 3.) THE AERATOR SHALL BE WELDED INSIDE AND OUTSIDE WITH FILLET WELDS EQUAL TO THE THICKNESS OF THE PLATES. ALL MAIN HOUSING SEAM WELDS SHALL BE DYE PENETRANT CHECKED AT THE FACTORY BEFORE SHIPMENT TO ENSURE THEY ARE WATERTIGHT.
 - 4.) THE MAXIMUM ANCHOR BOLT DIAMETER IS 7/8". THE MINIMUM WASHER DIAMETER IS 2" FOR ALL ANCHOR SIZES. SEE STRUCTURAL DRAWINGS FOR ANCHOR DETAILS.
 - 5.) FLANGE BOLT HOLE PATTERN IS TO STRADDLE UNIT CENTERLINE.
 - 6.) AERATOR INLET AND EFFLUENT PIPE STUBS ARE NOT DESIGNED TO SUPPORT INLET AND EFFLUENT PIPING. ADDITIONAL PIPE SUPPORTS SHOULD BE USED BUT WILL BE SUPPLIED BY OTHERS.
 - 7.) INFLUENT AND EFFLUENT PIPE MOUNTING HARDWARE AND GASKETS ARE PROVIDED BY OTHERS.
 - 8.) IF INSTALLATION INSTRUCTIONS ARE NOT CLEARLY UNDERSTOOD, CONSULT WESTTECH ENGINEERING INC. FOR ADDITIONAL INFORMATION BEFORE COMMENCING ERECTION.
 - 9.) IMPROPER STORAGE, HANDLING, INSTALLATION, OR FIELD MODIFICATIONS OF EQUIPMENT MAY RESULT IN DAMAGE AND LOSS OF WARRANTY PROTECTION.
 - 10.) THE BLOWER MOTOR MUST BE WIRED CORRECTLY TO THE VOLTAGE LISTED ON THE UNIT.
 - 11.) PLACE 3/8" BEAD OF BLUE PERMATAX SEALANT (PIECE 120) ON PORT COVERS INSIDE OF BOLT PATTERN BEFORE INSTALLING BOLTS.
 - 12.) AERATOR MEDIA SHIPPED LOOSE FOR FIELD INSTALLATION.

COMPANY CONFIDENTIAL:
THIS DRAWING IS PROPERTY OF WESTTECH ENGINEERING, INC. AND IS TRANSMITTED IN CONFIDENCE. NEITHER RECEIPT NOR POSSESSION CONFERS OR TRANSFERS ANY RIGHTS TO REPRODUCE, USE, OR DISCLOSE, IN WHOLE OR IN PART, DATA CONTAINED HEREIN FOR ANY PURPOSE, WITHOUT THE WRITTEN PERMISSION OF WESTTECH ENGINEERING, INC.

PLOT SCALE: 0.3889:1 EDT DATE: 5/12/2019 8:34 AM EDITED BY: jgfr/rlh PPATH: \\2018\03\44\5_drawing\work\mechanical\201803\44_en_well_d01.dwg

REVISIONS		
DATE	REVISION	BY

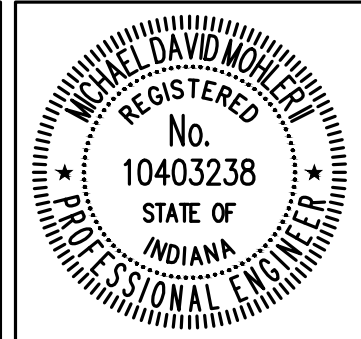

RECOMMENDED FOR APPROVAL	DATE
<i>MDM</i>	5/31/2019
DESIGNED: PAJ	DRAWN: MJG
CHECKED: MDM	CHECKED: PAJ

**WHITE RIVER WELL #3
VOC REMOVAL**

AERATOR PLAN AND SECTION

CEG PROJECT NUMBER	20WR02557
CONSULTANT PROJECT NUMBER	201800344
SHEET	C-4

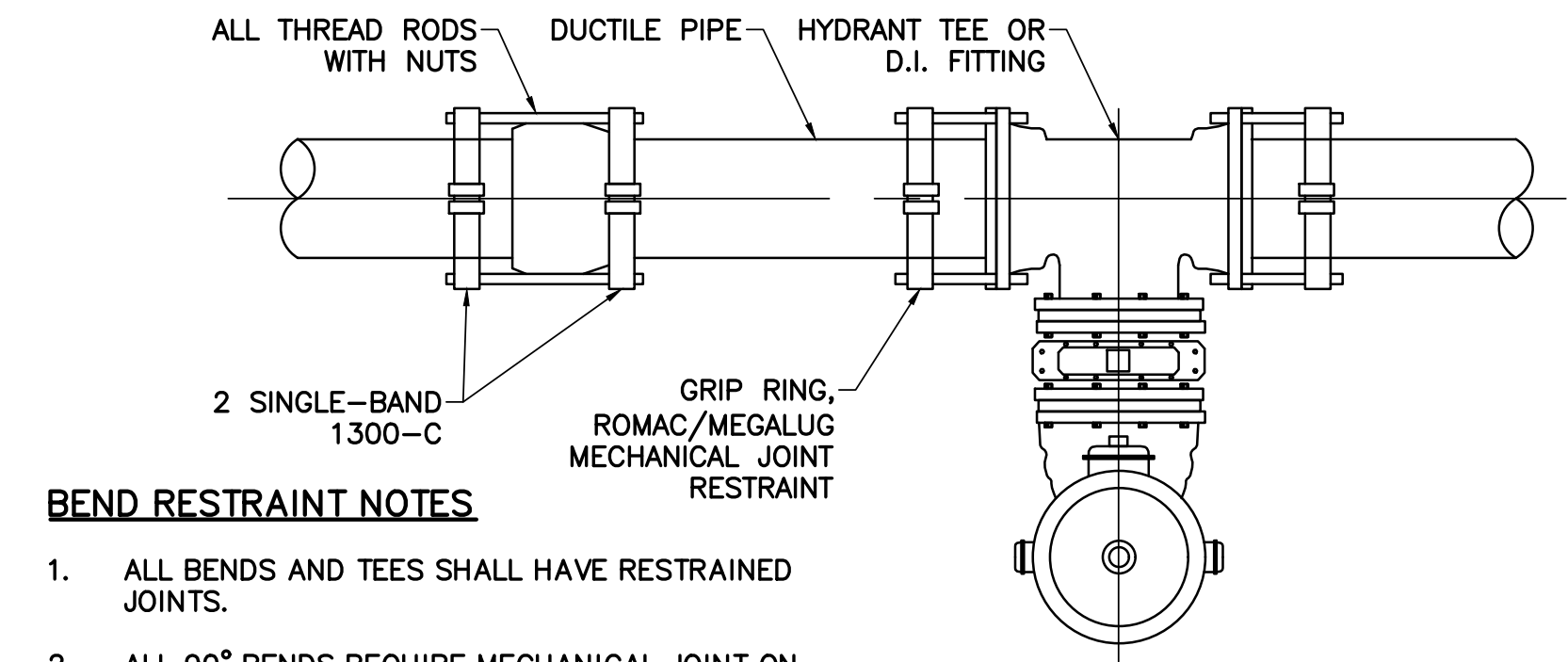
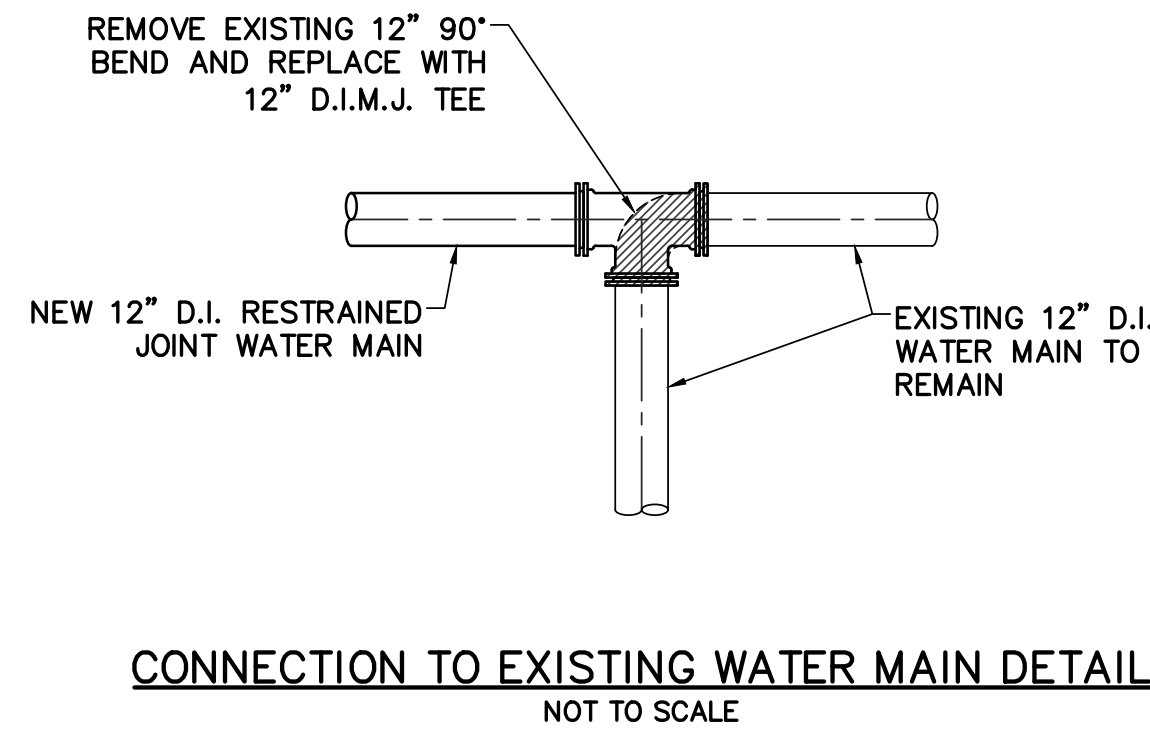
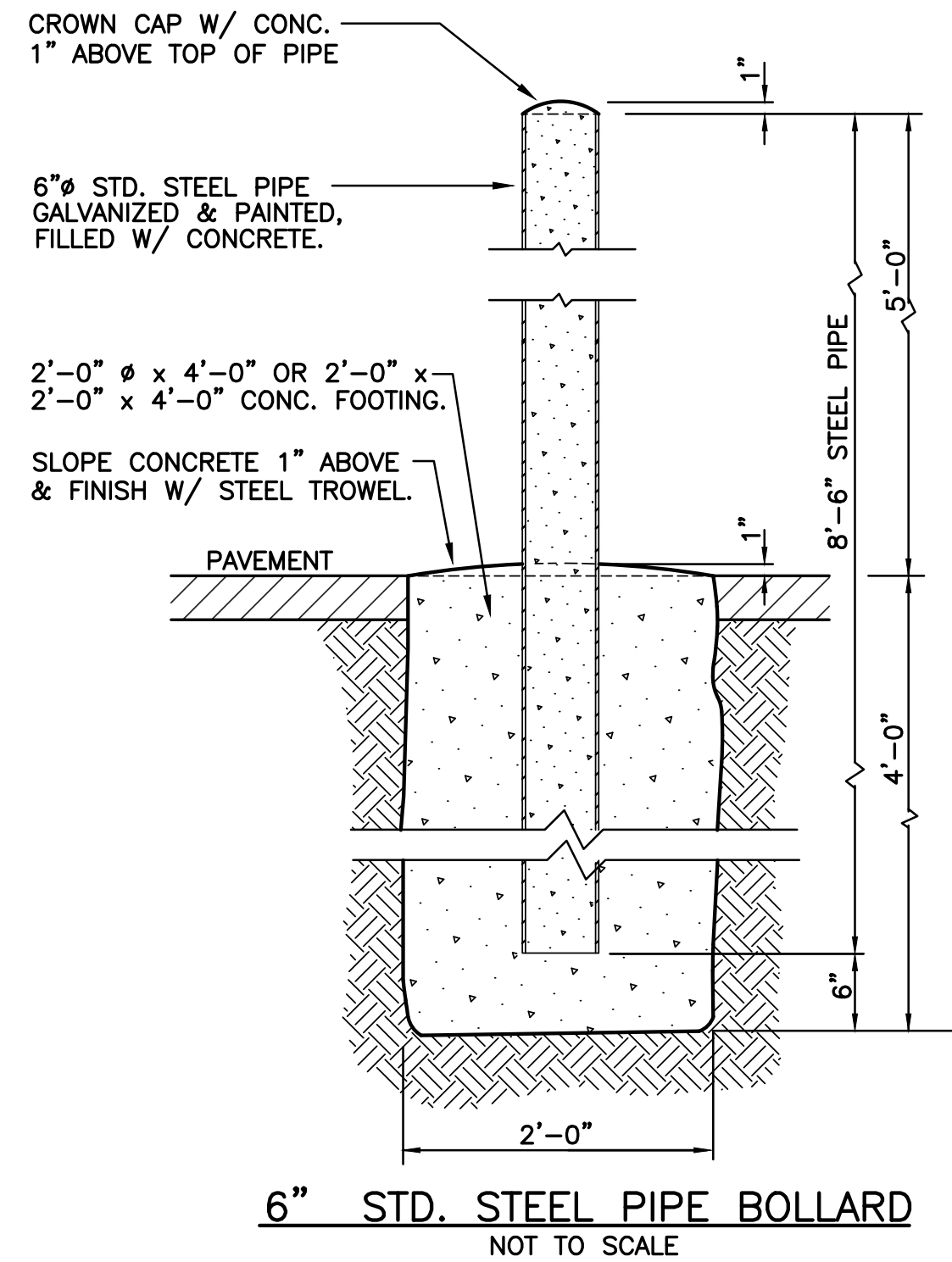

BEND RESTRAINT NOTES

1. ALL BENDS AND TEES SHALL HAVE RESTRAINED JOINTS.
2. ALL 90° BENDS REQUIRE MECHANICAL JOINT ON EACH SIDE OF FITTING.
3. JOINT RESTRAINT IS REQUIRED ON EACH SIDE OF FITTING ONE PIPE JOINT AWAY.
4. ALL 90° BENDS REQUIRE A THRUST BLOCK.

JOINT RESTRAINT DETAIL
NOT TO SCALE

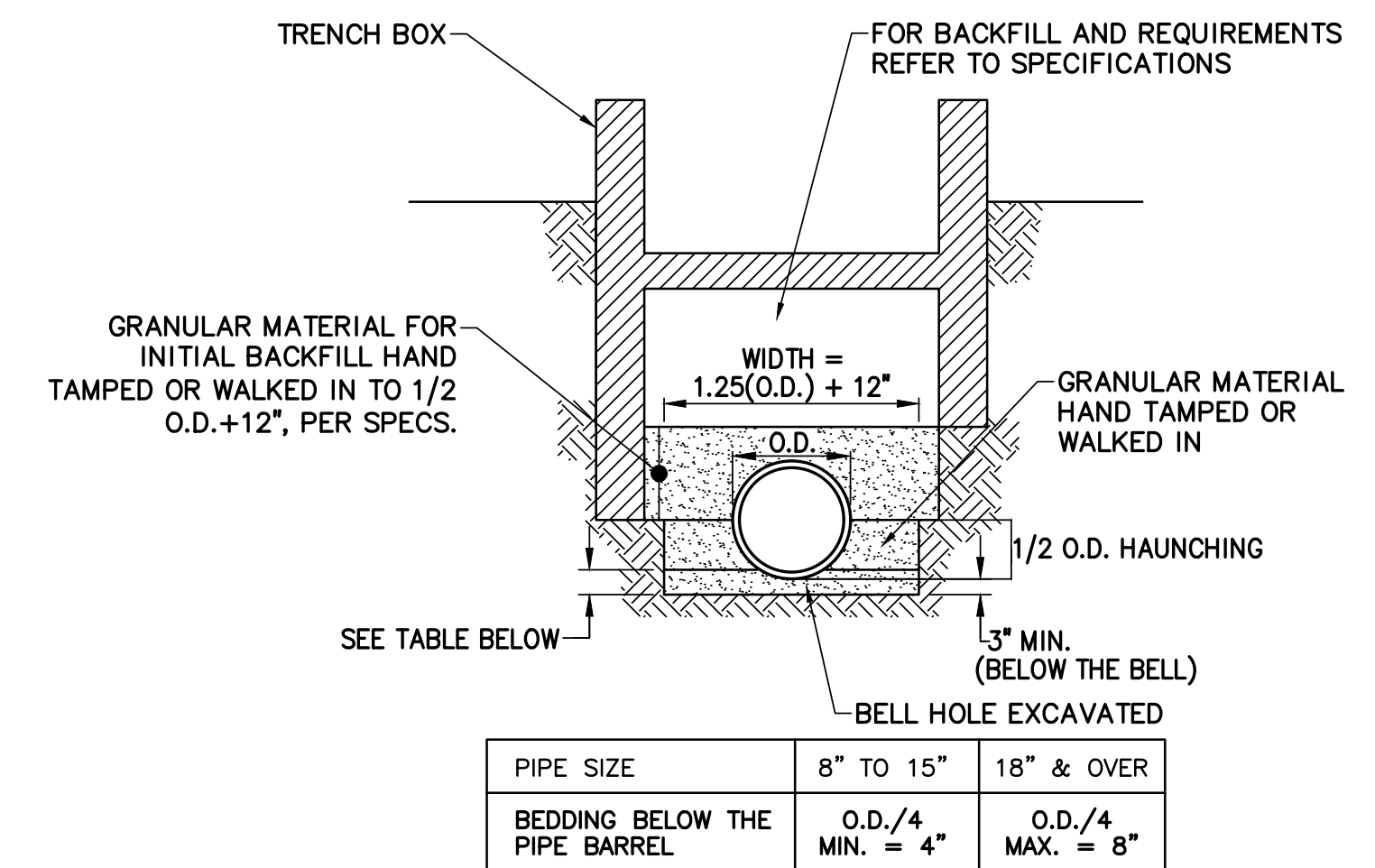
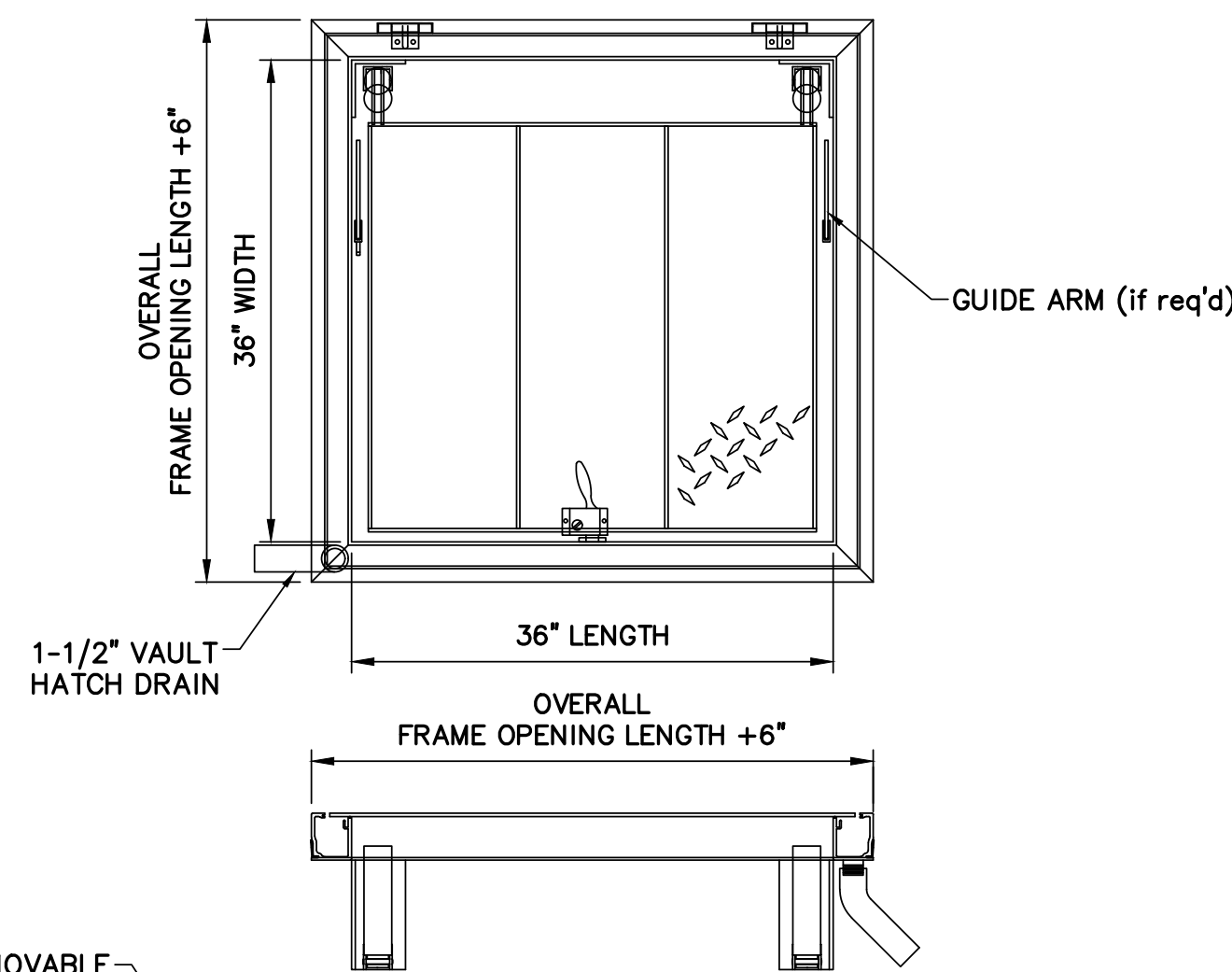

BACKFILL NOTES

1. FINAL BACKFILL (FROM 12 INCHES ABOVE TOP OF PIPE) SHALL BE COMPACTED GRANULAR MATERIAL PER SPECIFICATIONS WHEN THE TRENCH IS UNDER OR WITHIN 5 FEET OF PAVEMENT.
2. FINAL BACKFILL SHALL BE NATIVE MATERIAL IN AREAS WHEN THE TRENCH IS MORE THAN 5 FEET FROM PAVEMENT, COMPACTED TO PREVENT SETTLEMENT.
3. HAUNCHING AND INITIAL BACKFILL SHALL BE INSTALLED IN 6 INCH LIFTS.
4. FINAL BACKFILL SHALL BE PLACED IN SUCH A MANNER THAT WILL NOT DISTURB THE PIPE.
5. COMPACTION SHALL BE PER SPECIFICATIONS.

PIPE BEDDING DETAIL (DUCTILE IRON)
NOT TO SCALE

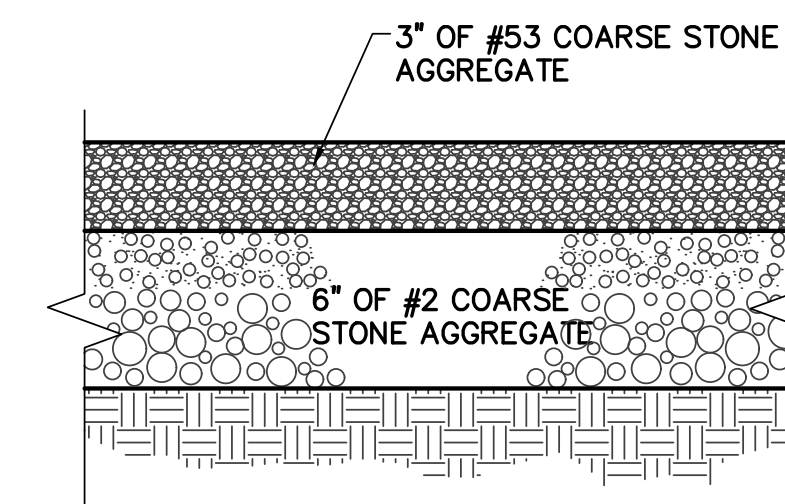

TYPICAL GRAVEL PAVEMENT SECTION
NOT TO SCALE

CITIZENS WATER STANDARD PRACTICE B

REVISION DATE: 1/26/2015 ISSUE DATE: 6/8/2009

STANDARD HYDRANT SETTING FOR WATER MAIN SIZES 12" OR LARGER IN CITIZENS WATER AND 6" OR LARGER IN CITIZENS WESTFIELD.

NOTES:

1. FOR INSTALLATION ON 12" & LARGER DISTRIBUTION MAIN IN CITIZENS WATER TERRITORY.
2. FOR INSTALLATION ON 6" & LARGER DISTRIBUTION MAIN IN CITIZENS WESTFIELD TERRITORY.
3. ALL HYDRANTS SHALL BE RESTRAINED TO THE HYDRANT TEE WITH DUCTILE IRON BRANCH PIPING ENCASED IN POLYETHYLENE WRAP.
4. SWIVEL 90° BEND MAY BE USED TO INSTALL HYDRANT AND VALVE IN GRASS STRIP BETWEEN CURB & SIDEWALK.
5. A MANUFACTURED "OUT OF SERVICE" SIGN WILL BE REQUIRED ON HYDRANTS UNTIL MAIN HAS BEEN PLACED "IN SERVICE" BY THE INSPECTOR.

APPENDIX C-3

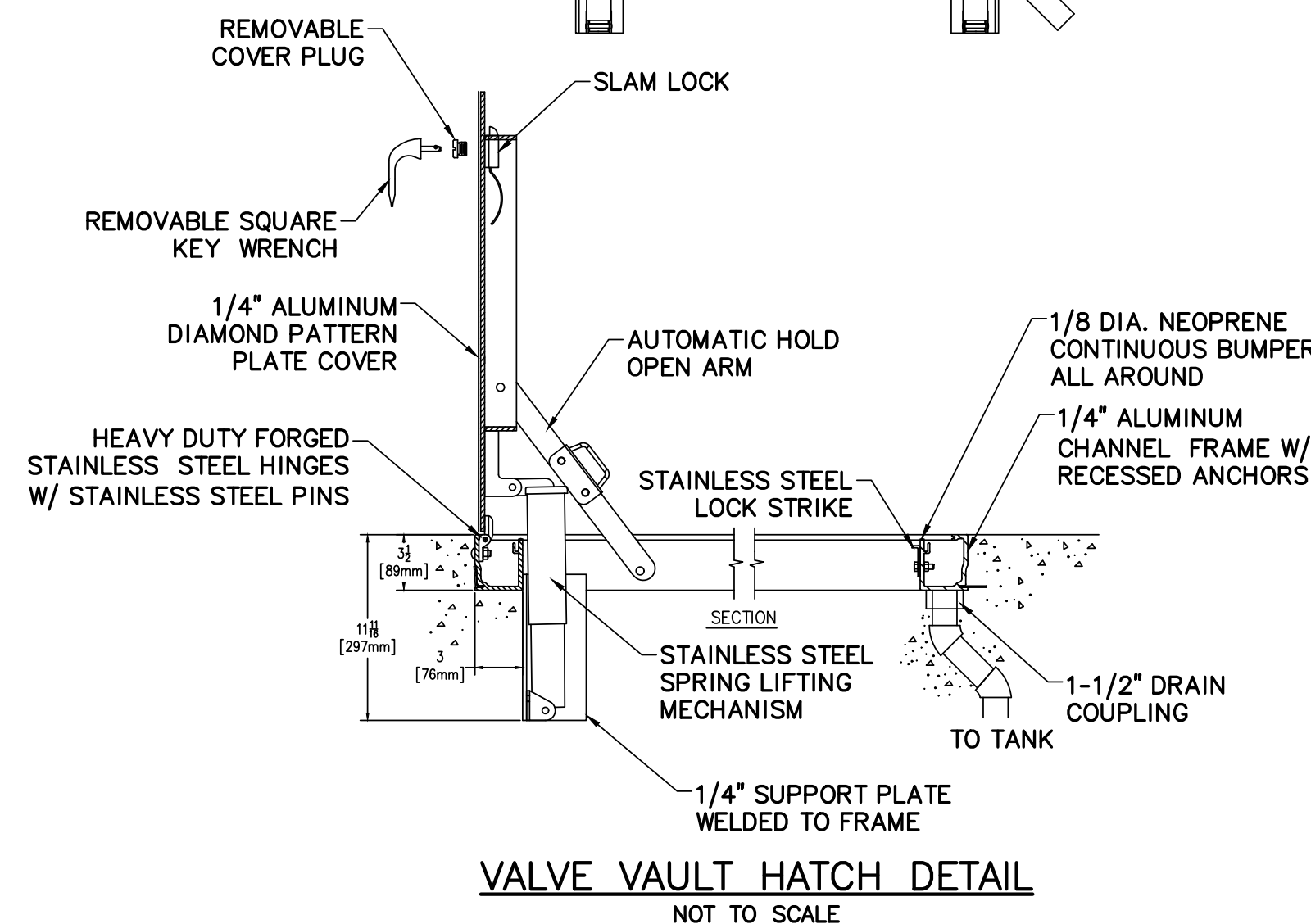

REVISIONS		
DATE	REVISION	BY

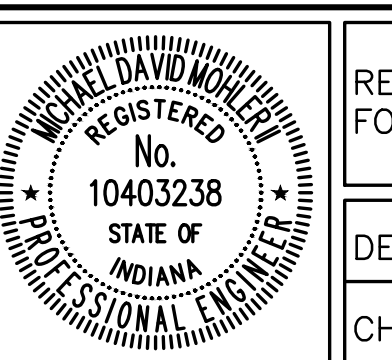

RECOMMENDED FOR APPROVAL	<i>MDM</i>	5/31/2019
DESIGNED:	PAJ	DRAWN:
CHECKED:	MDM	CHECKED:
		PAJ

**WHITE RIVER WELL #3
VOC REMOVAL**

MISCELLANEOUS DETAILS

CEG PROJECT NUMBER	20WR02557
CONSULTANT PROJECT NUMBER	201800344
SHEET	C-5

PLOT SCALE: 1:1 EDIT DATE: 6/7/2019 3:17 PM EDITED BY: jgrrh. PATH: C:\2018\00344\1.dwg

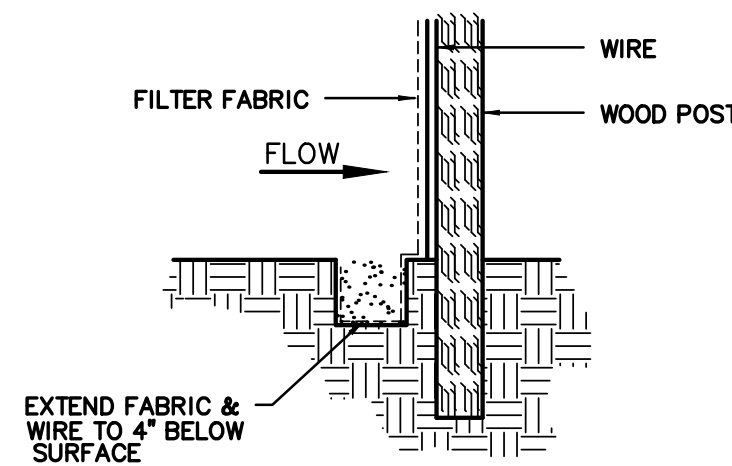
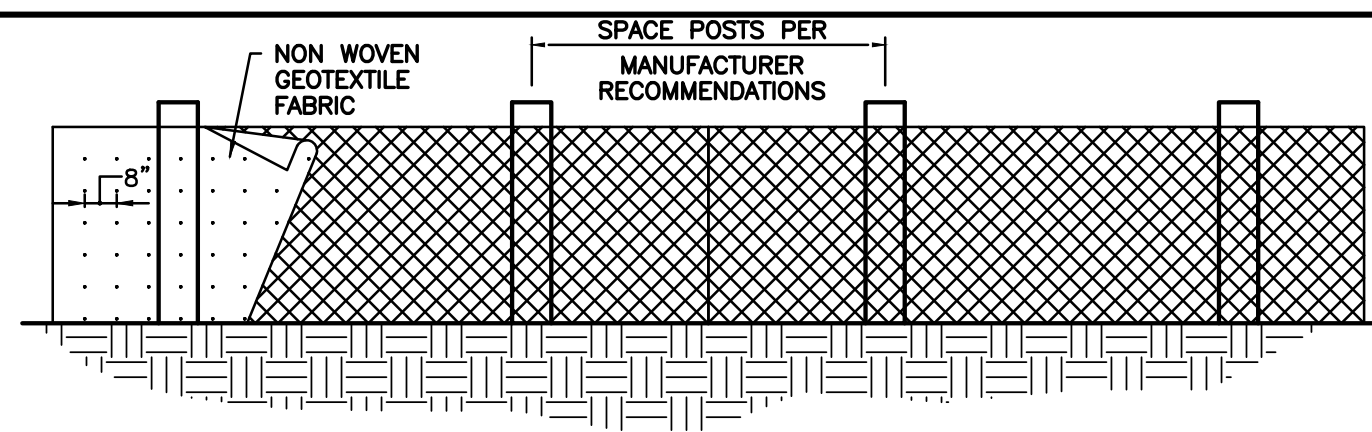

SILT FENCE CONSTRUCTION
NOT TO SCALE

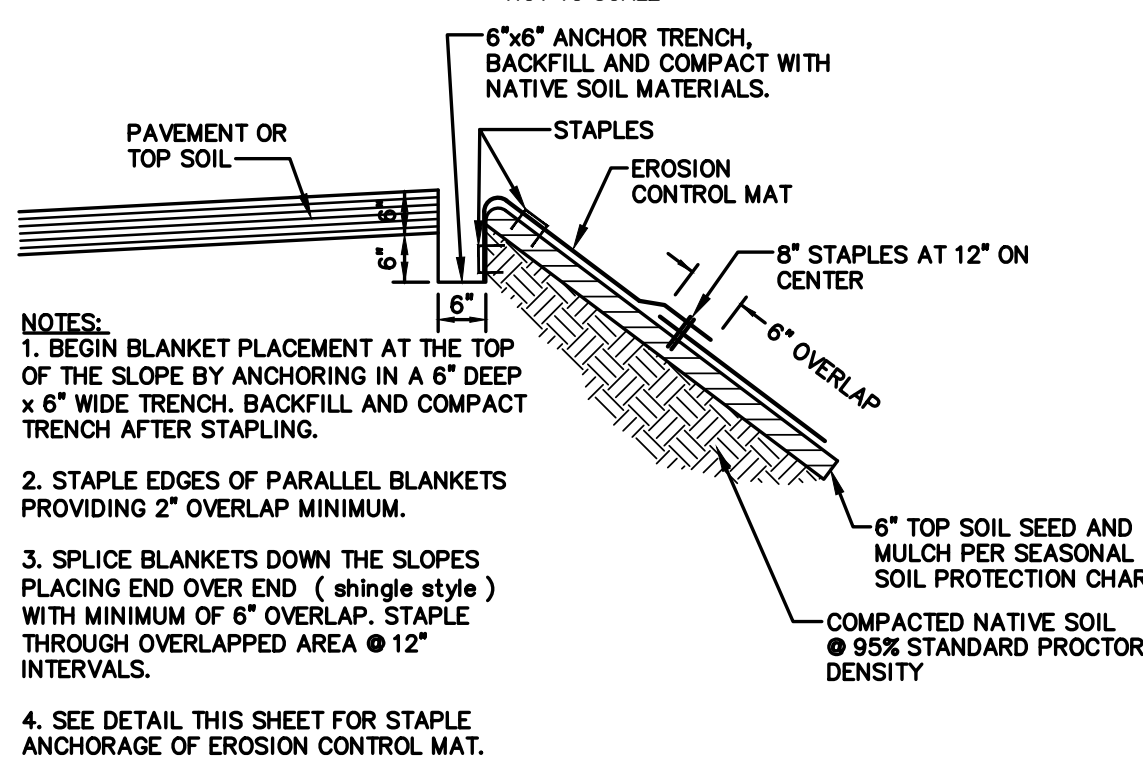

NOTES:
1. BEGIN BLANKET PLACEMENT AT THE TOP OF THE SLOPE BY ANCHORING IN A 6" DEEP x 6" WIDE TRENCH. BACKFILL AND COMPACT TRENCH AFTER STAPLING.
2. STAPLE EDGES OF PARALLEL BLANKETS PROVIDING 2" OVERLAP MINIMUM.
3. SPLICE BLANKETS DOWN THE SLOPES PLACING END OVER END (shingle style) WITH MINIMUM OF 6" OVERLAP. STAPLE THROUGH OVERLAPPED AREA @ 12" INTERVALS.
4. SEE DETAIL THIS SHEET FOR STAPLE ANCHORAGE OF EROSION CONTROL MAT.

EROSION CONTROL MAT FOR SLOPE STABILIZATION
NOT TO SCALE

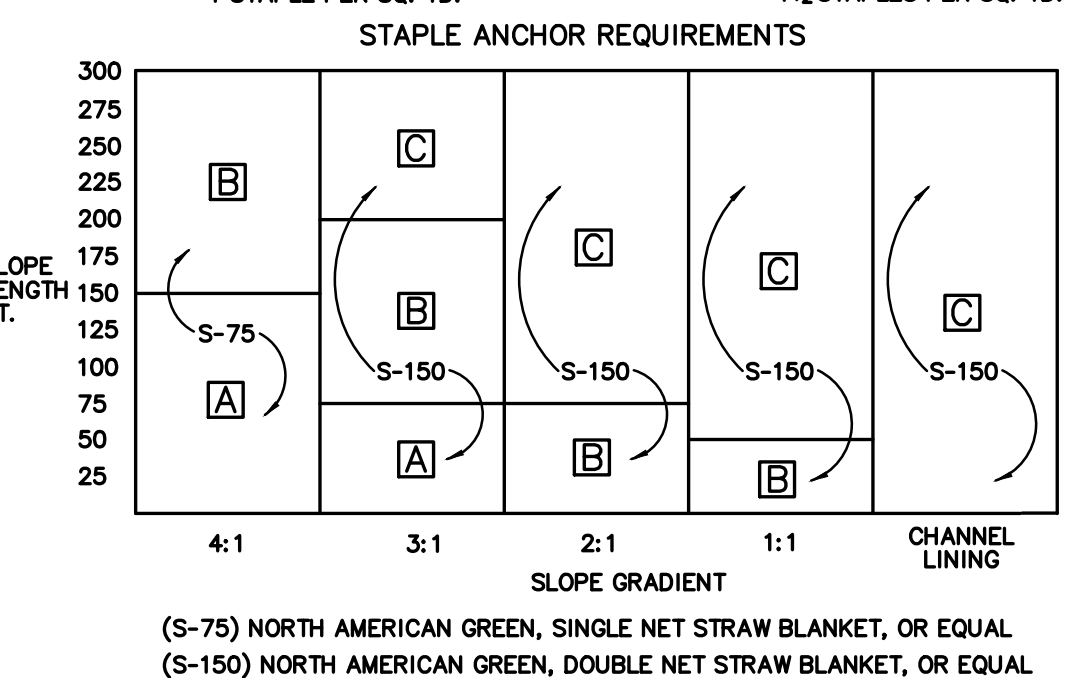
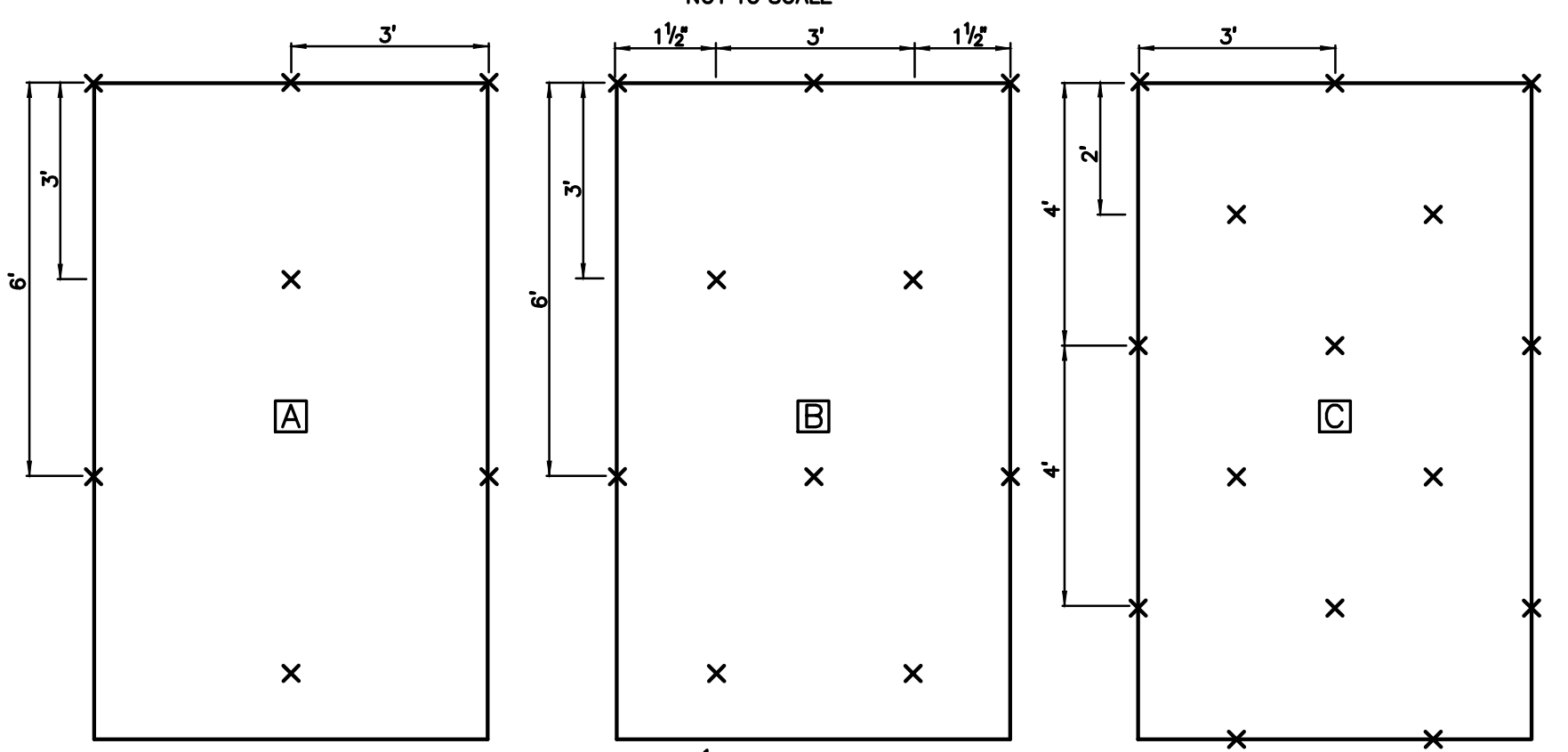

NOTES:
CHANNEL LININGS UTILIZE STAPLE PATTERN "C" WITH ADDITIONAL STAPLES ON SIDE SLOPES AT PROJECTED WATER LINE.
STAPLE PATTERNS APPLY TO ALL NORTH AMERICAN GREEN EROSION CONTROL BLANKETS. STAPLE PATTERNS MAY VARY DEPENDING UPON SOIL TYPE AND AVERAGE RAINFALL.
AT SLOPE LENGTHS GREATER THAN 300 FEET OR WHERE DRAINAGE OVER LARGE AREAS IS DIRECTED ONTO THE BLANKETS, USE STAPLE PATTERN "C".

EROSION CONTROL MAT ANCHORAGE
NOT TO SCALE

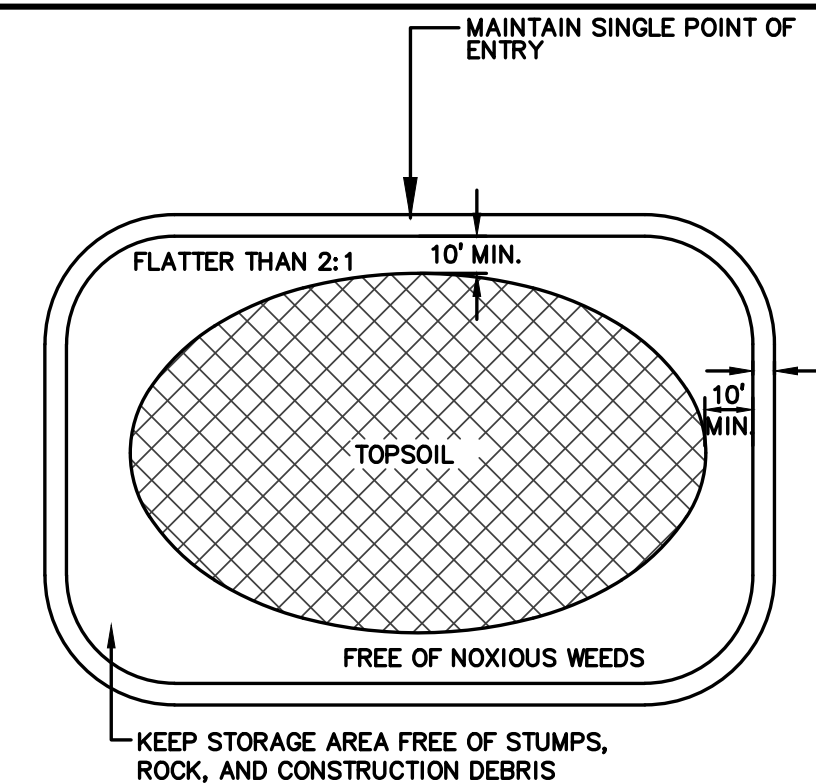

TOPSOIL STOCKPILE
NOT TO SCALE

SILT FENCE OR 1' SOIL BERM CONTRACTOR TO INSPECT WEEKLY OR AFTER EVERY 0.5" RAIN EVENT AND REPAIR/MAINTAIN AS REQUIRED

KEEP STORAGE AREA FREE OF STUMPS, ROCK, AND CONSTRUCTION DEBRIS

SEASONAL SOIL PROTECTION CHART												
STABILIZATION PRACTICE	JAN.	FEB.	MAR.	APR.	MAY	JUNE	JULY	AUG.	SEPT.	OCT.	NOV.	DEC.
PERMANENT SEEDING SUN TO PARTIAL SHADE			A		*			*	*/ /			
PERMANENT SEEDING PARTIAL SHADE TO SHADE			B		*			*	*/ /			
PERMANENT SEEDING NON-IRRIGATED AREAS			C		*			*	*/ /			
TEMPORARY SEEDING			D						E			
MULCHING			G									

A = PERMANENT SEEDING - SUN TO PARTIAL SHADE KENTUCKY BLUEGRASS 175 LBS./ACRE; CREEPING RED FESCUE 70 LBS./ACRE; FINE TEXTURED RYE (PERENNIAL) 105 LBS./ACRE PLUS 2 TONS STRAW MULCH/ACRE, OR ADD ANNUAL RYE GRASS 20 LBS./ACRE
 B = PERMANENT SEEDING - PARTIAL SHADE TO SHADE KENTUCKY BLUEGRASS 35 LBS./ACRE; CREEPING RED FESCUE 210 LBS./ACRE; FINE TEXTURED RYE (PERENNIAL) 105 LBS./ACRE PLUS 2 TONS STRAW MULCH/ACRE, OR ADD ANNUAL RYE GRASS 20 LBS./ACRE
 C = PERMANENT SEEDING - NON-IRRIGATED AREAS KENTUCKY BLUEGRASS 87 LBS./ACRE; CREEPING RED FESCUE 70 LBS./ACRE; FINE TEXTURED RYE (PERENNIAL) 193 LBS./ACRE PLUS 2 TONS STRAW MULCH/ACRE, OR ADD ANNUAL RYE GRASS 20 LBS./ACRE
 D = SPRING OATS 3 BUSHELS/ACRE
 E = WHEAT OR RYE 2 BUSHELS/ACRE
 F = ANNUAL RYE GRASS 40 LBS./ACRE (1 LB/1000 SQ. FT.)
 G = STRAW MULCH 2 TONS/ACRE. ANCHOR WITH ASPHALT EMULSION AT A RATE OF 300/GAL. PER ACRE FOR SLOPES GREATER THAN 4:1 USE EROSION CONTROL BLANKET ACCEPTABLE TO LOCAL AUTHORITIES.

|/| = IRRIGATION NEEDED DURING JUNE, JULY, AUGUST AND/OR SEPTEMBER
NOTE: CONTRACTOR IS RESPONSIBLE FOR PROVIDING TEMPORARY SEEDING TO CONTROL EROSION AS REQUIRED BY INDIANA DEPARTMENT OF ENVIRONMENTAL MANAGEMENT.

EROSION CONTROL NOTES

- CONTRACTOR SHALL COMPLY WITH ALL STATE AND LOCAL ORDINANCES THAT APPLY.
- THIS PLAN SHALL NOT BE CONSIDERED ALL INCLUSIVE AS THE CONTRACTOR SHALL TAKE ALL NECESSARY PRECAUTIONS TO PREVENT SEDIMENT FROM LEAVING THE SITE.
- ADDITIONAL EROSION AND SEDIMENT CONTROL MEASURES SHALL BE INSTALLED IF DEEMED NECESSARY BY ON SITE INSPECTION BY THE LOCAL REVIEWING AUTHORITY.
- WASTES AND UNUSED BUILDING MATERIALS SHALL NOT BE ALLOWED TO BE CARRIED FROM THE SITE BY STORM WATER RUNOFF. PROPER DISPOSAL OF ALL WASTES AND UNUSED BUILDING MATERIALS IS REQUIRED.
- SEDIMENT BEING TRACKED ONTO PUBLIC OR PRIVATE ROADWAYS SHALL BE MINIMIZED. CLEARED SEDIMENT SHALL BE RETURNED TO THE SITE FOR DISPOSAL.
- EXISTING VEGETATION SHALL BE PRESERVED IN AREAS NOT DISTURBED BY CONSTRUCTION ACTIVITY.
- IF SOIL STOCKPILES WILL BE LEFT FOR A PERIOD LONGER THAN FIFTEEN (15) DAYS, THEY SHALL BE STABILIZED WITH TEMPORARY SEED MIX AND SURROUNDED BY SILT FENCE.
- ALL APPLICABLE EROSION CONTROL MEASURES SHALL BE PLACED BEFORE ANY LAND DISTURBING ACTIVITIES.
- UNVEGETATED AREAS THAT ARE SCHEDULED OR LIKELY TO BE LEFT INACTIVE FOR FIFTEEN (15) DAYS OR MORE MUST BE TEMPORARILY OR PERMANENTLY SEEDED. ALTERNATIVE STABILIZATION METHODS ARE ACCEPTABLE IF THEY ARE ADEQUATE TO PREVENT SEDIMENT DISCHARGE.
- ANY DEWATERING ACTIVITIES SHALL BE PERFORMED IN A MANNER THAT WILL NOT DISCHARGE SEDIMENT LADEN WATER INTO A STREAM OR STORMWATER INLET. SEDIMENT LADEN WATER SHALL BE FILTERED THROUGH A PUMP DISCHARGE FILTER DEVICE SUCH AS A PUMP DISCHARGE BAG. PUMP DISCHARGE SHALL BE PLACED IN AN AREA THAT WILL NOT CAUSE EROSION AT THE OUTLET.
- THE CONTRACTOR SHALL ENSURE THAT ALL APPLICABLE EROSION AND SEDIMENT CONTROL MEASURES ARE IN PLACE AT THE APPROPRIATE PHASES OF CONSTRUCTION.
- IF CONTRACTOR WORKS OUTSIDE THE ESTABLISHED CONSTRUCTION LIMITS, SILT FENCE MAY BE REQUIRED. CONTRACTOR IS RESPONSIBLE FOR ANY WORK OUTSIDE THE CONSTRUCTION LIMITS AT NO COST TO THE OWNER.
- THE CONTRACTOR SHALL DEVELOP A SELF-MONITORING PROGRAM TO ENSURE PROPER MAINTENANCE AND FUNCTION OF STORM WATER QUALITY MEASURES. A WRITTEN EVALUATION SHOULD BE PERFORMED BY THE END OF THE NEXT BUSINESS DAY AFTER EACH MEASURABLE STORM EVENT, AND AT A MINIMUM OF ONE (1) TIME PER WEEK. WRITTEN EVALUATION SHALL INCLUDE THE NAME OF THE INDIVIDUAL PERFORMING THE EVALUATION, DATE OF THE EVALUATION, PROBLEMS IDENTIFIED AT THE SITE, AND DETAILS OF CORRECTIVE ACTIONS RECOMMENDED AND COMPLETED. MONITORING SHOULD BE PERFORMED BY AN INDIVIDUAL TRAINED IN EROSION AND SEDIMENT CONTROL PRACTICES.

MATERIAL HANDLING AND SPILL PREVENTION PLAN
 MATERIALS PRESENT ON-SITE THAT MAY BE POTENTIALLY HAZARDOUS WILL INCLUDE WASTES, EXCESS BUILDING MATERIALS, AND FUELS AND LUBRICANTS REQUIRED FOR CONSTRUCTION EQUIPMENT. THESE ITEMS SHALL NOT BE ALLOWED TO BE CARRIED FROM THE SITE BY STORM WATER RUNOFF. THE CONTRACTOR SHALL DISPOSE OF ALL EXCESS BUILDING MATERIALS AND CONTAINERS AT AN OFF-SITE LOCATION. CONSTRUCTION VEHICLES SHALL BE SERVICED IN AREAS THAT WILL MINIMIZE IMPACTS IN THE OCCURRENCE OF A SPILL OR LEAK. SHOULD A SPILL OCCUR, THE CONTRACTOR SHALL MAKE ALL EFFORTS TO CONTAIN AND CLEAN THE SPILL, AND EXPOSE OF CONTAMINATED MATERIALS/SOIL IN AN APPROVED MANNER. ALL SPILLS SHOULD BE REPORTED TO THE INDIANA DEPARTMENT OF ENVIRONMENTAL MANAGEMENT'S EMERGENCY RESPONSE HOT LINE AT 1-888-233-7745.

MAINTENANCE REQUIREMENTS FOR EROSION CONTROL MEASURES

- SILT FENCE MAINTENANCE REQUIREMENTS**
- INSPECT THE SILT FENCE PERIODICALLY AND AFTER EACH STORM EVENT.
 - IF FABRIC TEARS, STARTS TO DECOMPOSE, OR IN ANY WAY BECOMES INEFFECTIVE, REPLACE THE AFFECTED PORTION IMMEDIATELY.
 - REMOVE DEPOSITED SEDIMENT WHEN IT REACHES HALF THE HEIGHT OF THE FENCE AT ITS LOWEST POINT OR IS CAUSING THE FABRIC TO BULGE.
 - TAKE CARE TO AVOID UNDERMINING THE FENCE DURING CLEAN OUT.
 - AFTER THE CONTRIBUTING DRAINAGE AREA HAS BEEN STABILIZED REMOVE THE FENCE AND SEDIMENT DEPOSITS, BRING THE DISTURBED AREA TO GRADE, AND STABILIZE.
- EROSION CONTROL BLANKET (SURFACE APPLIED) MAINTENANCE REQUIREMENTS**
- DURING VEGETATIVE ESTABLISHMENT INSPECT AFTER STORM EVENTS FOR ANY EROSION BELOW THE BLANKET.
 - IF ANY AREA SHOWS EROSION PULL BACK THAT PORTION OF THE BLANKET COVERING IT, ADD SOIL, RE-SEED THE AREA, AND RE-LAY AND STAPLE THE BLANKET.
 - AFTER VEGETATIVE ESTABLISHMENT CHECK THE TREATED AREA PERIODICALLY.

PLOT SCALE: 1" = 10' DATE: 6/7/2019 3:17 PM EDITED BY: jgfrith PARTS: 2018/05/24/14 drawings/revision/201800344.er.dwg

REVISIONS		
DATE	REVISION	BY

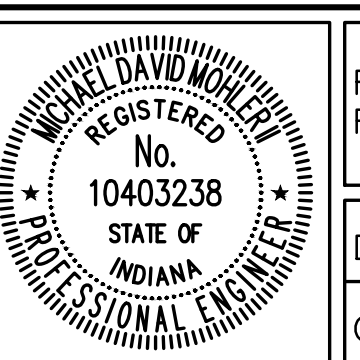

RECOMMENDED FOR APPROVAL	<i>MDM</i>	5/31/2019
DESIGNED:	PAJ	DRAWN:
CHECKED:	MDM	CHECKED:
		PAJ

WHITE RIVER WELL #3
VOC REMOVAL

EROSION CONTROL DETAILS

CEG PROJECT NUMBER	20WR02557
CONSULTANT PROJECT NUMBER	201800344
SHEET	C-6

DESIGN DATA

1. SOILS
ALLOWABLE NET BEARING PRESSURE _____ 2,000 PSF
SUBGRADE MODULUS (k) _____ 100 Pcf
LATERAL PRESSURE DESIGN
AT REST PRESSURE COEFFICIENT K₀ _____ 0.5
SURCHARGE _____ 200 PSF
DESIGN GROUND WATER TABLE ELEVATION _____ 694.00
2. CONCRETE COMPRESSIVE STRENGTH _____ SEE CONCRETE SCHEDULE
3. REINFORCING STEEL
WELDED WIRE FABRIC _____ ASTM A-68
OTHERWISE _____ A615, GRADE 60
4. DESIGN LIVE LOAD _____ 100 PSF
5. GOVERNING BUILDING CODES:
2014 INDIANA BUILDING CODE
ASG STANDARD 7-10
ACI 308.06

GENERAL

THE STRUCTURE HAS BEEN DESIGNED FOR IN-SERVICE LOADS ONLY. THE MEANS, METHODS, AND SEQUENCE OF CONSTRUCTION ARE THE SOLE RESPONSIBILITY OF THE CONTRACTOR. THE CONTRACTOR SHALL TAKE ALL NECESSARY PRECAUTIONS TO ENSURE SAFE WORKING CONDITIONS AND MAINTAIN THE INTEGRITY OF THE STRUCTURE DURING ALL STAGES OF CONSTRUCTION.

COORDINATION WITH OTHER TRADES

1. THE GENERAL CONTRACTOR SHALL COORDINATE AND CHECK ALL DIMENSIONS RELATED TO ALL SERVICES BEING PERFORMED. THE ENGINEER SHALL BE NOTIFIED OF ANY DISCREPANCIES BEFORE PROCEEDING WITH THE WORK IN THE AREA UNDER QUESTION.
2. THE CONTRACTOR SHALL NOTIFY THE ENGINEER OF ANY EQUIPMENT OR OTHER LOADS TO BE SUPPORTED BY THE STRUCTURE, NOT SHOWN ON THE STRUCTURAL CONSTRUCTION DOCUMENTS, WHOSE WEIGHT IS GREATER THAN 200 POUNDS.
3. THERE SHALL BE NO VERTICAL OR HORIZONTAL SLEEVES SET OR HOLES CUT OR DRILLED UNLESS IT IS SHOWN ON THE STRUCTURAL CONSTRUCTION DOCUMENTS OR APPROVED BY THE ENGINEER IN WRITING.
4. OPENINGS THROUGH CONCRETE SLABS AND WALLS LARGER THAN 3 INCHES IN DIAMETER, NOT SHOWN ON THE STRUCTURAL DRAWINGS, MUST BE APPROVED BY THE ENGINEER. ALL OPENINGS 8 INCHES IN DIAMETER OR LESS SHALL HAVE AT LEAST 2" OF CLEAR BETWEEN OPENINGS, UNLESS APPROVED BY THE ENGINEER. PROVIDE REINFORCING AT OPENING AS INDICATED BY THE TYPICAL OPENING IN CONCRETE WALLS DETAIL.
5. CONTRACTOR SHALL BE RESPONSIBLE FOR LOCKING AND INSTALLING EQUIPMENT ANCHOR BOLTS TO EQUIPMENT MANUFACTURERS REQUIREMENTS. ANCHOR BOLTS SHALL BE OBTAINED SO AS TO NOT CUT OR OTHERWISE DAMAGE REINFORCING STEEL.

FOUNDATIONS

1. FOUNDATION EXCAVATIONS AND SOIL RELATED WORK SHALL BE PERFORMED WITH REFERENCE TO THE NOTED ELEVATION. ALL FOOTINGS SHALL BE PREPARED BY C.T.L. ENGINEERING, INC., DATED JANUARY 24, 2019, AND SHALL BE INSPECTED BY A QUALIFIED GEOTECHNICAL ENGINEER. CONTRACTOR SHALL BECOME FAMILIAR WITH THE SURVEY AND THE SUB-SURFACE INVESTIGATION REPORT BEFORE BEGINNING CONSTRUCTION.
2. A TESTING AGENCY SHALL BE PRESENT IN ACCORD WITH DIVISION ONE OF THE PROJECT MANUAL, AND SHALL VERIFY THAT THE SOIL BEARING CAPACITY AND COMPACTION IS ACCEPTABLE IN ACCORD WITH THE SPECIFICATIONS. PROVIDE COPIES OF ALL REPORTS, VERIFICATIONS AND RECOMMENDATIONS TO THE STRUCTURAL ENGINEER.
3. PREPARE ALL AREAS OF THE SITE BY REMOVING UNSUITABLE MATERIALS, SUCH AS TOPSOIL, LOOSE FILL, ORGANICS, OR PROCEN, WET, SOFT OR LOOSE SOILS IN ACCORDANCE WITH THE CONSTRUCTION DOCUMENTS AND SOILS REPORT.
4. FOUNDATION EXCAVATIONS SHALL BE MADE TO PLAN EXCAVATIONS. PROTECT ALL THE EXPOSED SUB GRADE WITH A MEDIUM-WEIGHT ROLLER TO DETERMINE IF ANY POCKETS OF SOFT, UNSUITABLE MATERIAL EXISTS BENEATH THE EXPOSED SUB GRADE. THE SOIL CONDITIONS BENEATH FOUNDATIONS SHALL THEN BE DESCRIBED AND RECORDED BY THE GEOTECHNICAL ENGINEER. UNSUITABLE MATERIALS SHALL BE REMOVED AND RECORDED BY THE ENGINEER. LOCALIZED UNDERCUTTING AND FILLING WITH SUITABLE COMPACTED ENGINEERED FILL OR CONCRETE AS RECOMMENDED BY THE GEOTECHNICAL ENGINEER. FOOTINGS NOT SUPPORTED BY ENGINEERED FILL SHOULD BEAR ON FIRM UNDISTURBED MATERIAL. EXCAVATIONS FOR FOOTINGS SHALL BE CLEANED AND HAND TAMPED TO A UNIFORM SURFACE.
5. PLACE ALL GRANULAR FILL MATERIAL IN LAYERS NOT EXCEEDING 6 INCHES IN LOOSE THICKNESS. COMPACT ALL GRANULAR FILL BENEATH SLABS ON GRADE AND FOOTINGS TO 98 PERCENT MODIFIED MAXIMUM DRY DENSITY, ASTM D 1557. GRANULAR FILL SHALL BE PLACED AND COMPACTED TO 95 PERCENT MODIFIED MAXIMUM DRY DENSITY, ASTM D1557. MATERIAL PLACEMENT AND COMPACTION USED TO FILL SHALL BE APPROVED BY THE GEOTECHNICAL ENGINEER AND OVERSEEN BY THE TESTING AGENCY.
6. PROTECT THE EXPOSED SUBGRADE IN THE BASIS OF THE FOOTING EXCAVATIONS FROM ANY DETRIMENTAL CHANGE IN CONDITION, SUCH AS DISTURBANCE, DRIVING RAIN OR FREEZING. SURFACE RUNOFF SHALL NOT BE ALLOWED TO ENTER THE EXCAVATIONS. JUST PRIOR TO CONCRETE PLACEMENT, SPRINKLE SURFACE OF FILL TO PROVIDE A SATURATED SURFACE DRY CONDITION.
7. PLACE ALL FOUNDATIONS IN WOOD FORMS.
8. PLACE SLABS ON GRADE ON MIN. 6 INCHES OF PROPERLY COMPACTED, FREE DRAINING GRANULAR MATERIAL, APPROVED BY THE TESTING AGENCY, U.N.O.
9. ALL CONCRETE WALLS RETAINING EARTH (AND ASSOCIATED TOP AND BOTTOM SUPPORTING SLABS) MUST ATTAIN 90 PERCENT OF THE REQUIRED 28 DAY COMPRESSIVE STRENGTH BEFORE BACKFILLING OPERATIONS BEGIN!

10. ALL BACKFILL PLACED AGAINST CONCRETE WALLS SHALL BE A WELL GRADED GRANULAR MATERIAL, APPROVED BY THE GEOTECHNICAL ENGINEER, AND BE PLACED AS INDICATED ON THE STRUCTURAL DRAWINGS.

11. ENGINEERED FILL SHALL BE CLEAN, WELL GRADED AND FREE DRAINING IN ITS COMPACTED STATE. THE MATERIAL SHALL CONFORM TO THE GRADATION REQUIREMENTS OF "B" BORROW SIZE LISTED IN THE INDOT STANDARD SPECIFICATIONS.
12. GRANULAR FILL MATERIAL SHALL BE A "PIT RUN GRAVEL" AS IT OCCURS IN THE NATURAL STATE WITH NO LUMPS OF CLAY OR ROCKS LARGER THAN 2 INCHES IN DIAMETER. IT MUST CONFORM TO THE FOLLOWING GRADATIONS: 10 TO 40 PERCENT SAND, 40 TO 80 PERCENT GRAVEL, AND 0 TO 15 PERCENT CLAY. OBTAIN FROM BORROW PIT APPROVED BY THE OWNER AND THE GEOTECHNICAL ENGINEER.
13. FOUNDATION CONDITIONS NOTED DURING CONSTRUCTION WHICH DIFFER FROM THOSE DESCRIBED IN THE GEOTECHNICAL REPORT SHALL BE REPORTED TO THE STRUCTURAL ENGINEER, AND THE GEOTECHNICAL ENGINEER BEFORE FURTHER CONSTRUCTION IS ATTEMPTED.

1. THE MIXING, HANDLING, PLACING AND CURING OF CONCRETE SHALL BE IN ACCORDANCE WITH THE ACI BUILDING CODE REQUIREMENTS FOR REINFORCED CONCRETE (ACI 318, EDITION AS REFERENCED BY THE CURRENT BUILDING CODE), WITH THE LATEST EDITION OF ACI 301, ACI 308, ACI 318 AND ACI 360. DO NOT PLACE DURING RAIN, SLEET OR SNOW WITHOUT ADEQUATE PROTECTION.
3. WHERE REINFORCING IS INTERRUPTED BY OPENINGS, ONE HALF OF THE INTERRUPTED STEEL SHALL BE ADDED EACH SIDE OF OPENING. IN ADDITION TO REINFORCING SHOWN AT OPENINGS ON THE DRAWINGS.
4. SUBMIT A MIX DESIGN FOR EACH CLASS OF CONCRETE SPECIFIED.
5. PROVIDE ¾" INCH CHAIRS ON ALL EXPOSED CORNERS OF CONCRETE EXCEPT THOSE ABUTTING MASONRY.
6. ALL CONCRETE EXPOSED TO WEATHER SHALL BE AIR ENTRAINED, EXCEPT SLABS WITH A HARD TROWEL FINISH.
7. SEE SECTION 03300, CAST-IN-PLACE CONCRETE, OF THE PROJECT MANUAL FOR ADDITIONAL REQUIREMENTS.
8. ALL BEAMS, SPANDRILS AND SLABS SHALL BE CAST MONOLITHICALLY EXCEPT FOR REINFORCED CONSTRUCTION. CONTRACTOR SHALL SUBMIT ANY AND ALL ALTERNATE AND ADDITIONAL CONSTRUCTION JOINT LOCATIONS AND DETAILS.
9. CONSTRUCTION JOINTS REQUIRED BY THE ENGINEER ARE SHOWN ON THE DRAWINGS. ADDITIONAL CONSTRUCTION JOINTS SHALL BE PROVIDED AS OUTLINED IN SPECIFICATIONS. REINFORCEMENT SHALL BE CONTINUOUS ACROSS CONSTRUCTION JOINTS. SUBMIT ALL CONSTRUCTION JOINT LOCATIONS WITH REINFORCING STEEL SHOP DRAWINGS.
10. PROVIDE WATERSTOPS IN ALL FOUNDATIONS, WATER-RETAINING STRUCTURES AND OTHER STRUCTURES UP TO AND INCLUDING 12 INCHES ABOVE GRADE OR TO AN ELEVATION AT LEAST 12 INCHES ABOVE LIQUID LEVEL IN WATER-RETAINING STRUCTURES, WHICHEVER IS HIGHER, WHETHER SHOWN OR NOT.

11. WELDING OF REINFORCING STEEL IS NOT PERMITTED.
12. CALCULUM CHLORIDE SHALL NOT BE PERMITTED NOR SHALL ANY ADMIXTURE CONTAINING CALCIUM CHLORIDE BE PERMITTED THAT RESULTS IN A TOTAL CONCRETE MIX IN WHICH THE PRESENCE OF CHLORIDES EXCEEDS 0.15 PERCENT BY WEIGHT OF CEMENT.
13. ALUMINUM PIPE SHALL NOT BE USED WITH CONCRETE PUMPS.
14. CONCRETE SHALL BE DISCHARGED AT THE SITE WITHIN 90 MINUTES AFTER WATER HAS BEEN ADDED TO THE CEMENT AND AGGREGATES. ADDITION OF WATER TO THE MIX AT THE PROJECT SITE WILL NOT BE ALLOWED. ALL WATER MUST BE ADDED AT THE BATCH PLANT.
15. REINFORCING BARS REQUIRED FOR PROPER SUPPORT OF PRINCIPAL MEMBERS SHALL BE DETAIL AND NOTED ON THE DRAWINGS.

16. POSITIVE CONNECTION SPLICES; MECHANICAL CONNECTIONS SHALL DEVELOP 125 PERCENT OF THE YIELD STRENGTH OF THE REINFORCING BAR. ALL SPLICES WILL BE VISUALLY INSPECTED BY THE ENGINEER TO VERIFY THAT THE SPLICE HAS BEEN MADE PROPERLY.

CONCRETE SCHEDULE		
CONCRETE CLASS	COMPRESSIVE STRENGTH	AIR CONTENT
A1	4000 PSI	6 +/- 1%
B1	5000 PSI	6 +/- 1%

1. ALL REINFORCING STEEL BARS, HOOKS, LAP SPLICES AND MINIMUM CONCRETE COVER SHALL CONFORM TO THE ACI BUILDING CODE REQUIREMENTS AND REINFORCED CONCRETE (ACI 318 AND ACI 360, EDITION AS REFERENCED BY THE CURRENT BUILDING CODE), UNLESS OTHERWISE INDICATED.
2. SLAB BOLSTERS, HIGH CHAIRS, BEAM BOLSTERS AND ALL OTHER ACCESSORIES IN CONTACT WITH THE FORMS FOR EXPOSED CONCRETE, BOTH INTERIOR AND EXTERIOR, SHALL BE PLASTIC TYPED. SUCH ACCESSORIES SHALL HAVE TURNED-UP LEES.

3. ALL REINFORCED STEEL SHALL BE SUPPORTED AND SECURED AGAINST DISPLACEMENT IN ACCORDANCE WITH THE CONCRETE REINFORCING STEEL INSTITUTES' MANUAL OF STANDARD PRACTICE, LATEST EDITION. OVERLAPPING TALLS SHALL BE SUPPORTED POSITIVELY. USE ONLY #6 BARS WITH INDIVIDUAL HIGH CHAIRS FOR SUPPORT OF TOP SLAB BARS. EACH SUPPORT OF PROPER LENGTH, MAY REPLACE A TEMPERATURE BAR IN THE PARALLEL DIRECTION. SHOW SLAB BAR SUPPORTS ON SHOP DRAWINGS.
4. DETAILS OF FABRICATION AND PLACING OF REINFORCEMENT NOT SHOWN ON THESE PLANS SHALL FOLLOW THE CURRENT EDITION OF THE MANUAL OF STANDARD PRACTICE FOR DETAILING REINFORCED CONCRETE STRUCTURES, LATEST EDITION, AS ADOPTED BY THE AMERICAN CONCRETE INSTITUTE. ANCHOR ALL TOP BARS EITHER BY STANDARD EMBEDMENT OR BY 90-DEGREE HOOKS, UNLESS OTHERWISE INDICATED.

5. ALL CONCRETE REINFORCEMENT MATERIALS SHALL BE NEW, FREE FROM RUST AND ANY SUBSTANCE THAT WOULD PREVENT BONDING OF THE CONCRETE TO THE STEEL, AND COMPLY WITH THE FOLLOWING REFERENCE STANDARDS:
ALL REINFORCING BARS (EXCEPT AS NOTED BELOW) ASTM A615, GRADE 60
STIRRUPS AND COLLUMN BARS: ASTM A482
WELDED WIRE FABRIC: ASTM A-185

6. ALL REINFORCING STEEL SHALL BE NEW BILLET STEEL, FREE FROM RUST AND CONFORMING TO ASTM A615, GRADE 60.
7. THE SHOP DRAWINGS FOR REINFORCING STEEL SHALL INCLUDE "X" SCALE ELEVATIONS OF ALL CONCRETE WALLS AND BEAMS AND ALL SECTIONS REQUIRED FOR REINFORCING STEEL FABRICATION AND PLACEMENT SHALL CONFORM TO ALL DETAILS AND DETAILING OF CONCRETE REINFORCEMENT (ACI 318), LATEST EDITION, AND MANUAL OF ENGINEERING AND PLACING DRAWINGS FOR REINFORCED CONCRETE STRUCTURES (ACI 318R), LATEST EDITION, UNLESS OTHERWISE INDICATED.
8. CONCRETE REINFORCING SHALL HAVE THE FOLLOWING PROTECTION:
CONCRETE PLACED AGAINST EARTH _____ 3"
MAT OR SLAB BEING TO CLEAR WATERSTOP _____ 3"
CONCRETE CAST AGAINST FORMS (LEFT IN PLACE) _____ 2"

- CONCRETE PLACED IN FORMS BUT EXPOSED TO FLUIDS, WEATHER OR IN CONTACT WITH THE GROUND: _____ 2"
WALL _____ 2" (#6 BARS AND SMALLER),
_____ 2" (#8 BARS AND LARGER)
- CONCRETE NOT EXPOSED TO FLUIDS, WEATHER OR IN CONTACT WITH THE GROUND: _____ 1 1/2"
WALLS _____ 1 1/2"
BEAMS, COLUMNS (STIRRUPS, TIES, SPIRALS) _____ 1 1/2"

9. SET DOWELS AND COLUMN OR PIER MAIN BARS, WHICH EXTEND ABOVE CONSTRUCTION JOINTS, TO WOOD POSITIONING TEMPLATES AT TOP OF INTENDED CONCRETE PLACEMENT LEVEL. BRACE AGAINST DISPLACEMENT. SETS EMBEDTED TIES, SUCH AS STEEL COLUMN ANCHOR BOLTS, USING WOOD POSITIONING TEMPLATES AND BRACE AGAINST DISPLACEMENT.
10. SPREAD REINFORCING STEEL AROUND SMALL OPENINGS AND SLEEVES IN SLABS AND WALLS WHERE POSSIBLE, AND DISCONTINUE BARS AT OPENINGS WHERE TIES THE NORMAL SPACING. DISCONTINUE BARS AT OPENINGS WHERE NECESSARY AND PROVIDE AN AREA OF REINFORCEMENT EQUAL TO THE INTERRUPTED REINFORCEMENT, IN FULL LENGTH BARS, DISTRIBUTING ONE-HALF EACH SIDE OF THE OPENING, WHERE TEMPERATURE REINFORCING IS INTERRUPTED. ADD (2) #6 X (OPENING DIMENSION + 4) IN ON EACH FACE OF ALL SLEEVES IF THE OPENING, PROVIDE (2) #6 X (2) INCHES IN BOTH FACES AT EACH CORNER OF OPENINGS LARGER THAN 12 INCHES IN ANY DIRECTION. BEND TIES AS INDICATED. SEE TYPICAL REINFORCING AT CONCRETE WALL OPENINGS DETAIL.

11. WORK IN THIS SECTION INCLUDES BAR GRATING, STEEL STAIRS, RAILINGS, PIPE GUARD POSTS AND ACCESSORIES NEEDED TO COMPLETE THE INSTALLATION.
12. ALL WORK IN THIS SECTION SHALL COMPLY WITH THE ADMINISTRATIVE BUILDING COUNCIL OF INDIANA CONSTRUCTION RULES AND REGULATIONS, THE ASCE "SPECIFICATION FOR DESIGN, FABRICATION AND ERECTION OF STRUCTURAL STEEL FOR BUILDINGS", THE ASCE CODE OF STANDARD PRACTICE FOR BUILDINGS AND BRIGDES, AND THE AMERICAN IRON AND STEEL INSTITUTES "SPECIFICATIONS FOR THE DESIGN OF COIL-FORMED STEEL STRUCTURAL MEMBERS", EDITIONS AS REFERENCED BY THE CURRENT BUILDING CODE, IN THE ABSENCE OF A BUILDING CODE REFERENCE USE THE LATEST EDITION.

13. MATERIALS:
STEEL BARS AND PLATES: _____ ASTM A36
ANCHOR BOLTS: _____ SECTIONS 1, 3 OF ASTM A307
STEEL PIPE: _____ ASTM A23-40, GRADE B
14. BOLTED CONNECTIONS SHALL BE BEARING-TYPE CONNECTIONS, USING ¾" INCH DIAMETER A325 BOLTS WITH STANDARD, 13/16 INCH DIAMETER HOLES, UNLESS OTHERWISE DETAILED ON THE STRUCTURAL DRAWINGS.
15. BURNING OF HOLES IN MISCELLANEOUS STEEL SHALL NOT BE ALLOWED.

16. SHOP PAINT METAL EXCEPT STEEL, ENCASED IN CONCRETE STAINLESS STEEL, ALUMINUM AND GALVANIZED STEEL. ALL STEEL TO BE SHOP PAINTED SHALL RECEIVE SURFACE PREPARATION AND ONE SHOP COAT OF PRIMER. THE DRY FILM THICKNESS SHALL NOT BE LESS THAN 2.0 MILS. APPLICATION SHALL BE IN ACCORDANCE WITH THE MANUFACTURER'S RECOMMENDATIONS. SEE SECTIONS 05500, MISCELLANEOUS STEEL, STEEL SHOP PAINTING REQUIREMENTS, AND 05900-SPECIAL COATINGS OF THE PROJECT MANUAL FOR ADDITIONAL PAINT REQUIREMENTS.
17. THE ERECTOR SHALL SPOT PAINT, IN THE FIELD, ALL ABRASIONS TO THE SHOP COAT, BOLTS, AND FIELD WELDS USING THE SAME AS PRIMER AND FINISH COAT. WELDING, BOTH SHOP AND FIELD SHALL BE ACCOMPLISHED BY WELDERS CERTIFIED FOR THE WELD TYPES AND POSITIONS INVOLVED ACCORDING TO AWS D1.1, LATEST EDITION. USE ONLY SHIELDED ARC ELECTRODES OF STRUCTURAL TYPE, USE E-70 ELECTRODES.

ALUMINIUM

1. ALL ALUMINIUM SHALL BE NEW AND CONFORM TO THE APPLICABLE ASTM SPECIFICATIONS AS REGISTERED WITH "THE ALUMINIUM ASSOCIATION" FOR THE AFOY LISTED BELOW:
A. STRUCTURAL SHAPES AND PLATE ALLOY 6061-T6
B. WELDING FILLER METAL ALLOY 5356
C. BOLTS - STAINLESS STEEL TYPE A316 OR 316
D. ANCHOR BOLTS - STAINLESS STEEL, A316 TYPE 304 OR 316
E. EXPANSION BOLTS - STAINLESS STEEL, A316 TYPE 304 OR 316

2. SHOP CONNECTIONS SHALL BE BOLTED OR WELDED.
3. FIELD CONNECTIONS SHALL BE BOLTED. FIELD WELDING SHALL NOT BE PERMITTED UNLESS SO NOTED ON THE CONTRACT DRAWINGS.
4. BRACING SHALL HAVE A MINIMUM OF TWO BOLTS PER CONNECTION UNLESS NOTED.
5. ALL BOLTS SHALL BE ¾" DIA. MIN. UNLESS OTHERWISE NOTED ON CONTRACT DRAWINGS.
6. BEAM CONNECTION SHALL BE PROVIDED TO SUPPORT THE TOTAL ALLOWABLE UNIFORM LOAD CAPACITY OF THE BEAM FOR THE SPAN AND ALLOY INDICATED.
7. MATERIALS: BACK PAINT ALUMINIUM AS PER PAINT SPECIFICATIONS.

1. GROUT SHALL BE A PREMIXED, NON-METALLIC, SHRINKAGE RESISTANT (WHEN TESTED IN ACCORDANCE WITH THE LATEST EDITION OF ASTM C827 OR C827-1) SOLID GROUT. THE MIX DESIGN SHALL BE PROVIDED TO THE CONTRACTOR. ALL PLASTICIZING ADDITIVES GROUT SHALL HAVE A MINIMUM COMPRESSIVE STRENGTH (F_{CD}) OF 7,000 PSF AT 28 DAYS.
2. GROUT COMPRESSIVE STRENGTH TESTS SHALL BE PERFORMED IN ACCORDANCE WITH THE LATEST EDITION OF ASTM C109.

REINFORCEMENT LAP SPLICE, EMBEDMENT LENGTH AND STANDARD HOOKS

BAR SIZE	MIN LAP LENGTHS FOR CLASS B		MIN EMBEDMENT LENGTHS FOR BEAMS AND COLUMNS *		FOR SLABS **		WITH STD. HOOKS	
	TOP***	OTHERS	TOP***	OTHERS	TOP***	OTHERS	A OR G	A OR G
#3	25	19	16	19	15	12	5	6
#4	33	25	20	16	25	19	15	8
#5	41	31	30	23	37	30	24	12
#6	49	37	37	30	44	37	30	15
#7	57	44	44	37	52	44	37	18
#8	65	51	51	44	60	51	44	21
#9	73	59	59	51	68	59	51	24
#10	81	67	67	59	76	67	59	27
#11	89	75	75	67	84	75	67	30
#14	114	87	87	84	109	87	84	36

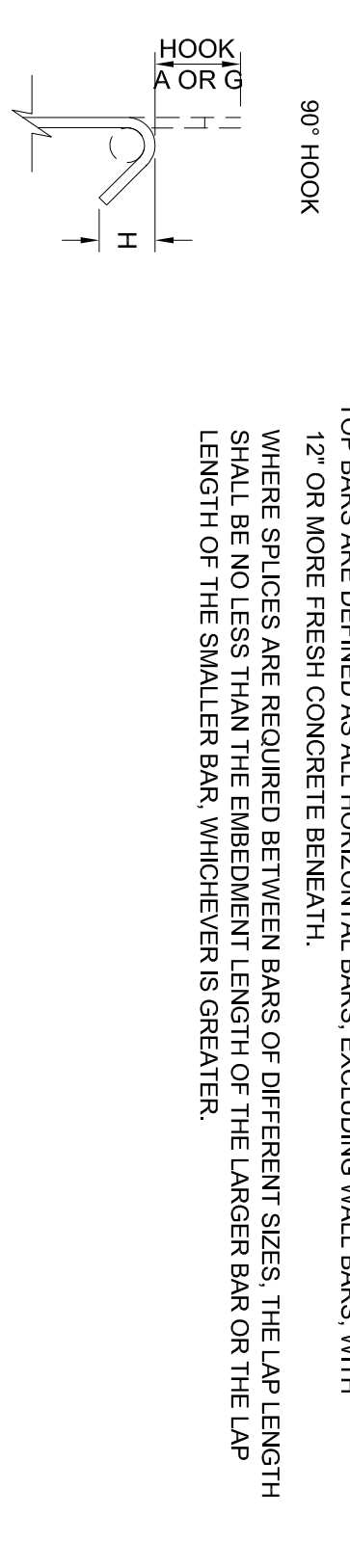
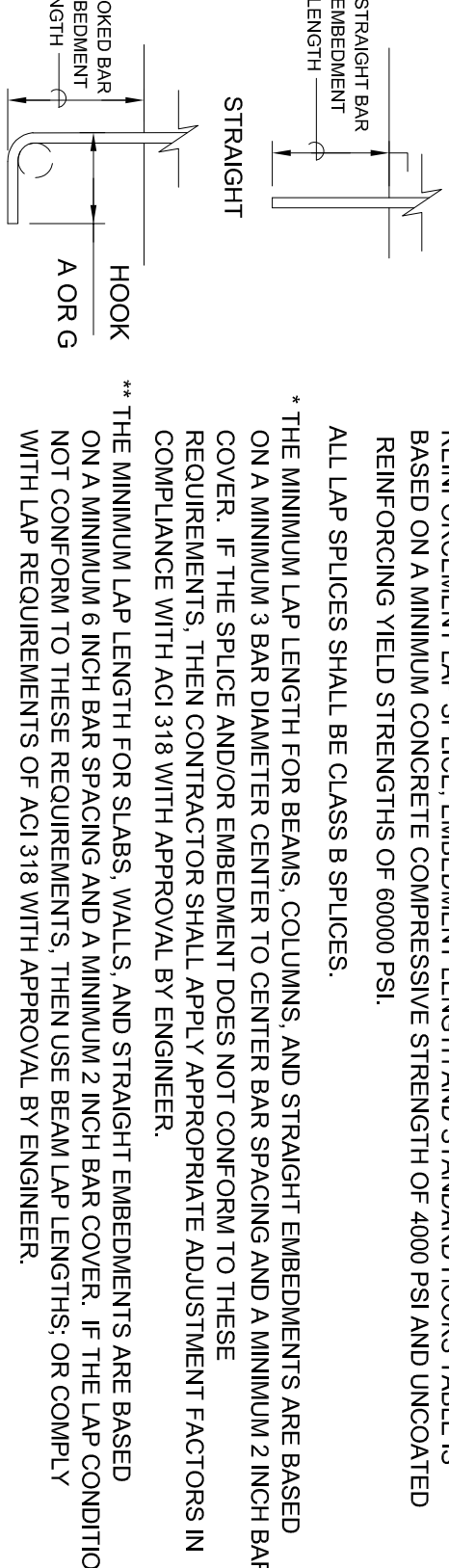

LAP SPLICE AND EMBEDMENT LENGTH TABLE

*** TOP BARS ARE DEFINED AS ALL HORIZONTAL BARS EXCLUDING WALL BARS WITH 12" OR MORE FRESH CONCRETE BENEATH.
WHERE SPLICES ARE REQUIRED BETWEEN BARS OF DIFFERENT SIZES, THE LAP LENGTH SHALL BE NO LESS THAN THE EMBEDMENT LENGTH OF THE LARGER BAR OR THE LAP LENGTH OF THE SMALLER BAR, WHICHEVER IS GREATER.

** THE MINIMUM LAP LENGTH FOR SLABS, WALLS, AND STRAIGHT EMBEDMENTS ARE BASED ON A MINIMUM 6 INCH BAR SPACING AND A MINIMUM 2 INCH BAR COVER. IF THE BAR CONDITION DOES NOT CONFORM TO THESE REQUIREMENTS, THEN USE BEAM LAP LENGTHS, OR COMPLY WITH LAP REQUIREMENTS OF ACI 318 WITH APPROVAL BY ENGINEER.

REVISIONS	
DATE	BY

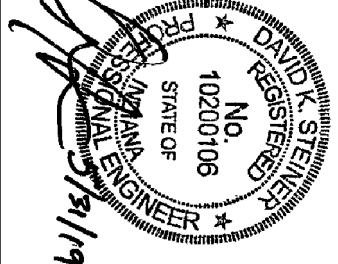

RECOMMENDED FOR APPROVAL	DAVE STEINER	5/31/19
DESIGNED:	DKS	DATE
CHECKED:	DKS	CHECKED: DKS

WHITE RIVER WELL #3	CEG PROJECT NUMBER
VOC REMOVAL	20WR0257
STRUCTURAL GENERAL NOTES	CONSULTANT PROJECT NUMBER
	201800344
	SHEET
	S-0

REVISIONS	
DATE	BY

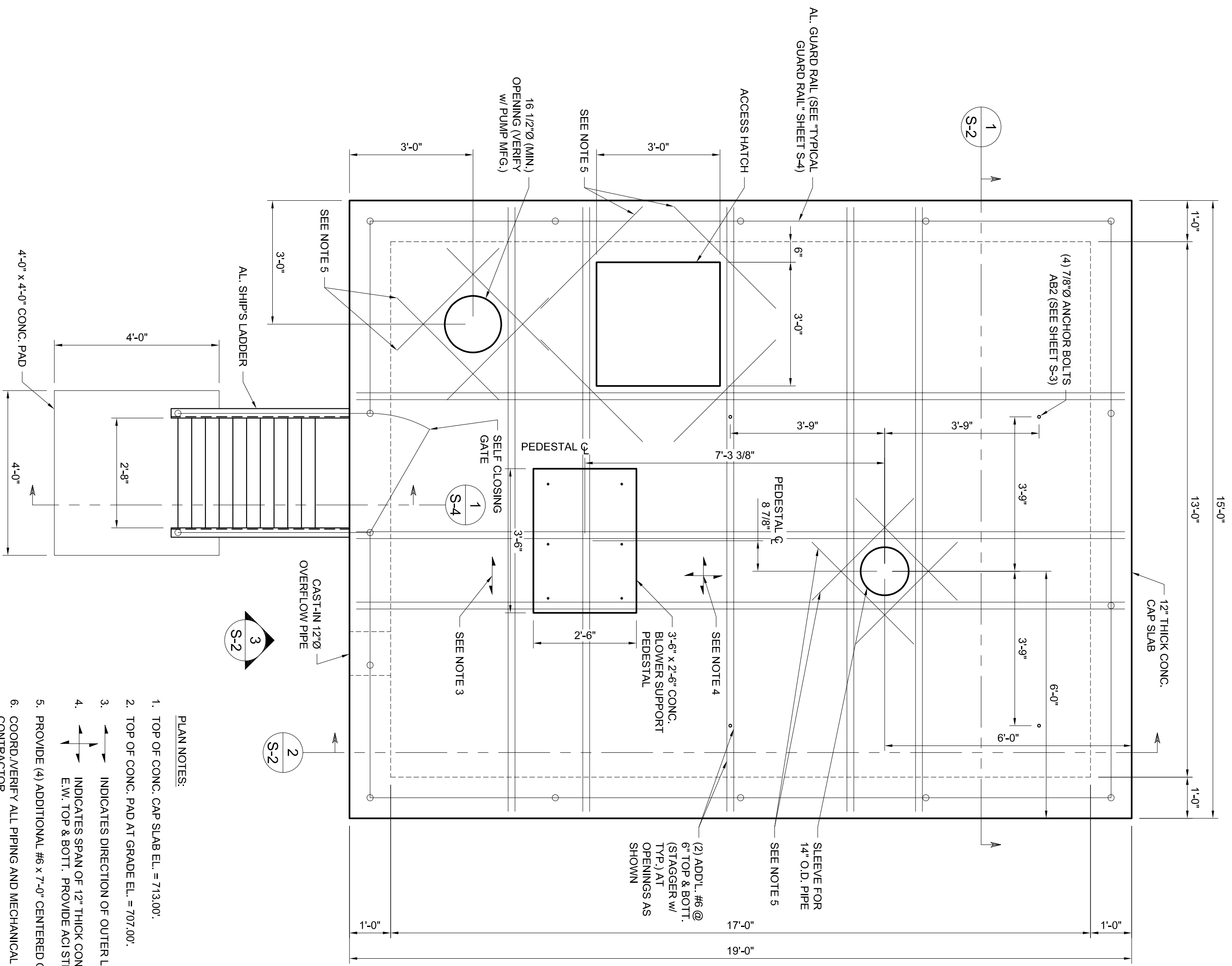

- PLAN NOTES:**
1. TOP OF CONC. CAP SLAB EL. = 713.00'
 2. TOP OF CONC. PAD AT GRADE EL. = 707.00'
 3. INDICATES DIRECTION OF OUTER LAYERS OF REINFORCING TOP & BOT.
 4. INDICATES SPAN OF 12" THICK CONC. SLAB REINFORCED W/ #6 @ 12" O.C. E.W. TOP & BOT. PROVIDE ACI STD. 90° HOOKS EA. END.
 5. PROVIDE (4) ADDITIONAL #6 x 7'-0" CENTERED ON OPENING CORNERS.
 6. COORD./VERIFY ALL PIPING AND MECHANICAL PENETRATIONS W/ MECHANICAL CONTRACTOR.

**AERATION CHAMBER
CAP PLAN**

SCALE: 1/2" = 1'-0"

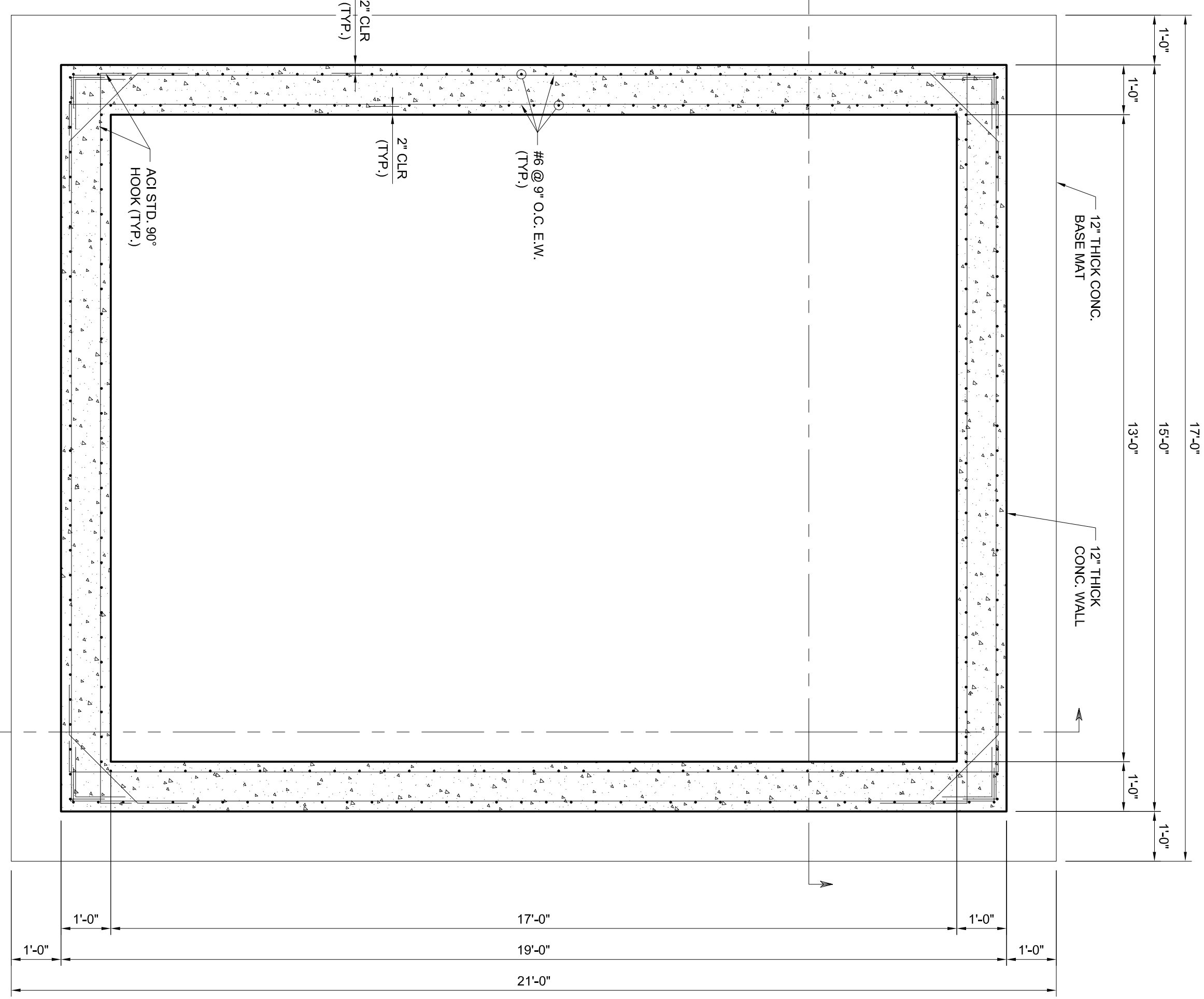
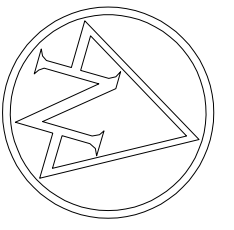

**AERATION CHAMBER
UPPER PLAN**

SCALE: 1/2" = 1'-0"

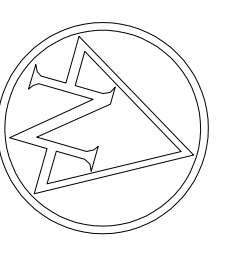

GMID
Geotechnical & Structural Engineering
1402 N. Central Ave.
Suite 200
Indianapolis, IN 46202
Phone (317) 917-4234
Fax (317) 917-4235

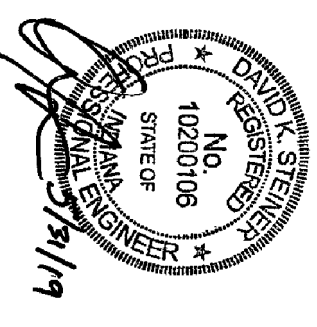

RECOMMENDED FOR APPROVAL	DAVE STEINER	5/31/19
DESIGNED:	DKS	DATE
CHECKED:	DKS	CHECKED:
	DRAWN: JAS	
	CHECKED: DKS	

**WHITE RIVER WELL #3
VOC REMOVAL**

AERATION CHAMBER PLANS

CEG PROJECT NUMBER	20WR02557
CONSULTANT PROJECT NUMBER	201800344
SHEET	S-1

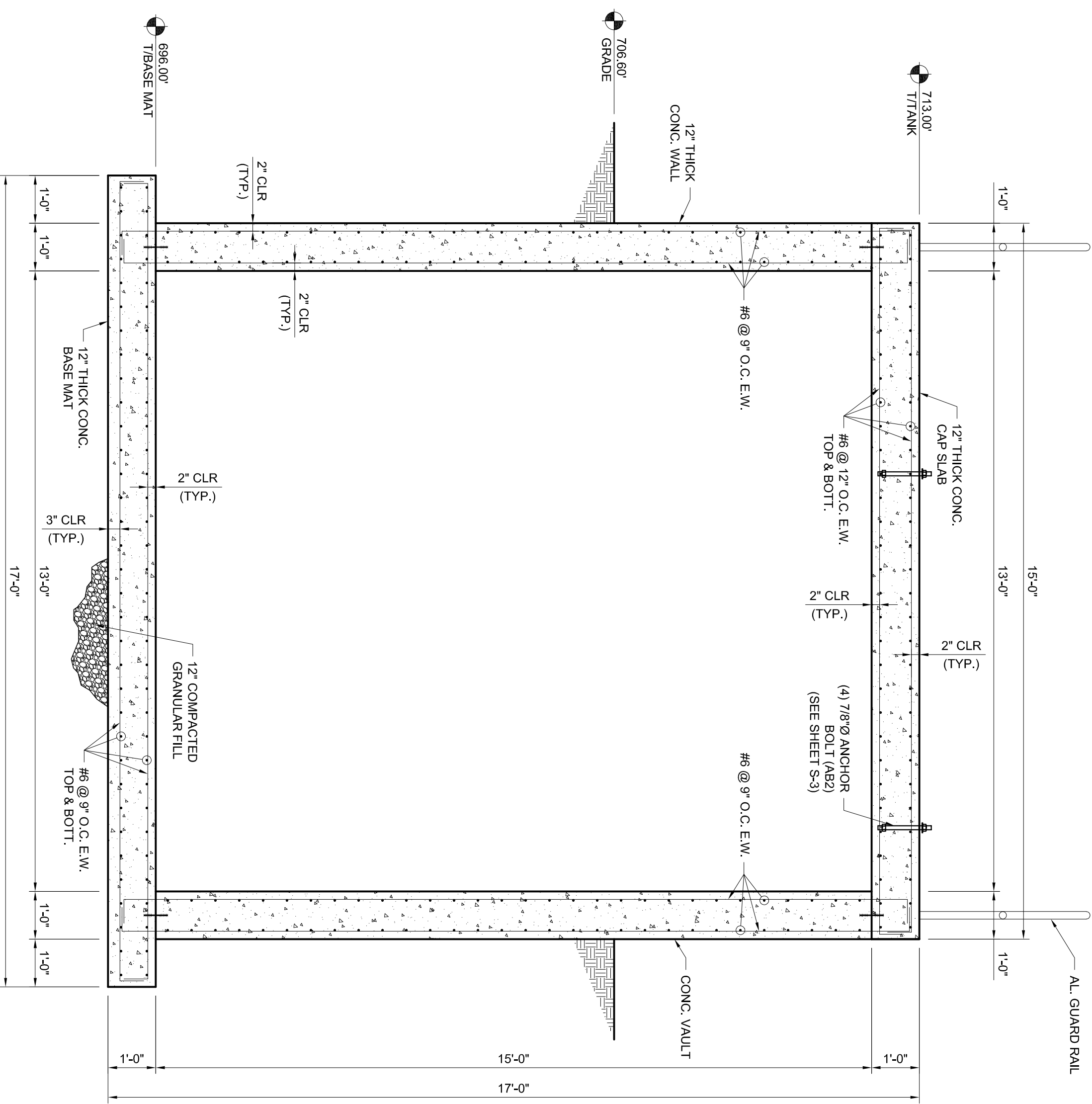

SECTION 1
SCALE: 1/2" = 1'-0"

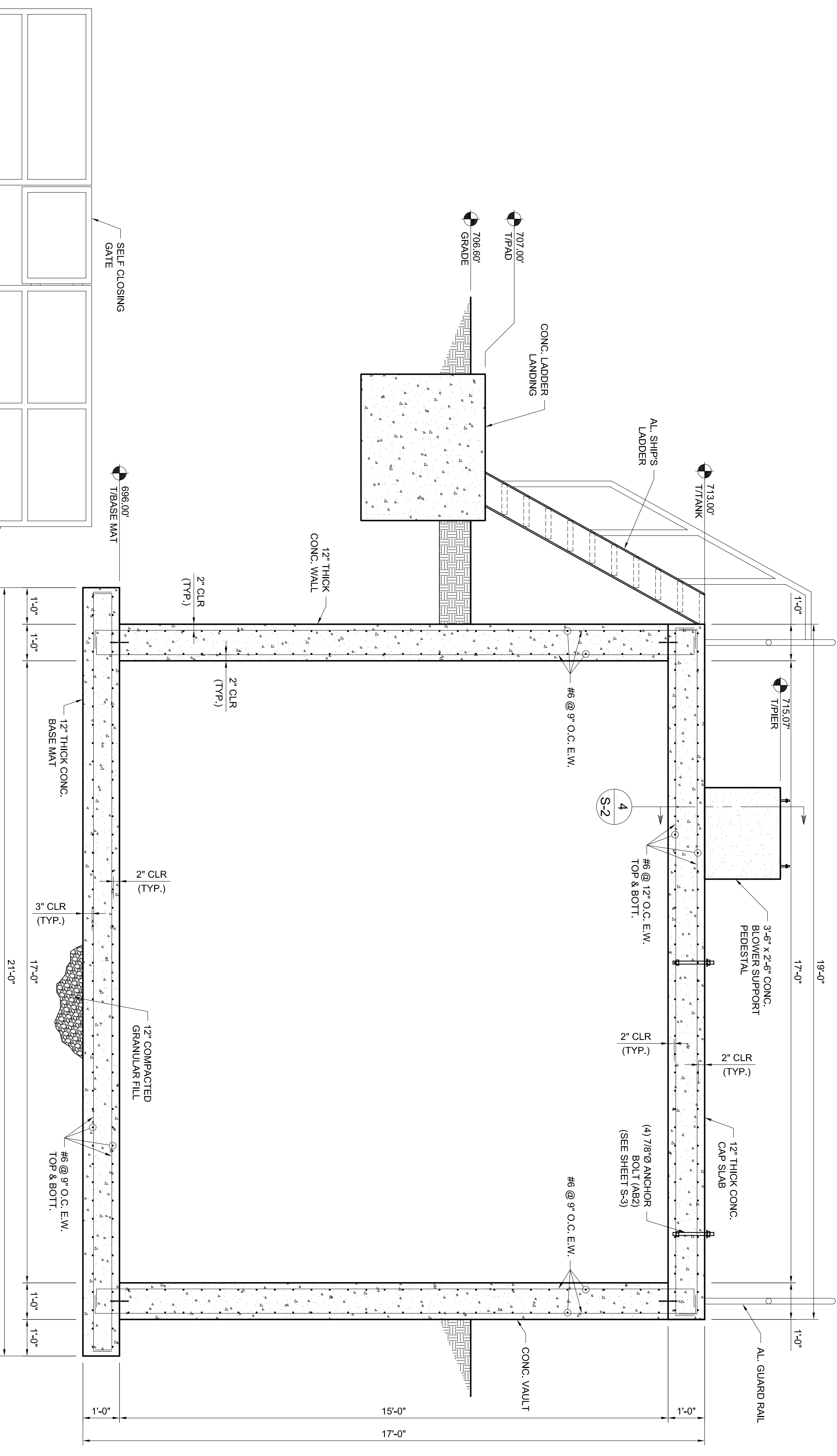

SECTION 2
SCALE: 1/2" = 1'-0"

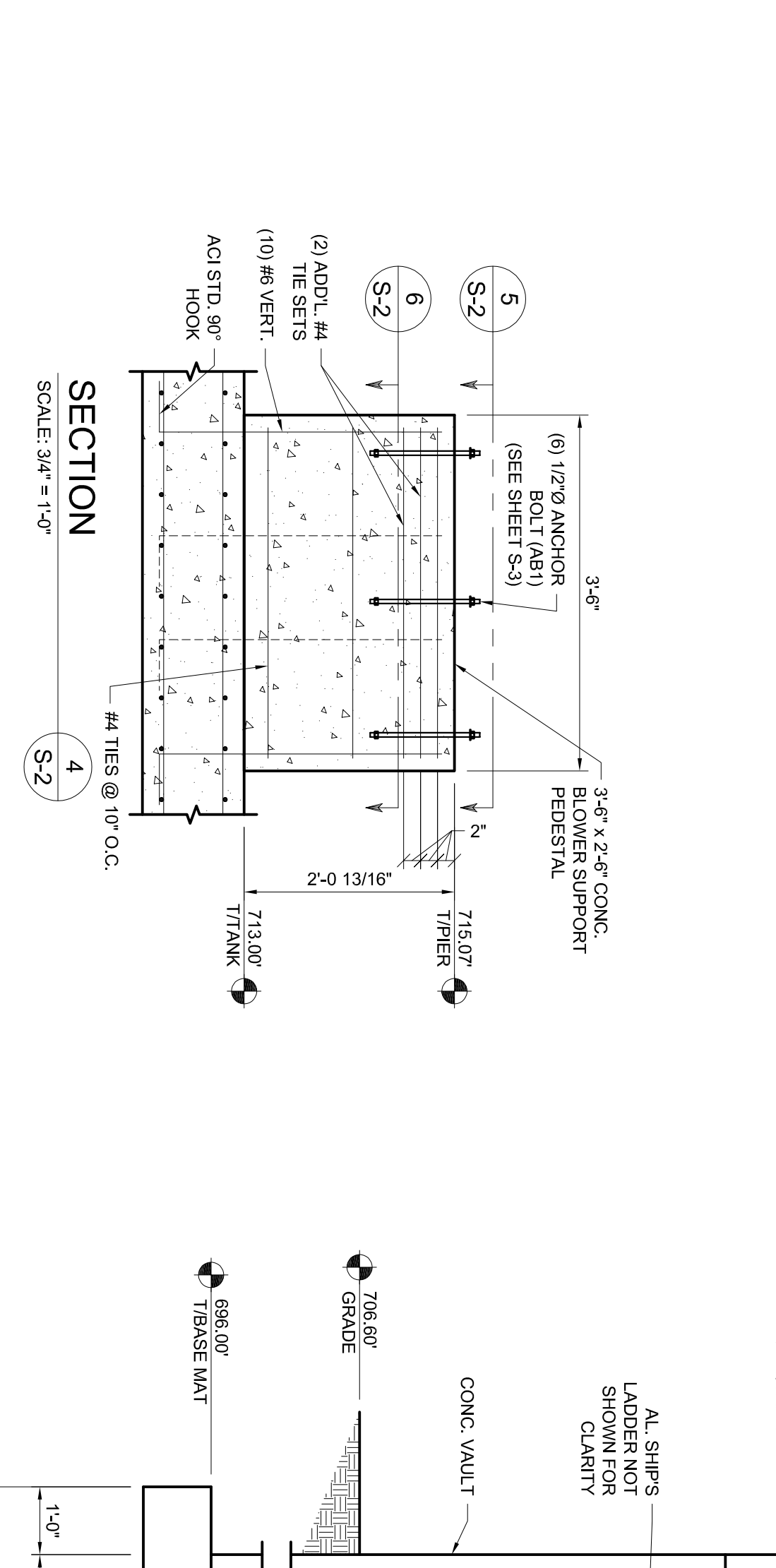

SECTION 3
SCALE: 3/4" = 1'-0"

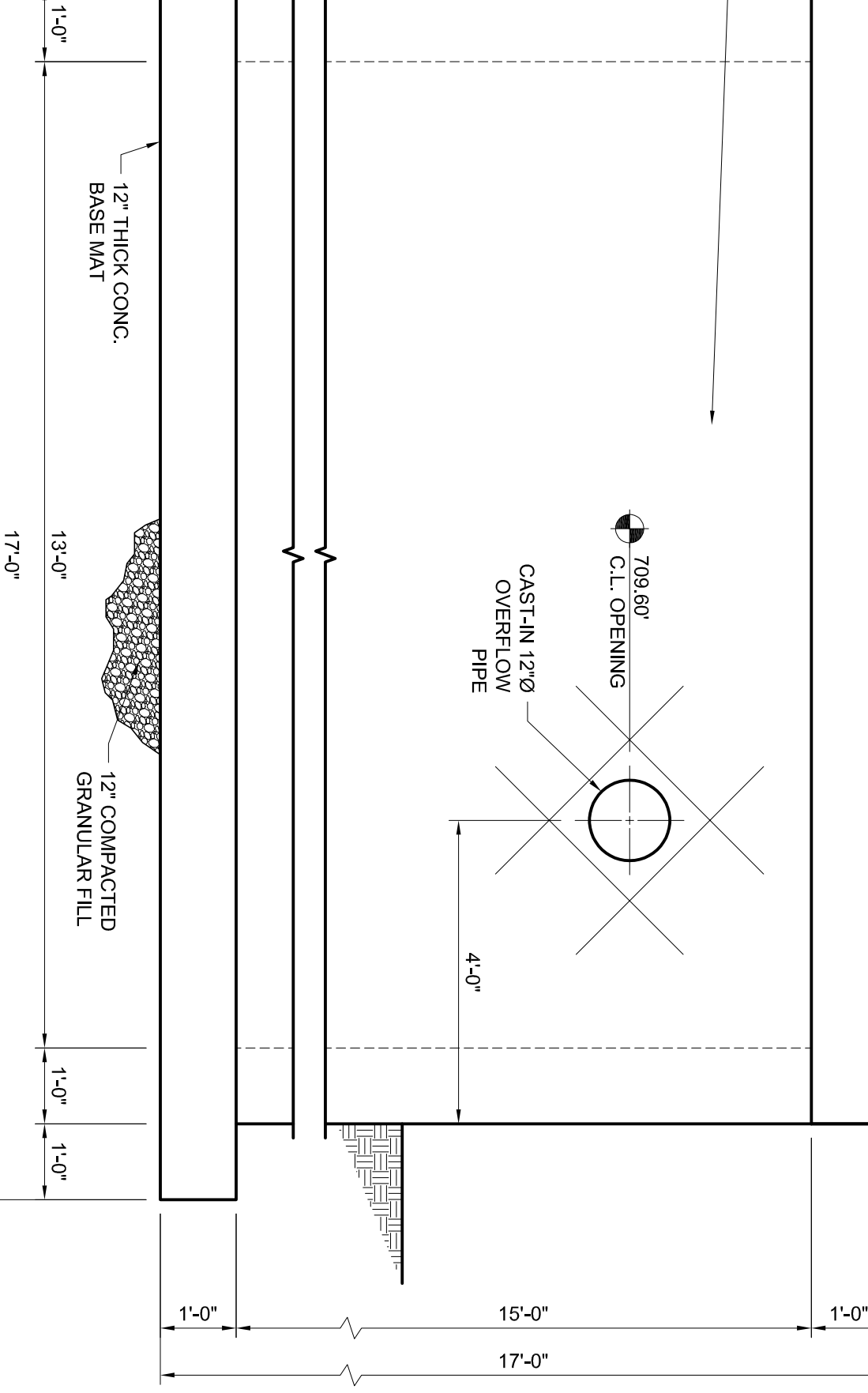

ELEVATION 3
SCALE: 1/2" = 1'-0"

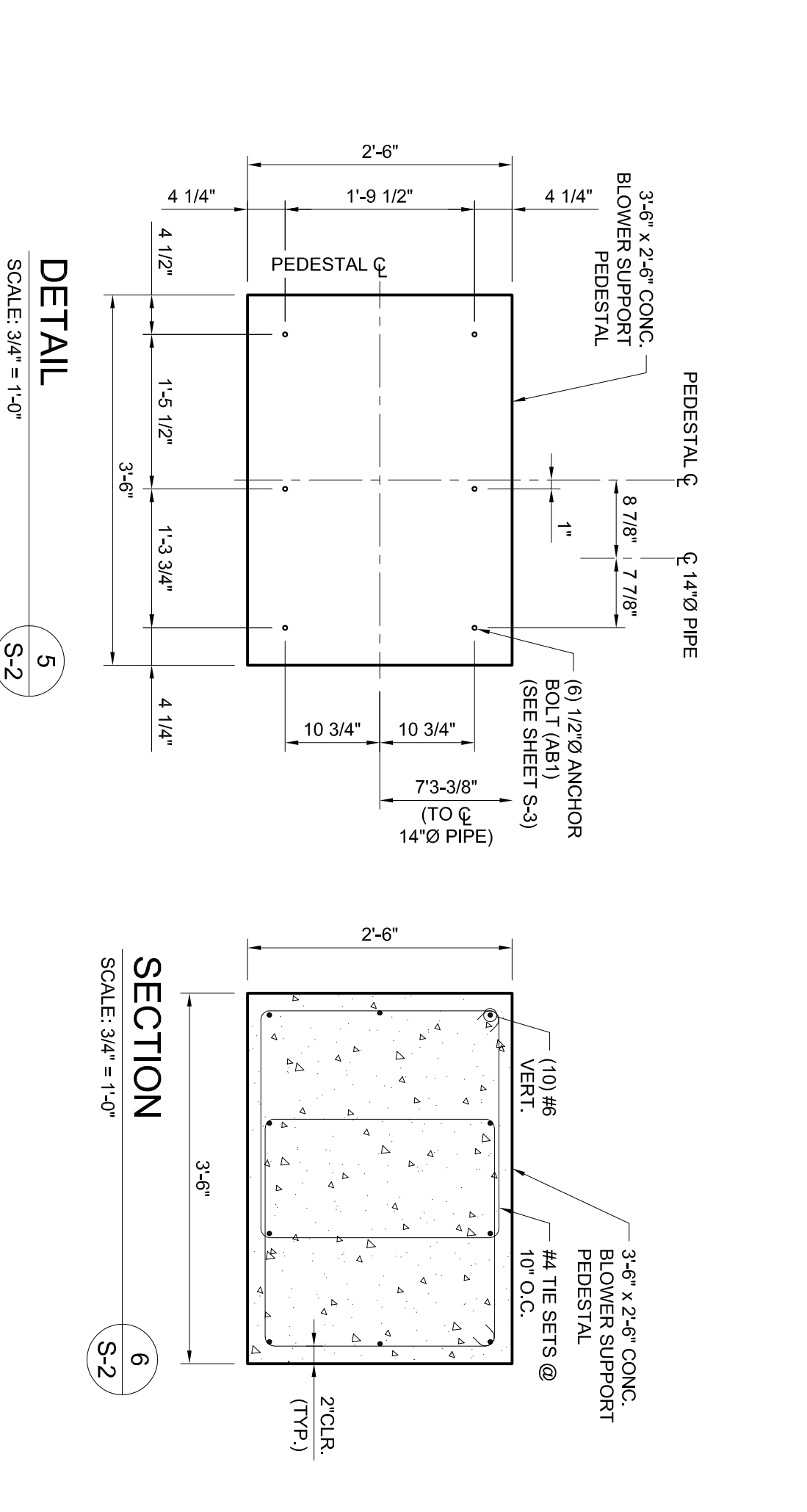

SECTION 4
SCALE: 3/4" = 1'-0"

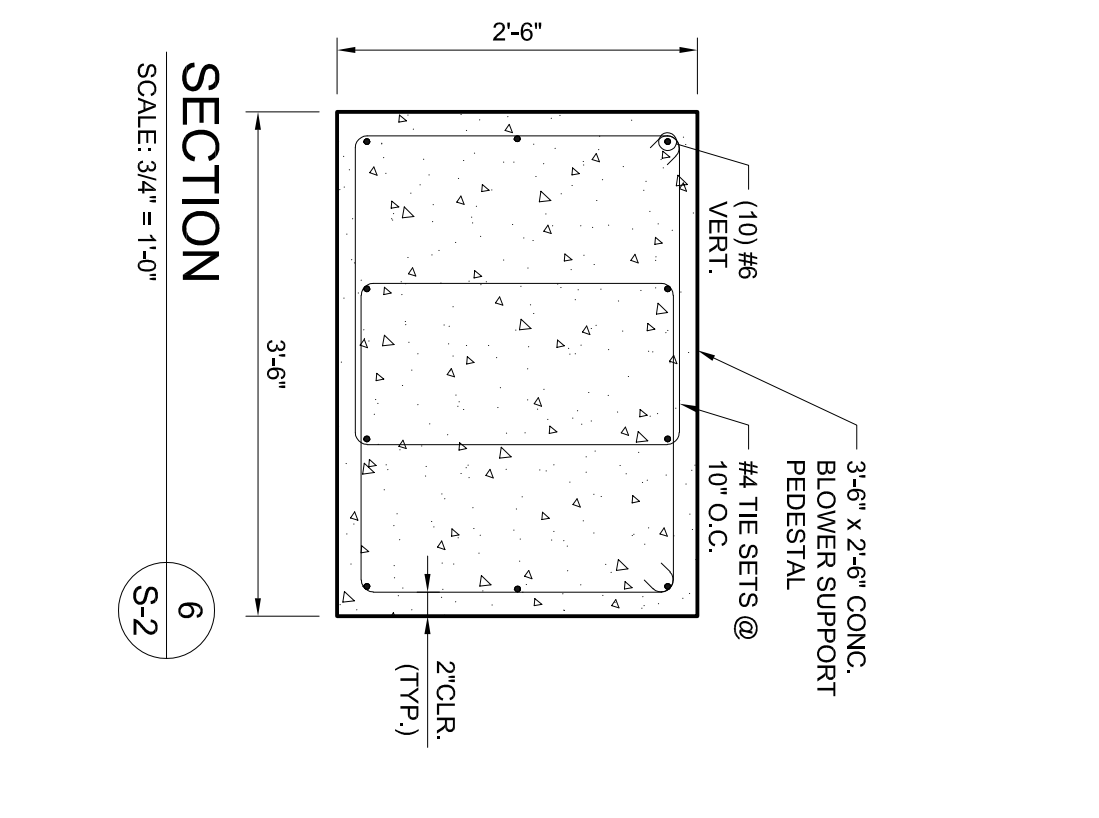

SECTION 5
SCALE: 3/4" = 1'-0"



SECTION 6
SCALE: 3/4" = 1'-0"

DATE	REVISION	BY

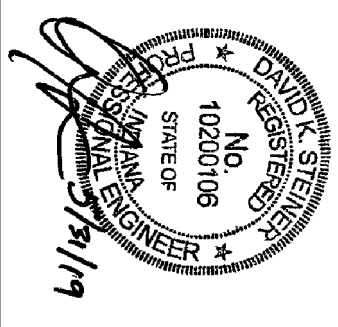

RECOMMENDED FOR APPROVAL	DAVE STEINER	5/31/19
DESIGNED:	DKS	DATE
CHECKED:	DKS	CHECKED:
DRAWN:	JAS	CHECKED:
CHECKED:	DKS	CHECKED:

WHITE RIVER WELL #3
AERATION CHAMBER SECTIONS AND ELEVATION

CEG PROJECT NUMBER	20WR02557
CONSULTANT PROJECT NUMBER	201800344
SHEET	S-2

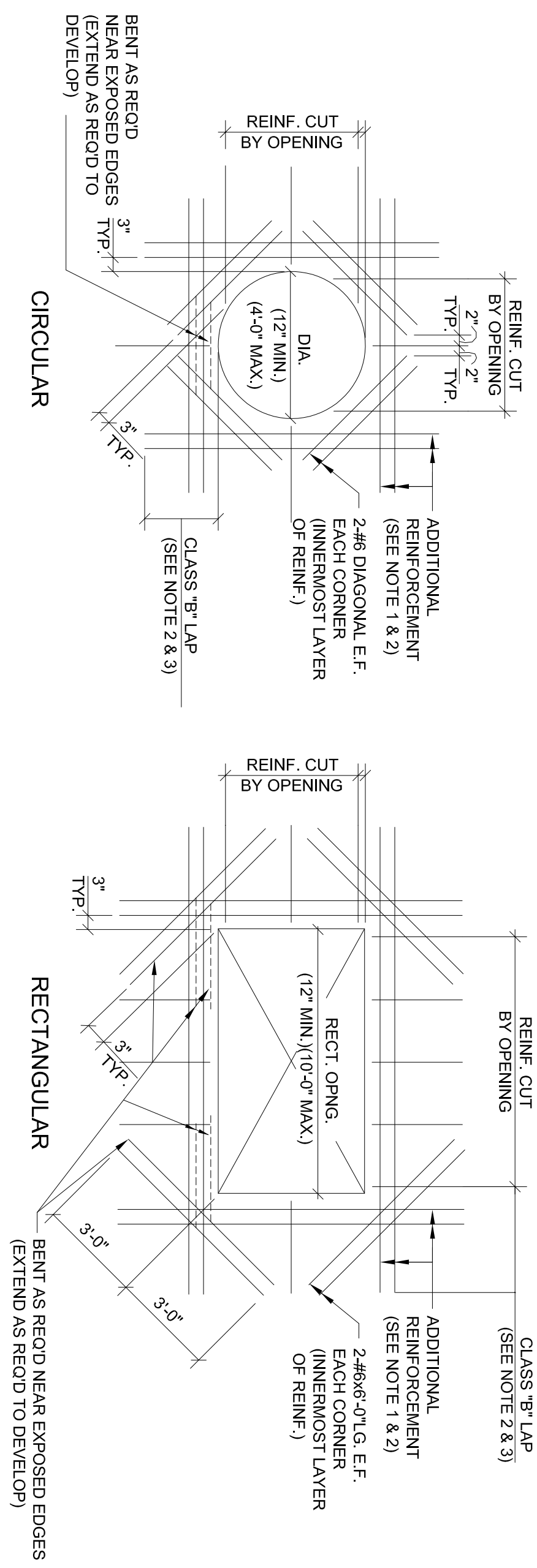

- NOTES:**
- PROVIDE ADDITIONAL REINFORCEMENT AT ALL OPENINGS, ACCESS HATCHES, PIPE PENETRATIONS, ETC. EQUAL IN AREA TO TYPICAL REINFORCEMENT CUT BY OPENING IN EACH DIRECTION. ADDITIONAL REINFORCEMENT TO MATCH SIZE OF TYPICAL REINFORCEMENT (MIN. 2 BARS E9 AND E9) AND PLACED BETWEEN TYPICAL REINFORCEMENT @ 8" SPACING ON EACH SIDE OF OPENING
 - PROVIDE MATCHING DOWELS WHERE REQUIRED TO PROVIDE CLASS 'B' LAP WITH ADDITIONAL REINFORCEMENT. (WHERE LAPPING OF ADDITIONAL REINFORCEMENT FROM ADJACENT OPENINGS OCCUR, ADDITIONAL REINFORCEMENT SHALL BE COMBINED).
 - IF A WALL OR BEAM IS IMMEDIATELY ADJACENT TO THE OPENING, THE ADDITIONAL REINFORCEMENT ON THAT SIDE OF THE OPENING CAN BE OMITTED.

TYPICAL REINFORCING AROUND OPENING IN WALL AND SLAB

1
S-3

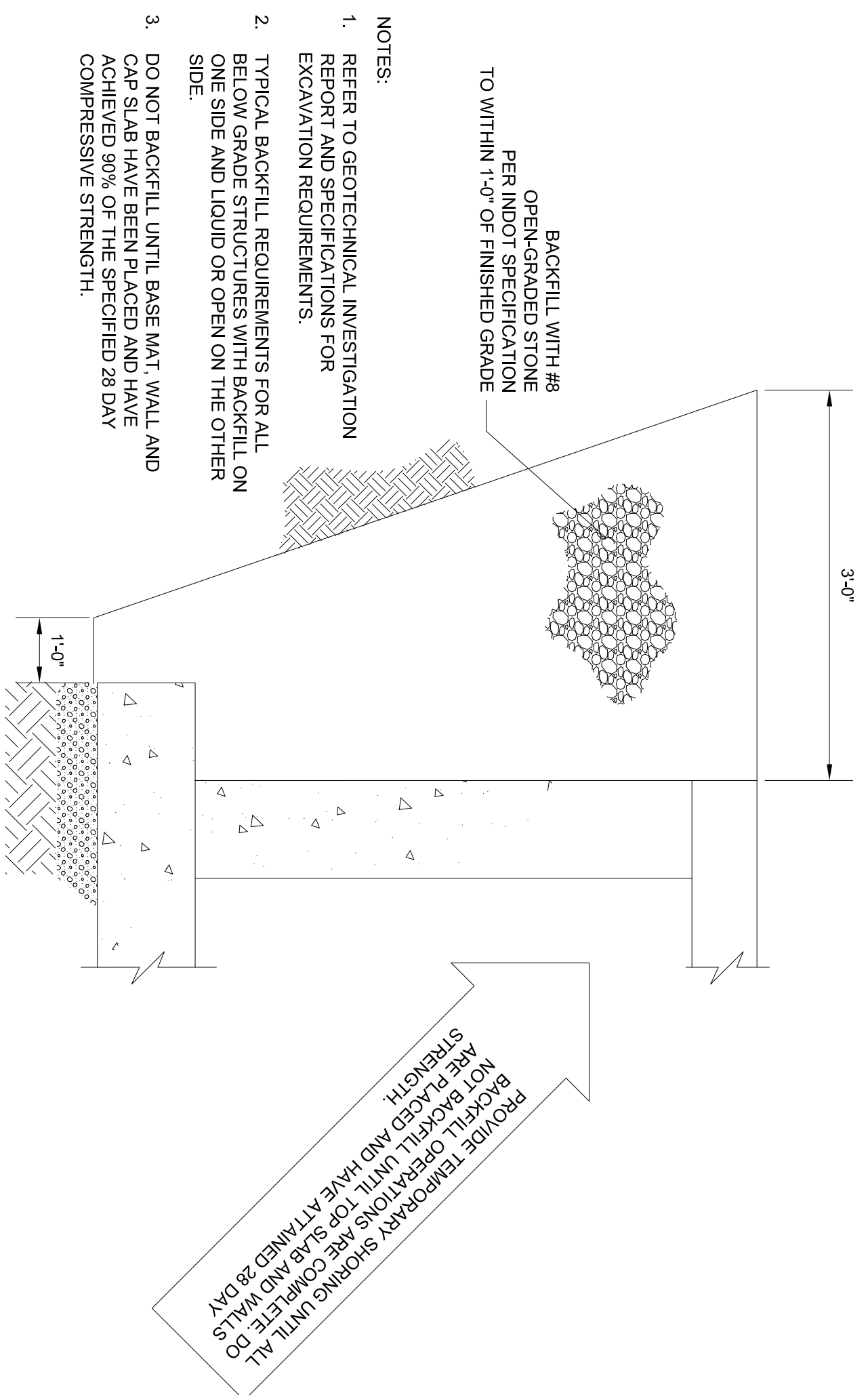

TYPICAL CONCRETE WALL BACKFILL DETAIL

2
S-3

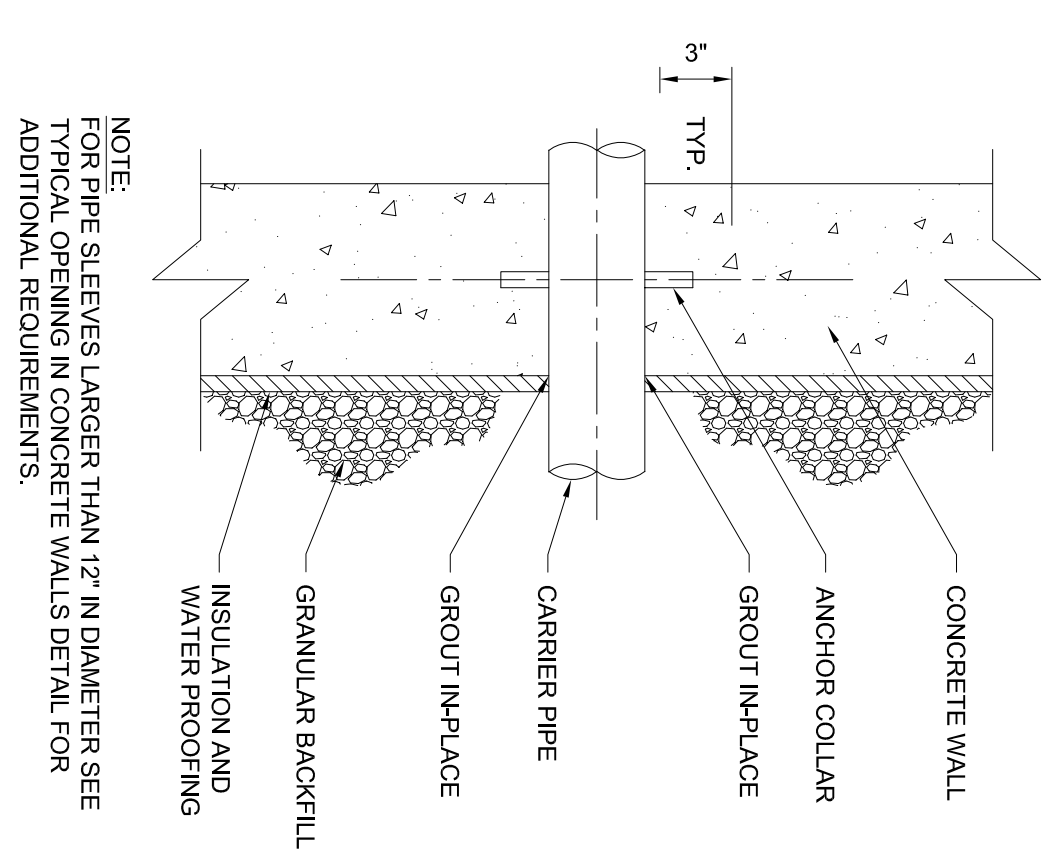

TYPICAL WALL PIPE DETAIL

3
S-3

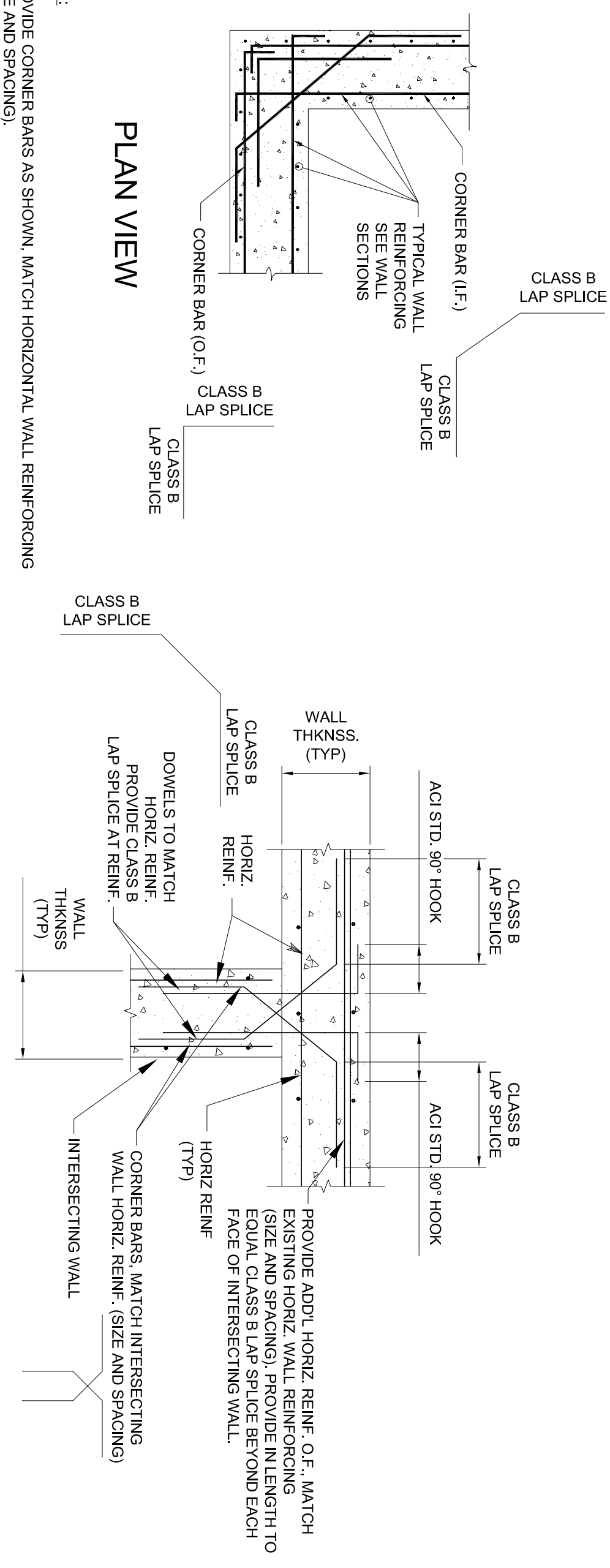

TYPICAL CORNER REINFORCEMENT FOR WALLS

4
S-3

TYPICAL REINFORCEMENT FOR INTERSECTION OF REINFORCED CONCRETE WALLS

5
S-3

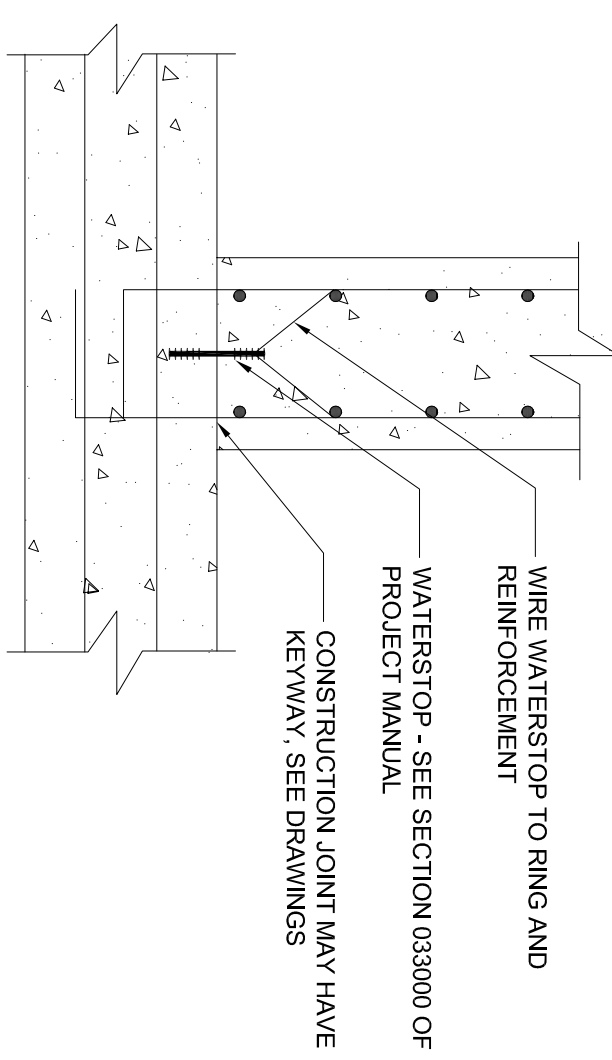

TYPICAL WATERSTOP DETAIL

7
S-3

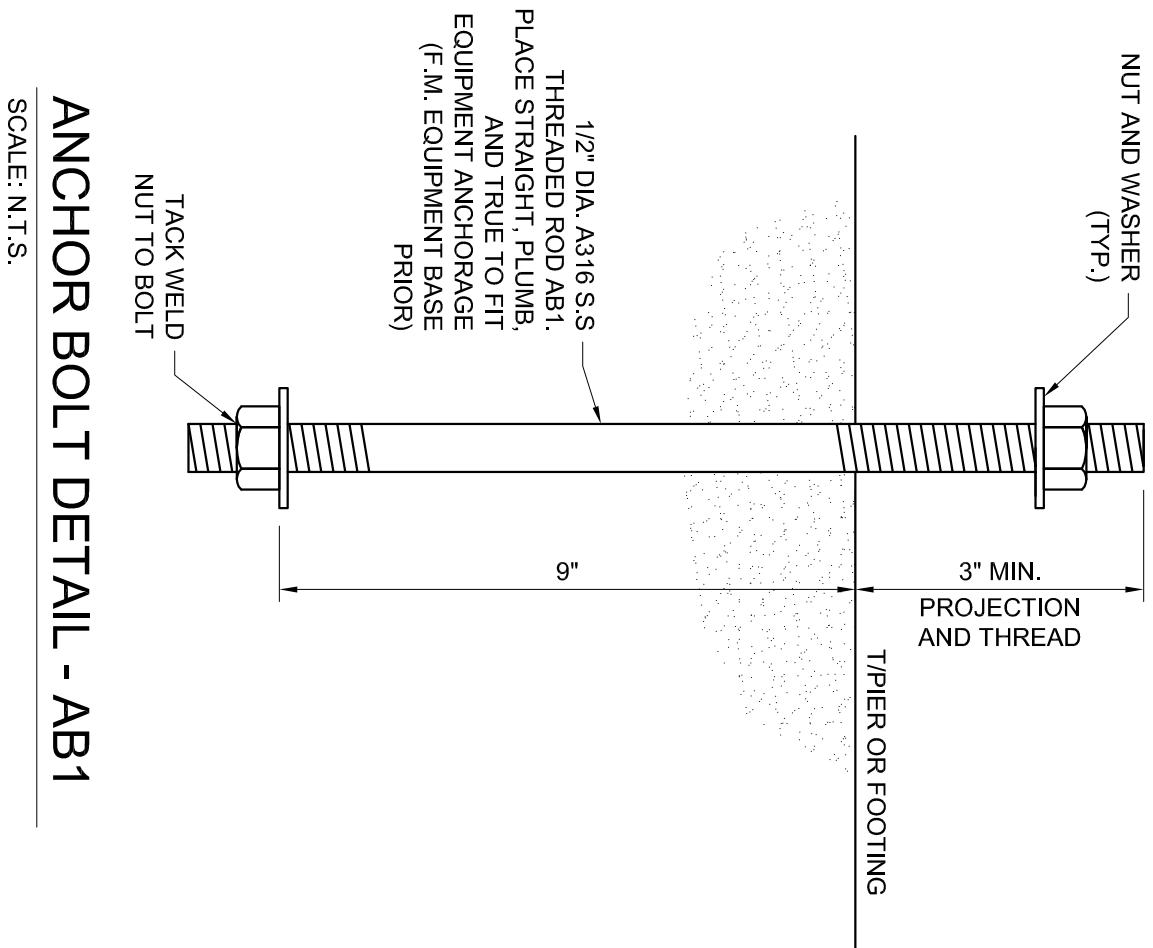

ANCHOR BOLT DETAIL - AB2

SCALE: N.T.S.

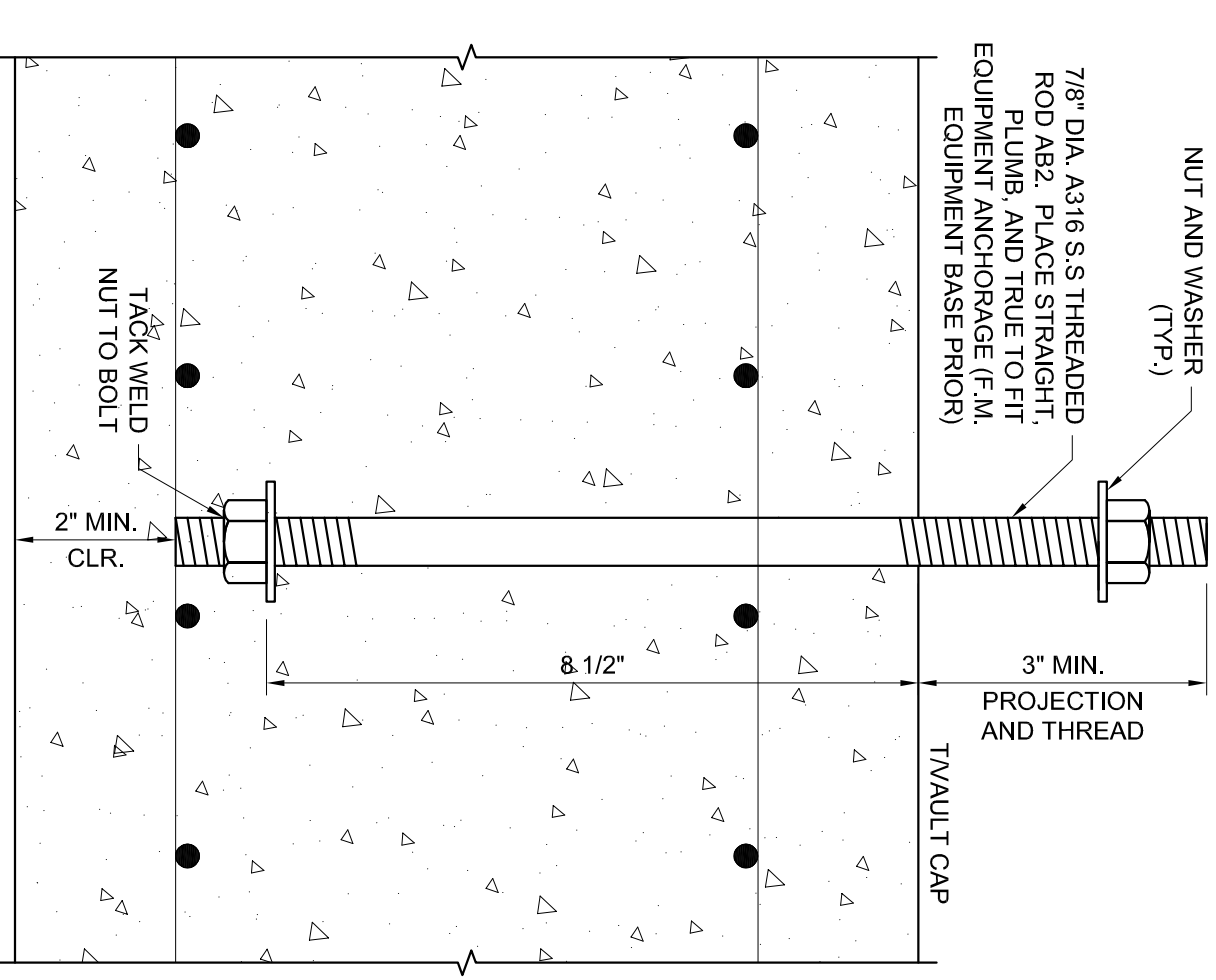

REVISIONS		
DATE	REVISION	BY

citizens water
A member of Citizens Energy Group

GMD
Geotechnical & Foundation Engineers
1402 N. Capitol Ave., Suite 200
Indianapolis, IN 46202
Phone: (317) 914-4244
Fax: (317) 914-4248

DEBRA K. STEINER
REGISTERED PROFESSIONAL ENGINEER
No. 10200708
STATE OF INDIANA
5/31/19

RECOMMENDED FOR APPROVAL	DAVE STEINER	5/31/19
DESIGNED:	DKS	DATE
CHECKED:	DKS	
DRAWN:	JAS	
CHECKED:	DKS	

**WHITE RIVER WELL #3
VOC REMOVAL
STRUCTURAL TYPICAL DETAILS**

CEG PROJECT NUMBER	2018002557
CONSULTANT PROJECT NUMBER	201800344
SHEET	S-3

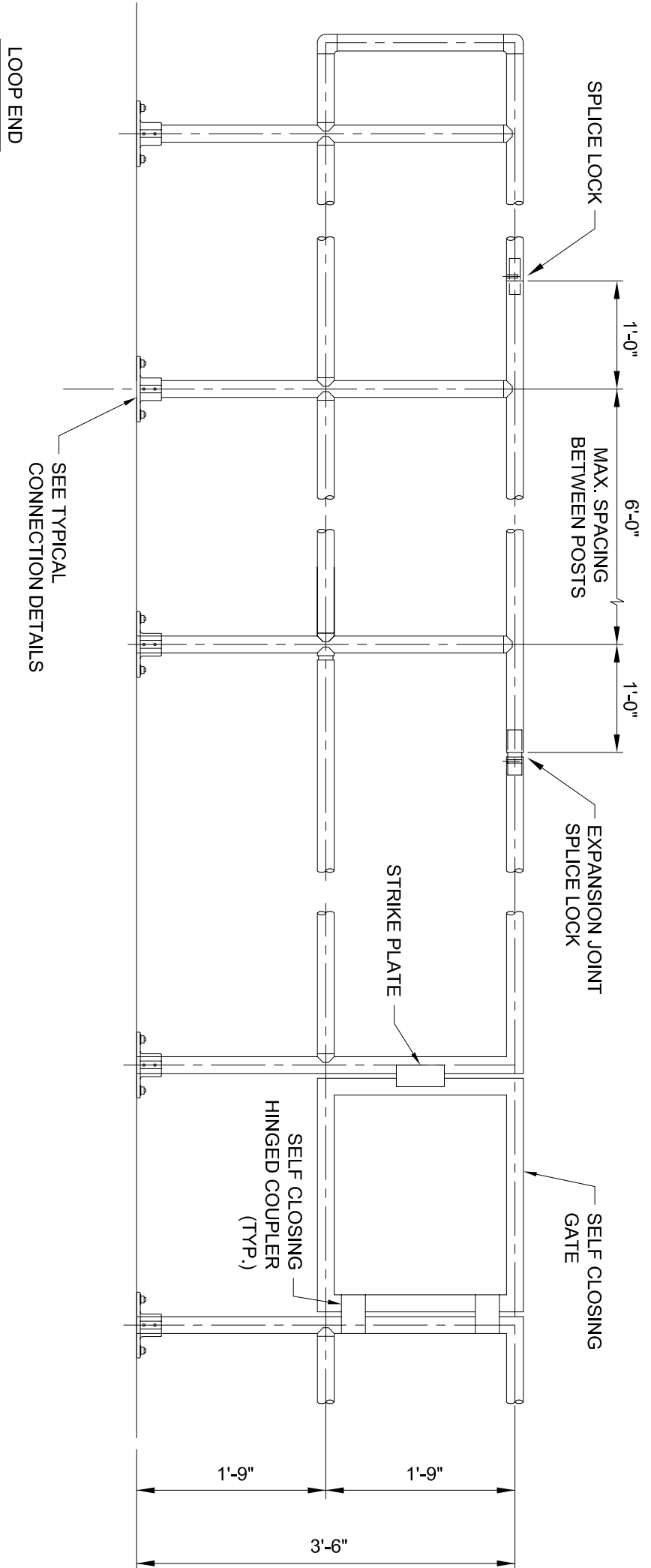

TYPICAL GUARD RAIL
GUARDRAILS SHALL BE TOP-MOUNTED, AS SHOWN ON PLANS
NOT TO SCALE

GUARD RAIL NOTES

- GUARDRAILS AND HANDRAILS SHALL BE THE PRODUCT OF A COMPANY NORMALLY ENGAGED IN THE MANUFACTURE OF PIPE RAILING. RAILING SHALL BE SHOP ASSEMBLED IN LENGTHS NOT TO EXCEED 24 FEET FOR FIELD ERECTION.
- THE HANDRAIL SHALL BE MADE OF PIPES JOINED TOGETHER WITH COMPONENT FITTINGS. SAMPLES OF ALL COMPONENTS, BASES, TOE PLATE AND PIPE SHALL BE SUBMITTED FOR APPROVAL AT THE REQUEST OF THE ENGINEER. COMPONENTS THAT ARE POP-RIVETED OR GLUED AT THE JOINTS WILL NOT BE ACCEPTABLE. ALL COMPONENTS MUST BE MECHANICALLY FASTENED WITH STAINLESS STEEL HARDWARE.
- RAILINGS SHALL BE 1 1/2" SCHEDULE 40 ALUMINUM PIPE ALLOY 6105-T5, 6063-T6, 6061-T6, ASTM-B-429 OR ASTM-B-221. POSTS SHALL BE 1 1/2" SCHEDULE 80 ALUMINUM PIPE OF THE SAME ALLOY. POST SPACING SHALL BE A MAXIMUM OF 6'-0".
- GUARDRAILS AND HANDRAILS SHALL BE DESIGNED TO WITHSTAND A 200 LB CONCENTRATED LOAD APPLIED IN ANY DIRECTION AND AT ANY POINT ON THE TOP RAIL. GUARDRAILS AND HANDRAILS SHALL ALSO BE DESIGNED TO WITHSTAND A UNIFORM LOAD OF 20 LB/FT APPLIED HORIZONTALLY TO THE TOP RAIL. UNIFORM LOADS ARE NOT TO BE APPLIED SIMULTANEOUSLY WITH THE CONCENTRATED LOADS.
- INTERMEDIATE RAILINGS SHALL BE PROVIDED SUCH THAT A 21-INCH SPHERE CANNOT PASS THROUGH ANY OPENING.
- INTERMEDIATE RAILINGS SHALL BE DESIGNED TO WITHSTAND A HORIZONTALLY APPLIED NORMAL LOAD OF 500 LBS ON AN AREA NOT TO EXCEED ONE SQUARE FOOT INCLUDING OPENINGS AND SPACES BETWEEN RAILS.
- THE MANUFACTURER SHALL SUBMIT CALCULATIONS FOR APPROVAL AT THE REQUEST OF THE ENGINEER. TESTING OF BASE CASTINGS OR BASE EXTRUSIONS BY AN INDEPENDENT LAB OR MANUFACTURER'S LAB (IF MANUFACTURER'S LAB CALCULATIONS, CALCULATIONS WILL BE REQUIRED FOR APPROVAL OF ALL OTHER DESIGN ASPECTS).
- POSTS SHALL NOT INTERRUPT THE CONTINUATION OF THE TOP RAIL AT ANY POINT ALONG THE RAILING, INCLUDING CORNERS AND END TERMINATIONS. THE TOP SURFACE OF THE TOP RAILING SHALL BE SMOOTH AND SHALL NOT BE INTERRUPTED BY PROJECTED FITTINGS.
- THE MID-RAIL AT A CORNER RETURN SHALL BE ABLE TO WITHSTAND A 200 LB LOAD WITHOUT LOOSENING. THE MANUFACTURER IS TO DETERMINE THIS DIMENSION FOR THEIR SYSTEM AND PROVIDE PHYSICAL LABORATORY TESTS TO CONFIRM COMPLIANCE.
- CONCRETE ANCHORS SHALL BE STAINLESS STEEL TYPE 303 OR 304 AND SHALL BE FURNISHED BY THE HANDRAIL MANUFACTURER. THE ANCHOR DESIGN SHALL INCLUDE THE APPROPRIATE REDUCTION FACTORS FOR SPACING AND EDGE DISTANCES IN ACCORDANCE WITH THE MANUFACTURER'S PUBLISHED DATA. CATHODIC BARRIER SHALL BE PLACED BETWEEN DISSIMILAR MATERIALS.
- TOE PLATE SHALL CONFORM TO OSHA STANDARDS. TOE PLATE SHALL BE A MINIMUM OF 4" HIGH AND SHALL BE AN EXTRUSION THAT ATTACHES TO THE POSTS WITH CLAMPS THAT WILL ALLOW FOR EXPANSION AND CONTRACTION BETWEEN POSTS. TOE PLATES SHALL BE SET 1/4" ABOVE THE WALKING SURFACE. TOE PLATES SHALL BE PROVIDED ON HANDRAILS AS REQUIRED BY OSHA AND/OR AS SHOWN ON DRAWINGS. TOE PLATES SHALL BE SHIPPED LOOSE IN STOCK LENGTHS FOR FIELD INSTALLATION.
- OPENINGS IN THE RAILING SHALL BE GUARDED BY A SELF-CLOSING GATE. SAFETY CHAINS SHALL NOT BE USED UNLESS SPECIFICALLY SHOWN ON THE DRAWINGS.
- FINISH SHALL BE SMOOTH EXTRUSION.
- ALUMINUM SURFACES IN CONTACT WITH STEEL, CONCRETE, GROUT OR DISSIMILAR METALS WILL BE PROTECTED WITH A COAT OF BITUMINOUS PAINT, MYLAR ISOLATORS OR OTHER APPROVED MATERIAL.
- REFER TO SPECIFICATION SECTION 05520 FOR ADDITIONAL REQUIREMENTS.
- CONCRETE ANCHOR DIAMETER, EDGE DISTANCES, EMBEDMENT, AS WELL AS POST SPACING, TO BE DETERMINED UPON ANCHOR SELECTION.

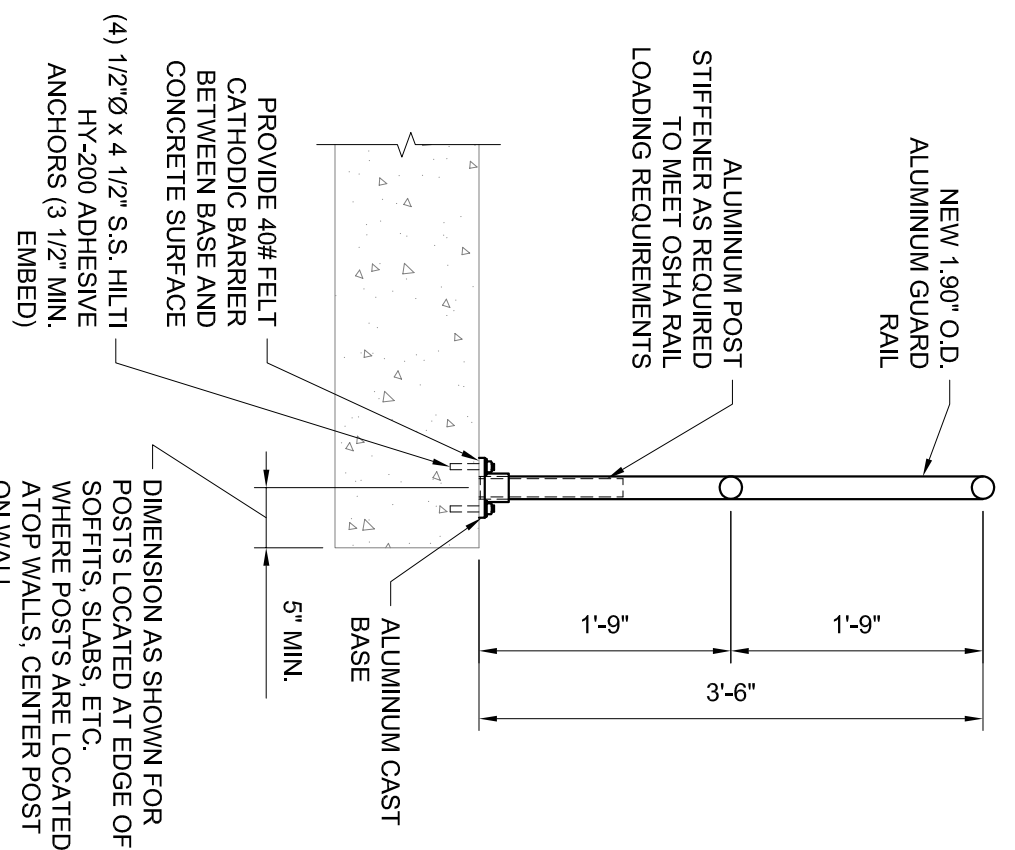

TYPICAL GUARD RAIL SECTION
NOT TO SCALE

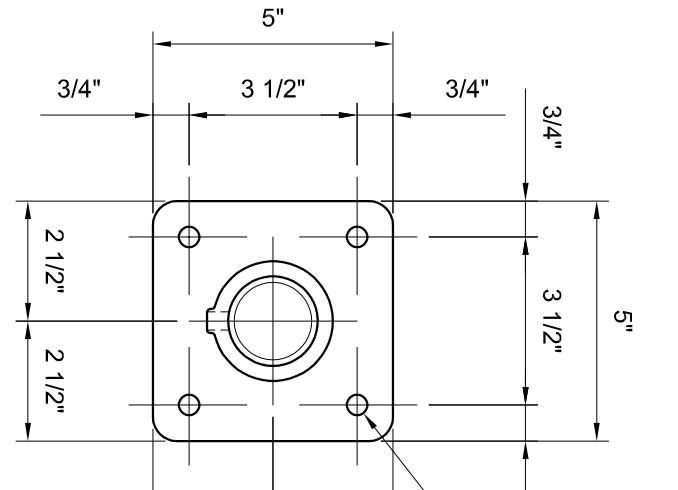

TYPICAL AL. CAST BASE
NOT TO SCALE

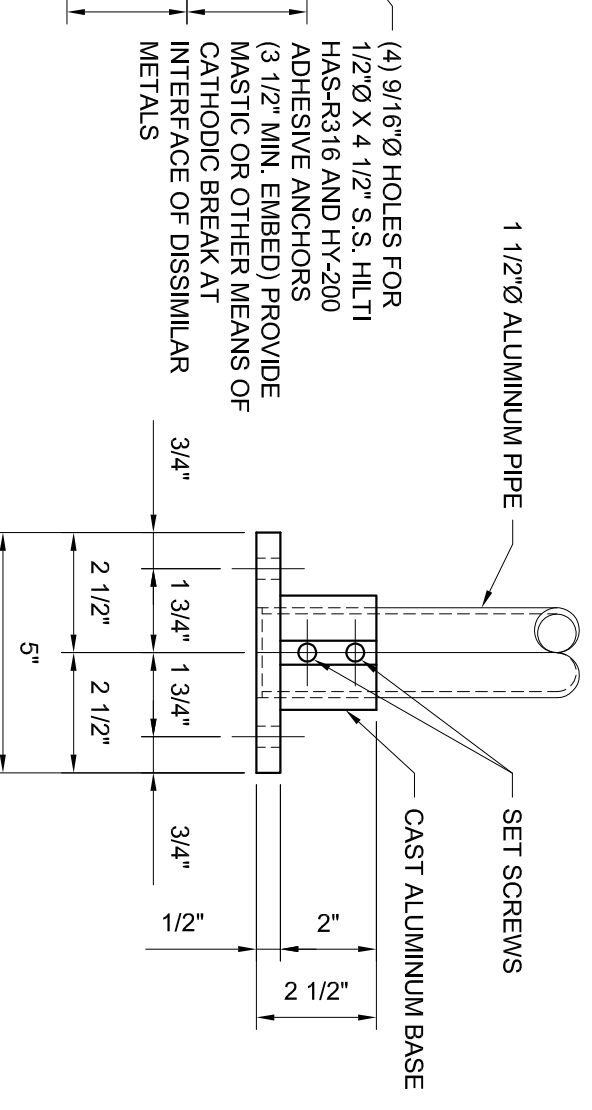

TYPICAL TOP MOUNT CONNECTION TO STRINGER
NOT TO SCALE

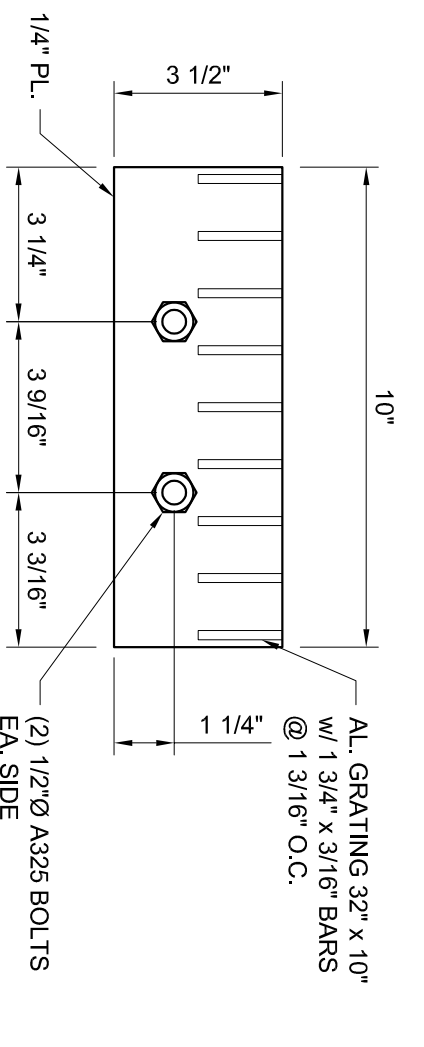

SECTION B
SCALE: 3\"/>

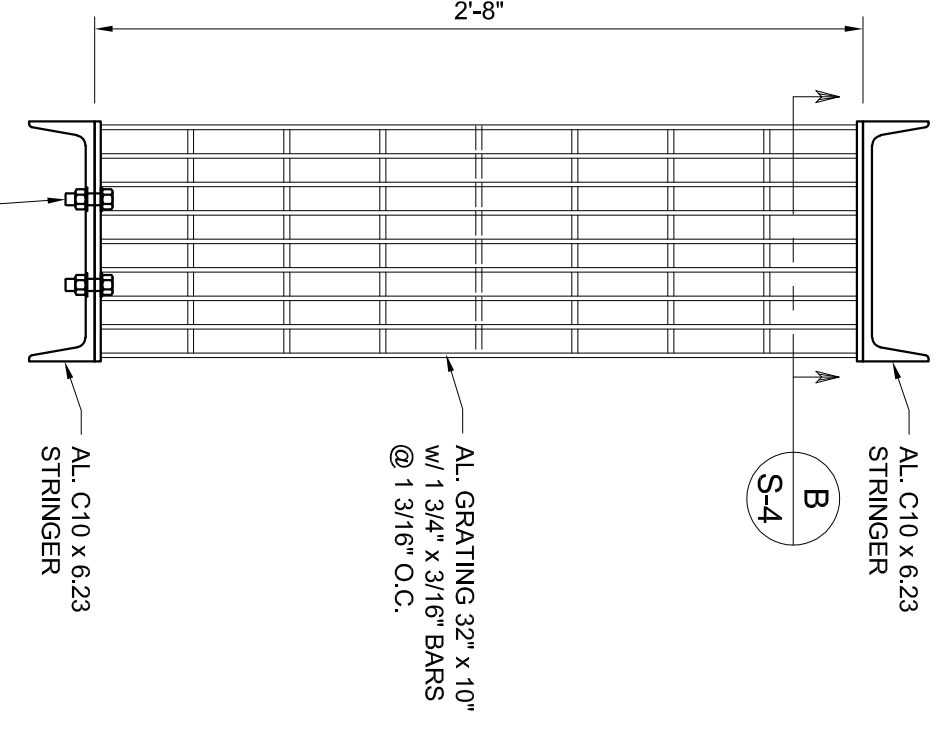

DETAIL A
SCALE: 1 1/2\"/>

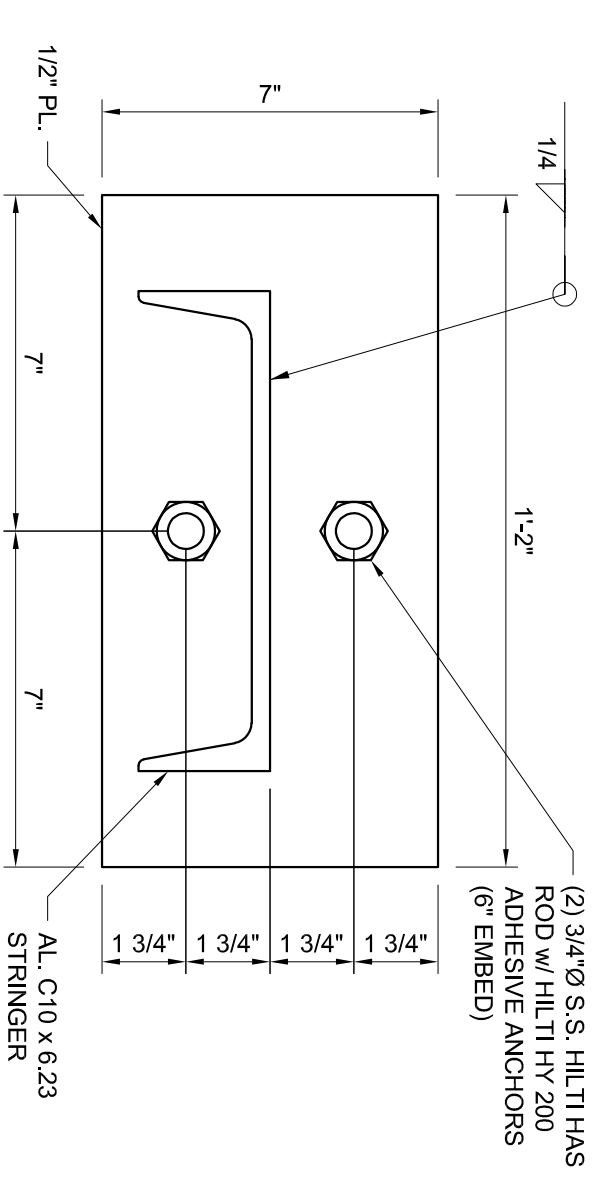

SECTION C
SCALE: 3\"/>

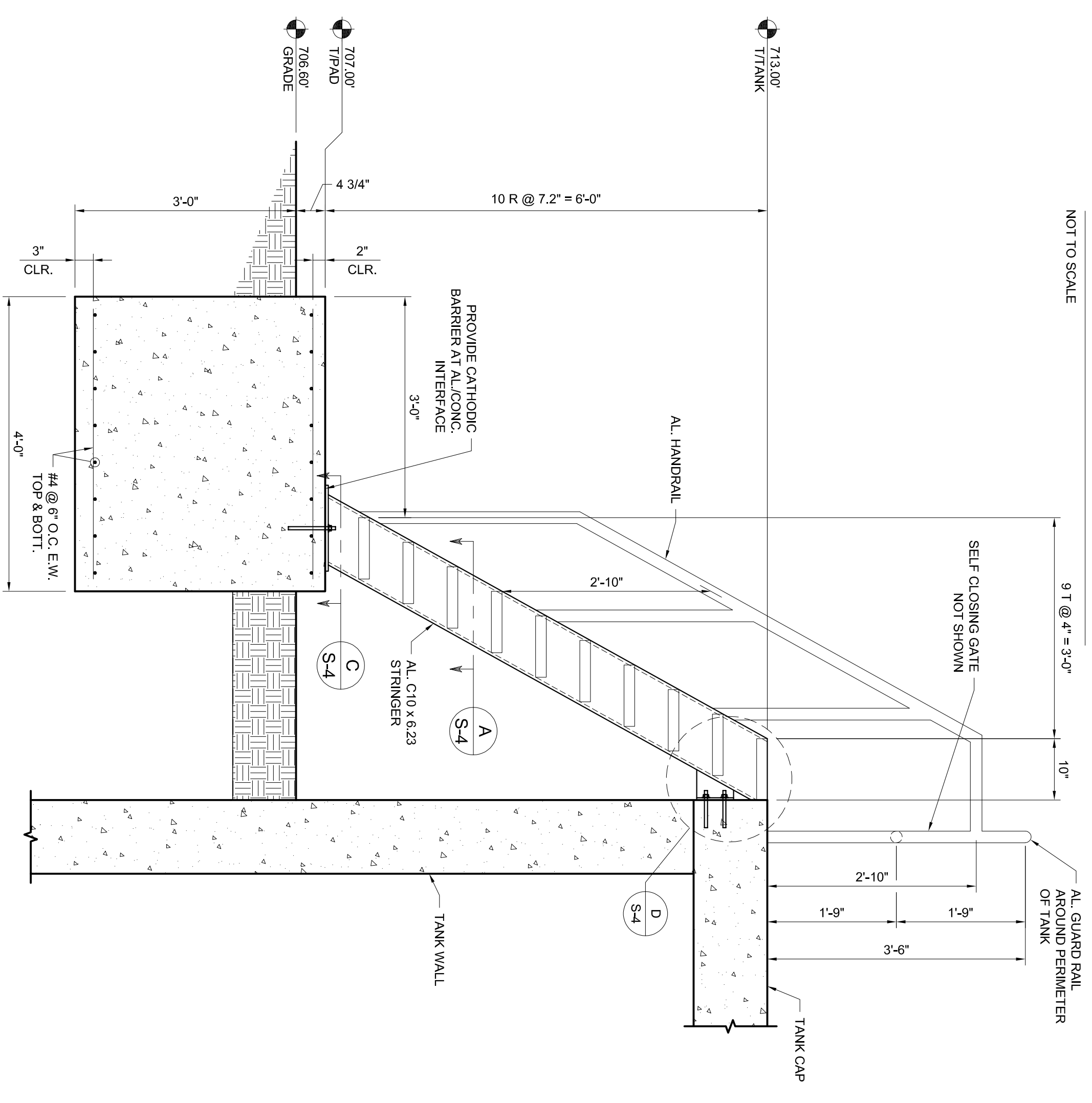

LADDER SECTION
SCALE: 3/4\"/>

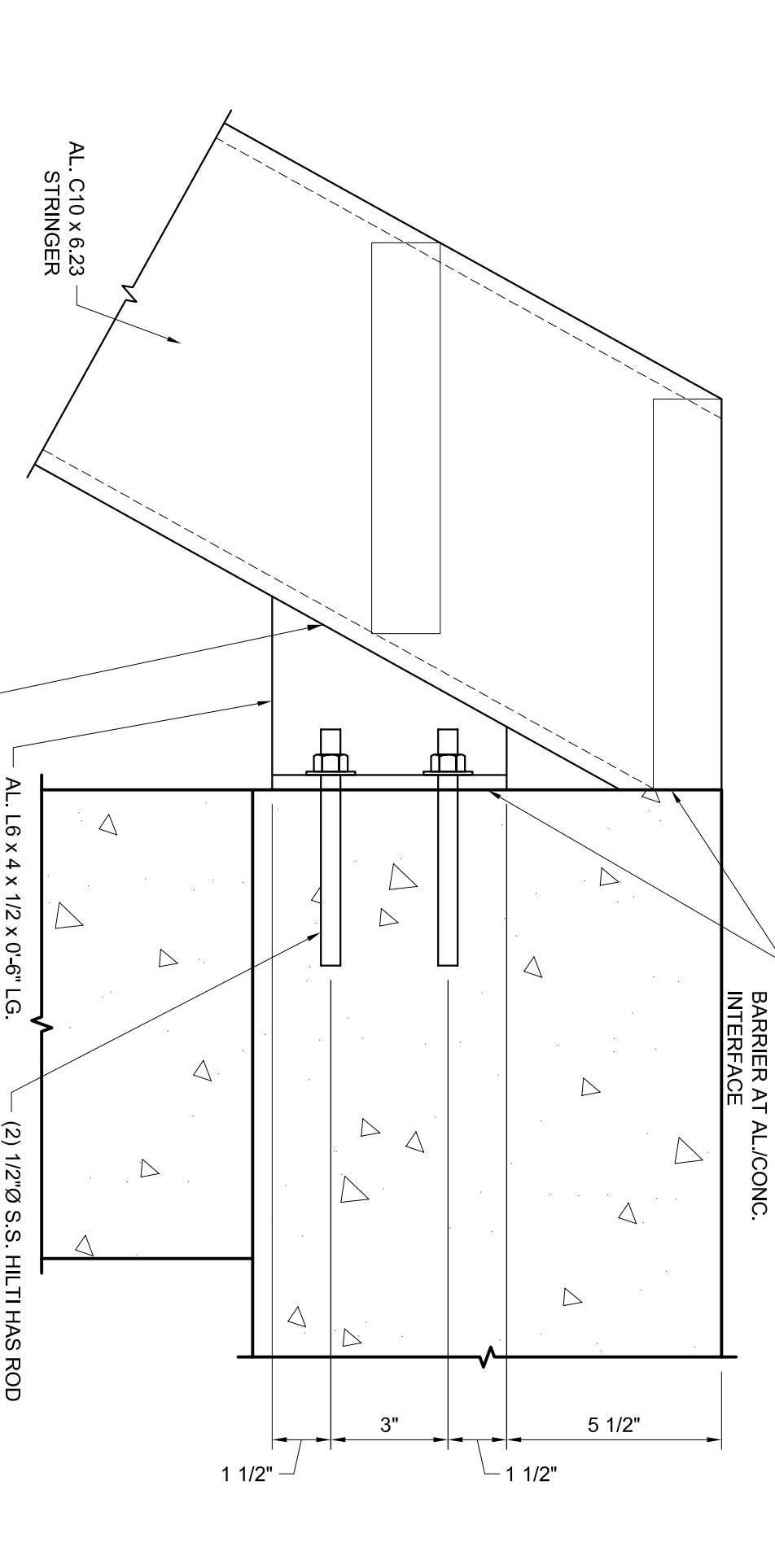

DETAIL D
SCALE: 3\"/>

REVISIONS		
DATE	REVISION	BY

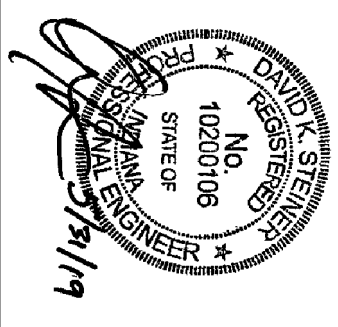

RECOMMENDED FOR APPROVAL	DAVE STEINER	5/31/19
DESIGNED:	DKS	DATE
CHECKED:	DKS	CHECKED:
DRAWN:	JAS	
CHECKED:	DKS	

WHITE RIVER WELL #3
VOC REMOVAL
STRUCTURAL TYPICAL DETAILS

CEG PROJECT NUMBER	20WR02557
CONSULTANT PROJECT NUMBER	201800344
SHEET	S-4

REVISIONS		BY
DATE	REVISION	



GMID
 GEOTECHNICAL INVESTIGATIONS & LABOR SERVICES
 1402 N. Central Ave.
 Suite 200
 Indianapolis, IN 46202
 Phone (317) 517-4244
 Fax (317) 517-4250
 www.gmidinc.com

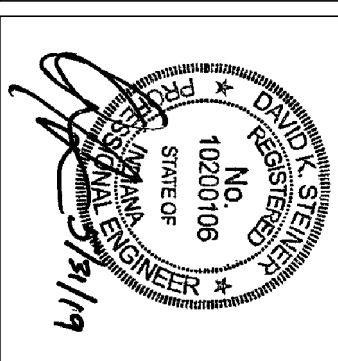

RECOMMENDED FOR APPROVAL	DAVE STEINER	5/31/19
DESIGNED:	DKS	DATE
CHECKED:	DKS	
DRAWN:	JAS	
CHECKED:	DKS	

**WHITE RIVER WELL #3
 VOC REMOVAL
 EQUIPMENT PAD DETAILS**

CEG PROJECT NUMBER	20WR02557
CONSULTANT PROJECT NUMBER	201800344
SHEET	S-5

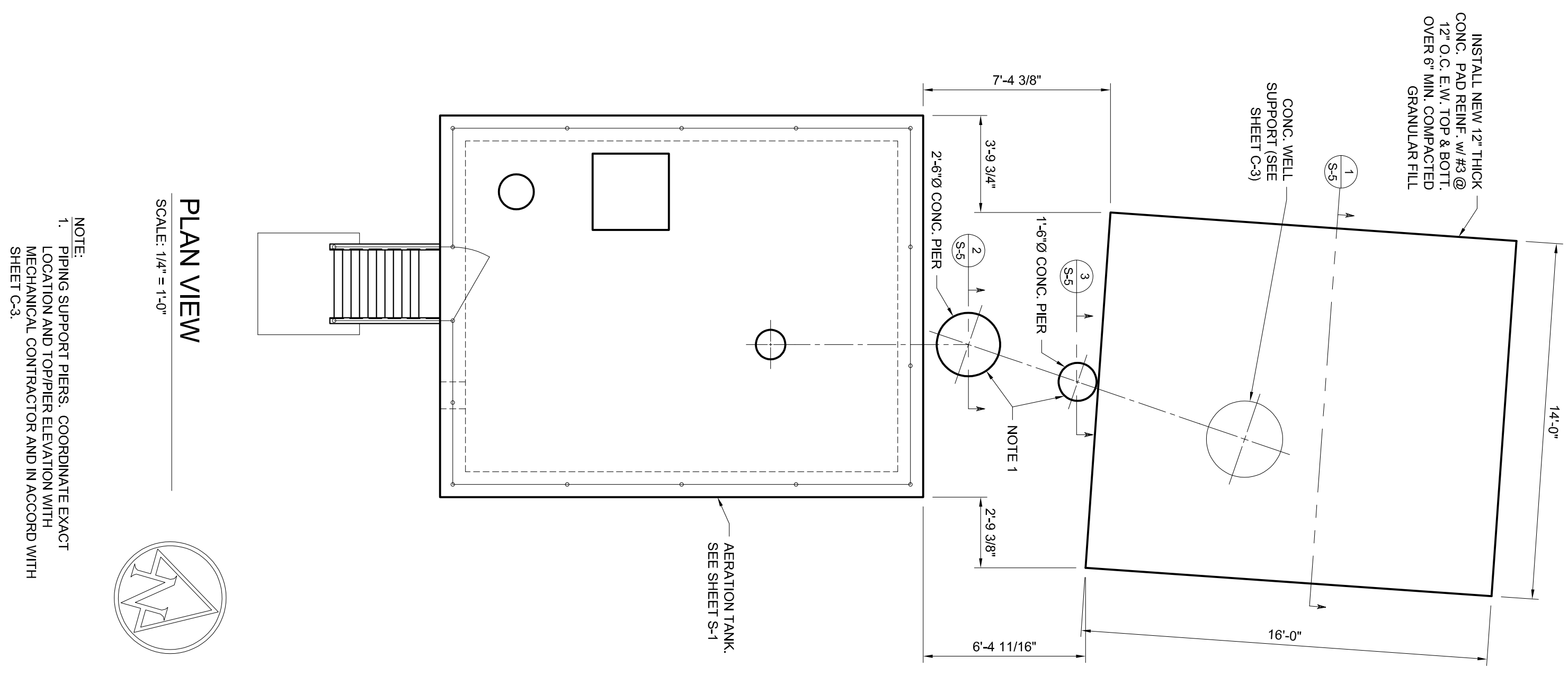

PLAN VIEW
 SCALE: 1/4" = 1'-0"

NOTE:
 1. PIPING SUPPORT PIERS. COORDINATE EXACT LOCATION AND TOP/PIER ELEVATION WITH MECHANICAL CONTRACTOR AND IN ACCORD WITH SHEET C-3.

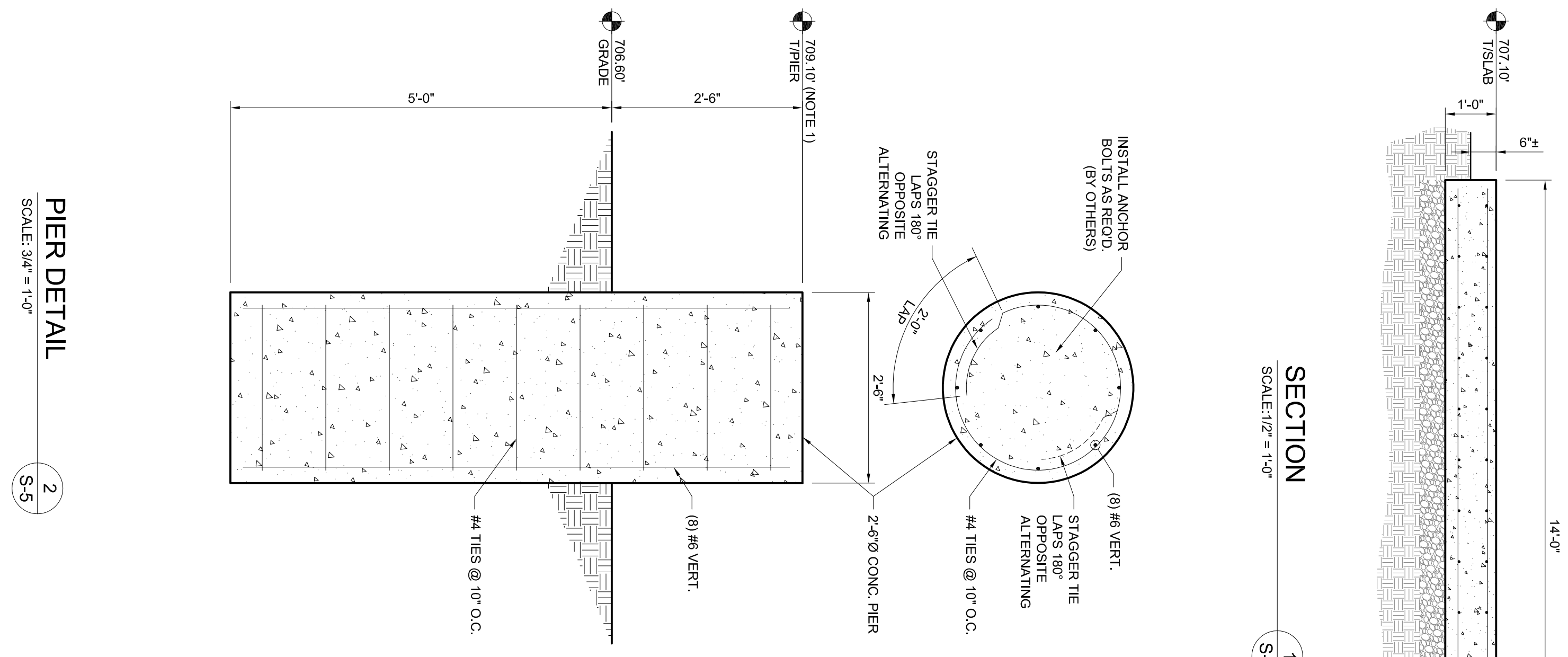
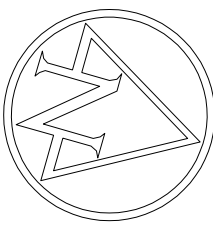

SECTION
 SCALE: 1/2" = 1'-0"

2
 SCALE: 3/4" = 1'-0"

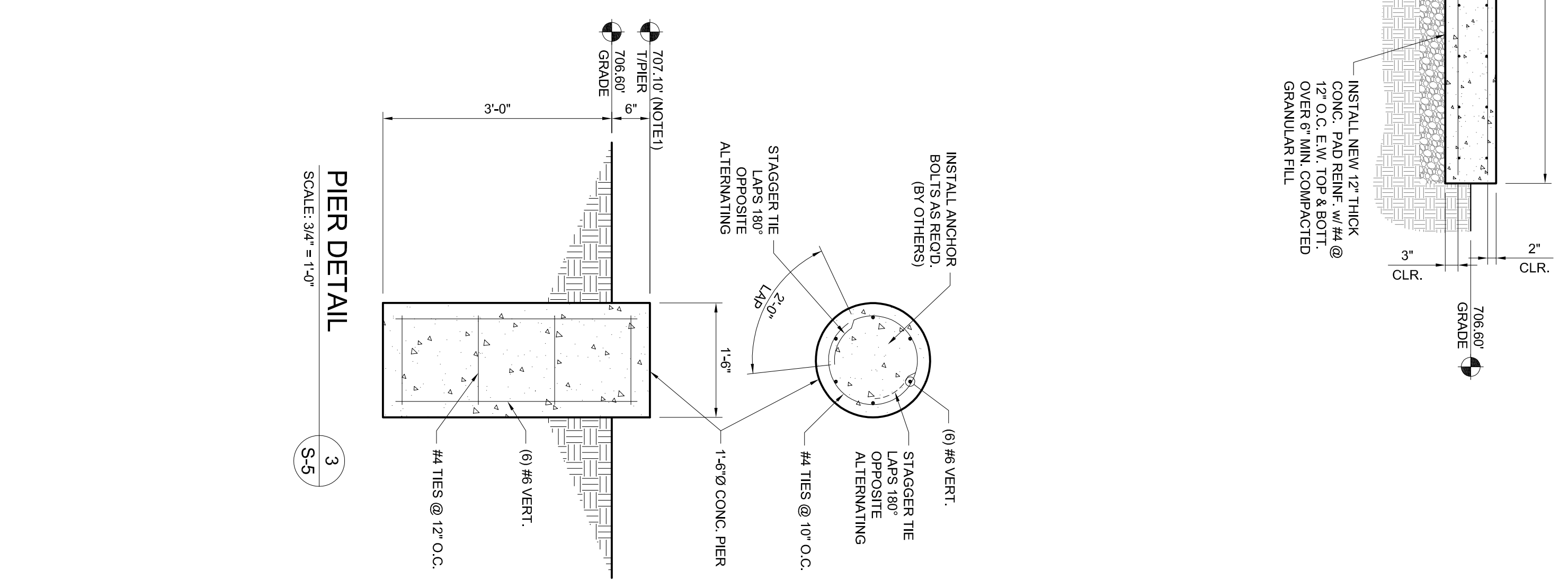
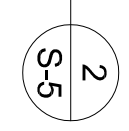

PIER DETAIL
 SCALE: 3/4" = 1'-0"

3
 SCALE: 3/4" = 1'-0"



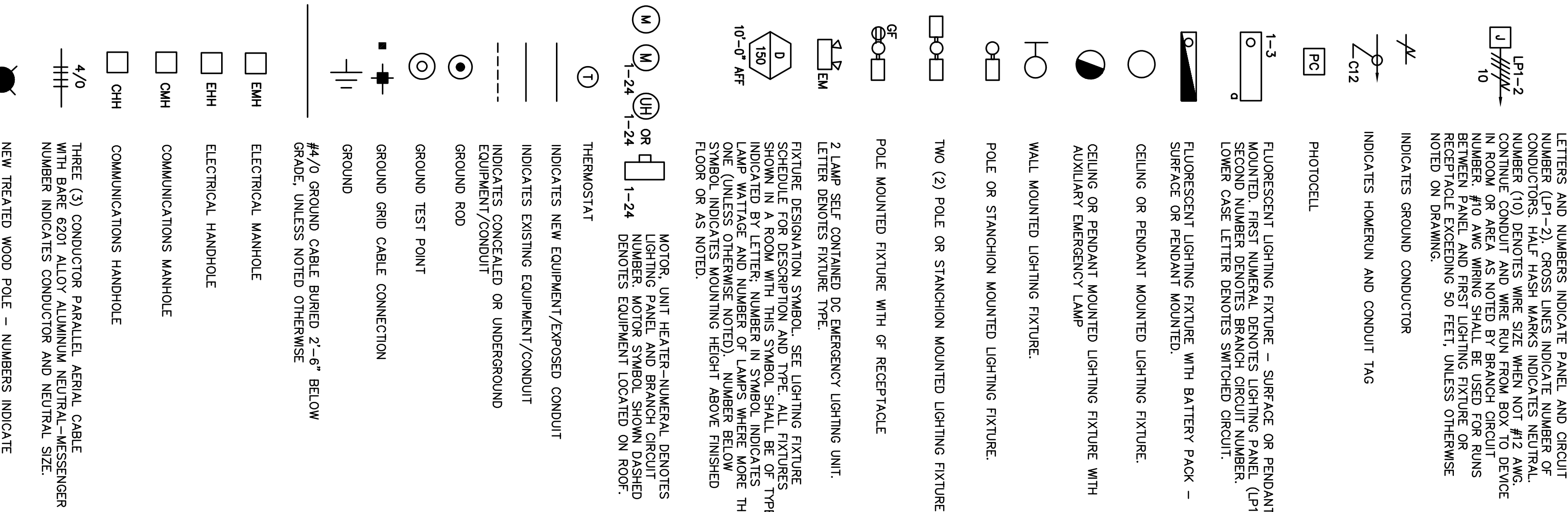
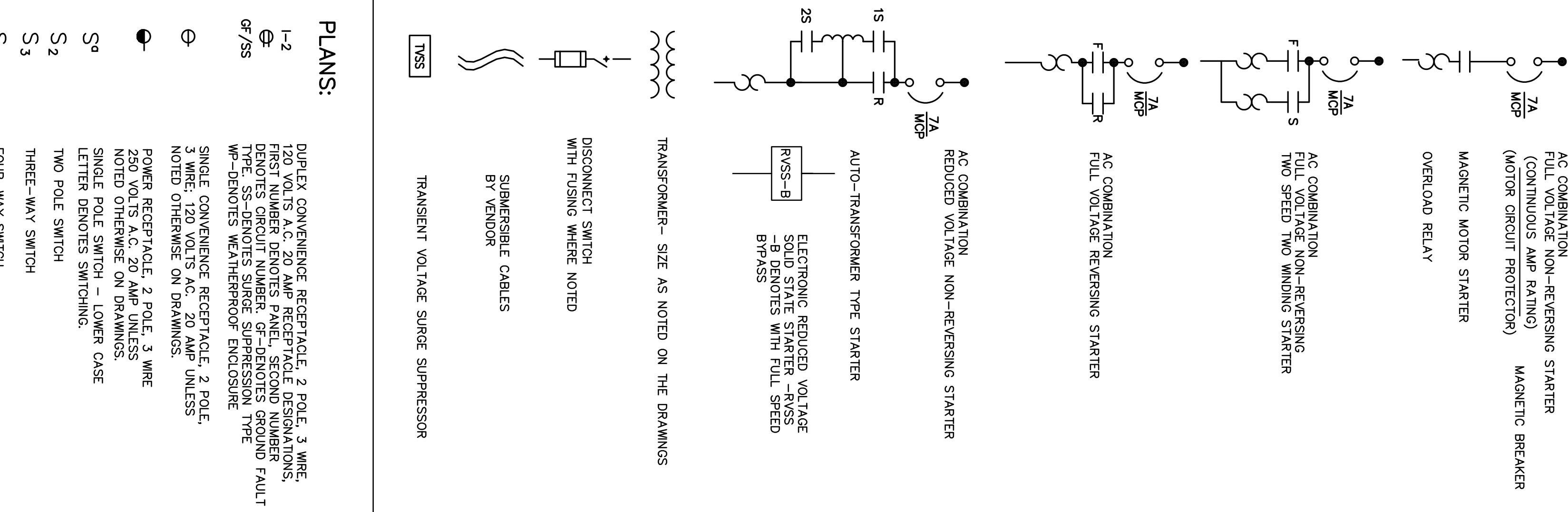
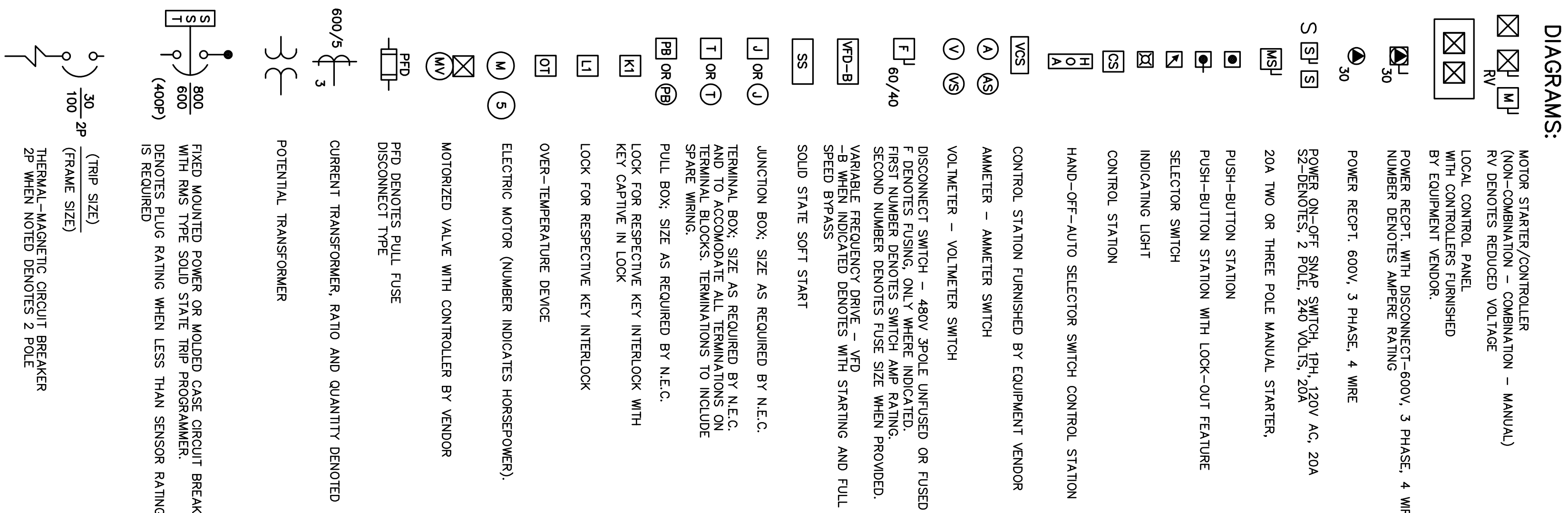

ABBREVIATIONS:

AFF	ABOVE FINISHED FLOOR
AFG	ABOVE FINISHED GRADE
ATS	AUTOMATIC TRANSFER SWITCH
AWG	AMERICAN WIRE GAUGE
BKR	BREAKER
CBV	CABLE BY VENDOR
CKT	CIRCUIT
CNTRL	CONTROL PANEL, NUMBER AS NOTED
CP-1	CONTROL POWER TRANSFORMER
CT	CURRENT TRANSFORMER
DN	DOWN
DPDT	DOUBLE POLE DOUBLE THROW
EC	EMPTY CONDUIT
EL ELEV	ELEVATION
EP	EXPLOSION PROOF
EXIST	EXISTING
FDR	FEEDER
FXT	FIXTURE
FVNR	FULL VOLTAGE NON-REVERSING
G	GALVANIZED
GEC	GROUNDING ELECTRODE CONDUCTOR
GND	GROUND
GRS	GALVANIZED RIGID STEEL (CONDUIT)
HQA	HAND/OFF/AUTO
JB OR J	JUNCTION BOX, CONDULET, FITTING AS REQUIRED BY N.E.C., UNLESS NOTED OTHERWISE
KOHL OR MO	THOUSAND CIRCULAR MILS
LA	LIGHTNING ARRESTOR
LCP	LOCAL CONTROL PANEL
LITG	LIGHTING
MCC	MOTOR CONTROL CENTER
MTS	MANUAL TRANSFER SWITCH
NA	NON-AUTOMATIC
NGTC	NORMALLY CLOSED, TIME CLOSE
NOTO	NORMALLY OPEN, TIME OPEN
NOTO	NORMALLY OPEN, TIME OPEN
NTO	NORMALLY OPEN, TIME OPEN
NTO	NORMALLY OPEN, TIME OPEN
NTO	NORMALLY OPEN, TIME OPEN
P/B, PB	PULL BOX
PFD	PULL FUSE DISCONNECT
PNL	PANEL
PFC	POWER FACTOR CORRECTION CAPACITORS
PT	POTENTIAL TRANSFORMER
RECEP	RECEPTACLE
RMC	RIGID METAL CONDUIT
RVNR	REDUCED VOLTAGE NON-REVERSING
(S) (SH)	SHIELDED CABLE
SP	SPARE
SEL	SELECTOR
SWBD	SWITCHBOARD
SWGR	SWITCHGEAR
TEW	THERMOCOUPLE EXTENSION WIRE
UON	UNLESS OTHERWISE NOTED
USE	UNDERGROUND SERVICE ENTRANCE
WP	WEATHERPROOF
WT	WINDING TEMPERATURE RELAY
XFMR	TRANSFORMER
NEC	NATIONAL ELECTRIC CODE
TYP	TYPICAL

- ### GENERAL ELECTRICAL DEMOLITION NOTES:
- EXISTING SITE CONDITIONS HAVE BEEN RESEARCHED BY THE ENGINEER. IF EXISTING SITE CONDITIONS DIFFER FROM THESE PLAN SHEETS, CONTRACTOR SHALL NOTIFY OWNER'S REPRESENTATIVE AND ENGINEER.
 - OWNER HAS THE FIRST RIGHT OF REFUSAL FOR ALL ELECTRICAL AND EQUIPMENT BEING REMOVED. ELECTRICAL EQUIPMENT, CONDUIT AND CONDUITORS NOT CLAIMED BY OWNER SHALL BE REMOVED FROM SITE AND DISPOSED OF AS DETERMINED BY THE CONTRACTOR.
 - REMOVE ALL HANGERS, RODS, WOOD SPACERS, BRACKETS, SCREWS AND NAILS ASSOCIATED CONDUITS AND PANELS BEING REMOVED.
 - COORDINATE WORK WITH OWNERS SCHEDULED USE OF SITE.
- ### GENERAL ELECTRICAL INSTALLATION NOTES:
- EXISTING SITE CONDITIONS HAVE BEEN RESEARCHED BY THE ENGINEER. IF EXISTING SITE CONDITIONS DIFFER FROM THESE PLAN SHEETS, CONTRACTOR SHALL NOTIFY OWNER'S REPRESENTATIVE AND ENGINEER.
 - CONTRACTOR SHALL PERFORM ALL WORK AS REQUIRED BY FEDERAL, STATE, LOCAL LAWS AND ORDINANCES.
 - CONTRACTOR SHALL FURNISH AND INSTALL ALL EQUIPMENT AS SHOWN AND NOTED ON ALL PLAN SHEETS.
 - EXISTING EQUIPMENT IDENTIFIED TO REMAIN SHALL BE REMOVED, PROTECTED FROM DAMAGE AND REINSTALLED IN A WORKING MANNER.
 - COORDINATE WORK WITH OWNERS SCHEDULED USE OF SITE.

GENERAL NOTE FOR THIS SHEET:

- THE SYMBOLS AND ABBREVIATIONS LIST ON THIS SHEET IS A COMPREHENSIVE STANDARD GUIDE INTENDED FOR GENERAL USE ON ALL PROJECTS. THEREFORE NOT ALL THE SYMBOLS AND ABBREVIATIONS CONTAINED IN THIS LIST ARE NECESSARILY USED ON THIS PARTICULAR PROJECT AND SHOULD BE USED FOR CLARIFICATION ONLY.

DATE	REVISION	BY

Citizens Water
A member of Citizens Energy Group

GMID
GENERAL MIDDLEBURY INDUSTRIAL DESIGN
1402 N. Canal Ave.
Suite 200
Indianapolis, IN 46202
Phone (317) 974-4244
Fax (317) 974-4249
www.gmidinc.com

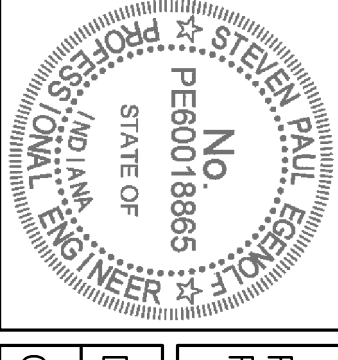

RECOMMENDED FOR APPROVAL	DESIGNED: SPE	DRAWN: JAS
DESIGNED: SPE	CHECKED: SPE	CHECKED: SPE
<i>Steven P. Eberhart</i>	DATE: 05/31/19	

WHITE RIVER WELL #3		CEG PROJECT NUMBER
VOC REMOVAL		20MR2557
SYMBOLS, LEGEND AND GENERAL NOTES		CONSULTANT PROJECT NUMBER
		201800344
		SHEET
		E-0

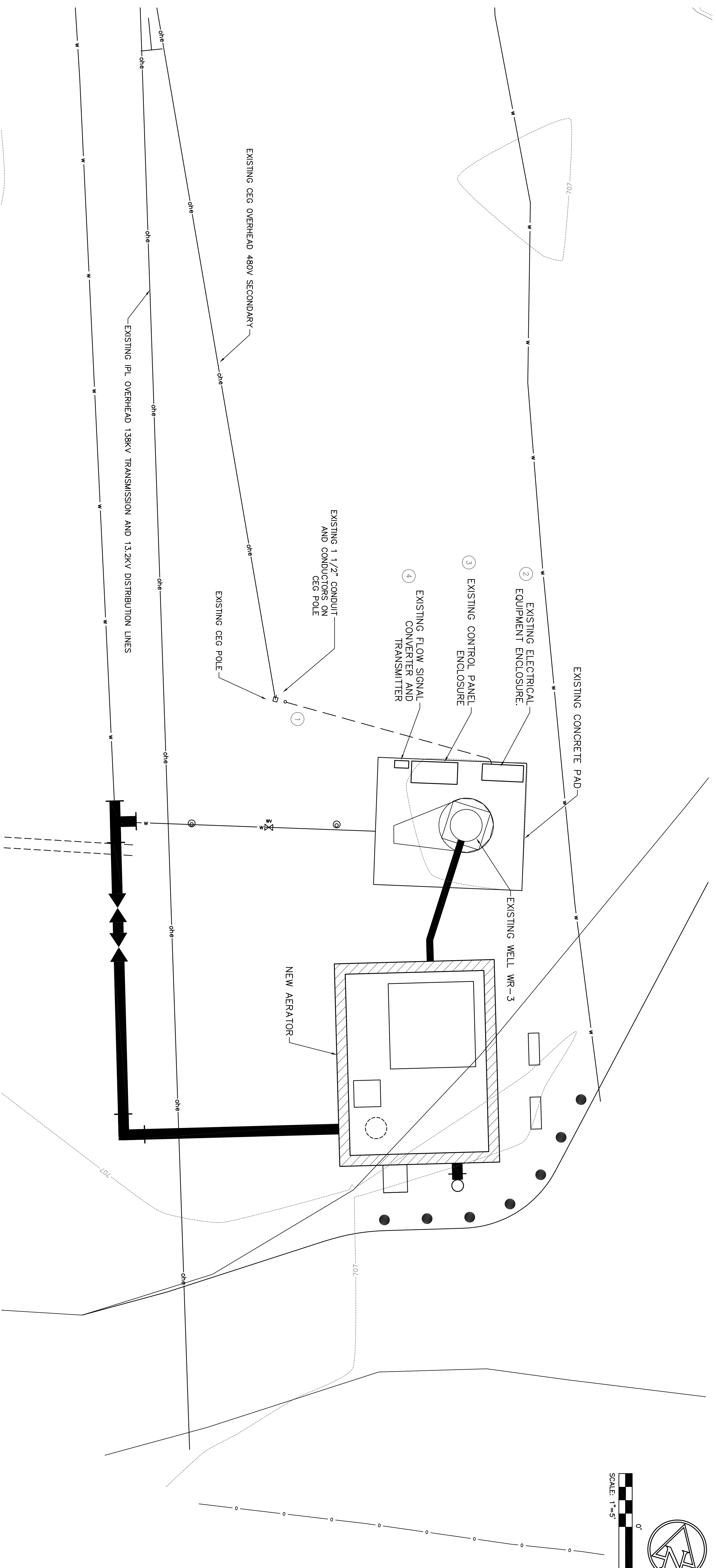

ELECTRICAL SITE PLAN KEYED NOTES: ○

- ① REMOVE EXISTING ELECTRICAL RISER ON CEG POLE AT THIS LOCATION. REMOVE CONDUIT AND CONDUCTORS BELOW SURFACE BETWEEN POLE AND ELECTRICAL EQUIPMENT ENCLOSURE.
- ② REMOVE ELECTRICAL EQUIPMENT ENCLOSURE AND SUPPORTING UNSTRUT BETWEEN ENCLOSURE AND EQUIPMENT.
- ③ REMOVE CONTROL PANEL ENCLOSURE, ANTENNA AND SUPPORTING UNSTRUT AT THIS LOCATION. PROTECT CONTROL PANEL ENCLOSURE AND ANTENNA FROM DAMAGE. PREPARE ENCLOSURE AND ASSOCIATED UNSTRUT FOR INSTALLATION ON NEW CONCRETE PAD. SEE SHEETS E-2 AND E-3 FOR ADDITIONAL DETAILS.
- ④ REMOVE FLOW METER EQUIPMENT AND SUPPORTING UNSTRUT AT THIS LOCATION. PROTECT FLOW METER EQUIPMENT FROM DAMAGE. PREPARE FLOW METER EQUIPMENT AND ASSOCIATED UNSTRUT FOR INSTALLATION ON NEW CONCRETE PAD. SEE SHEETS E-2 AND E-3 FOR ADDITIONAL DETAILS.

REVISIONS	
DATE	BY



GMID
 ENGINEERS ARCHITECTS & LAND SURVEYORS
 WWW.GMIDINC.COM

1402 N. Central Ave.
 Suite 200
 Indianapolis, IN 46202
 Phone (317) 917-4244
 Fax (317) 917-4250



RECOMMENDED FOR APPROVAL	DESIGN ENGINEER	DATE
<i>Steven P. Segenoff</i>		05/31/19
DESIGNED: SPE	DRAWN: JAS	
CHECKED: SPE	CHECKED: SPE	

WHITE RIVER WELL #3
VOC REMOVAL
 ELECTRICAL SITE PLAN

CEG PROJECT NUMBER	20WRQ2557
CONSULTANT PROJECT NUMBER	201800344
SHEET	E-1

DATE	REVISION	BY

- PLAN NOTES
1. PROVIDE ELECTRICAL COMPONENTS AS SHOWN ON THIS DRAWING.
 2. SEE DRAWING E-3 FOR DETAILS OF VFD ENCLOSURE.
 3. UNDERGROUND CONDUITS SHALL HAVE MINIMUM COVER AS NOTED.

ELECTRICAL PLAN
SCALE: 1/4"=1'-0"

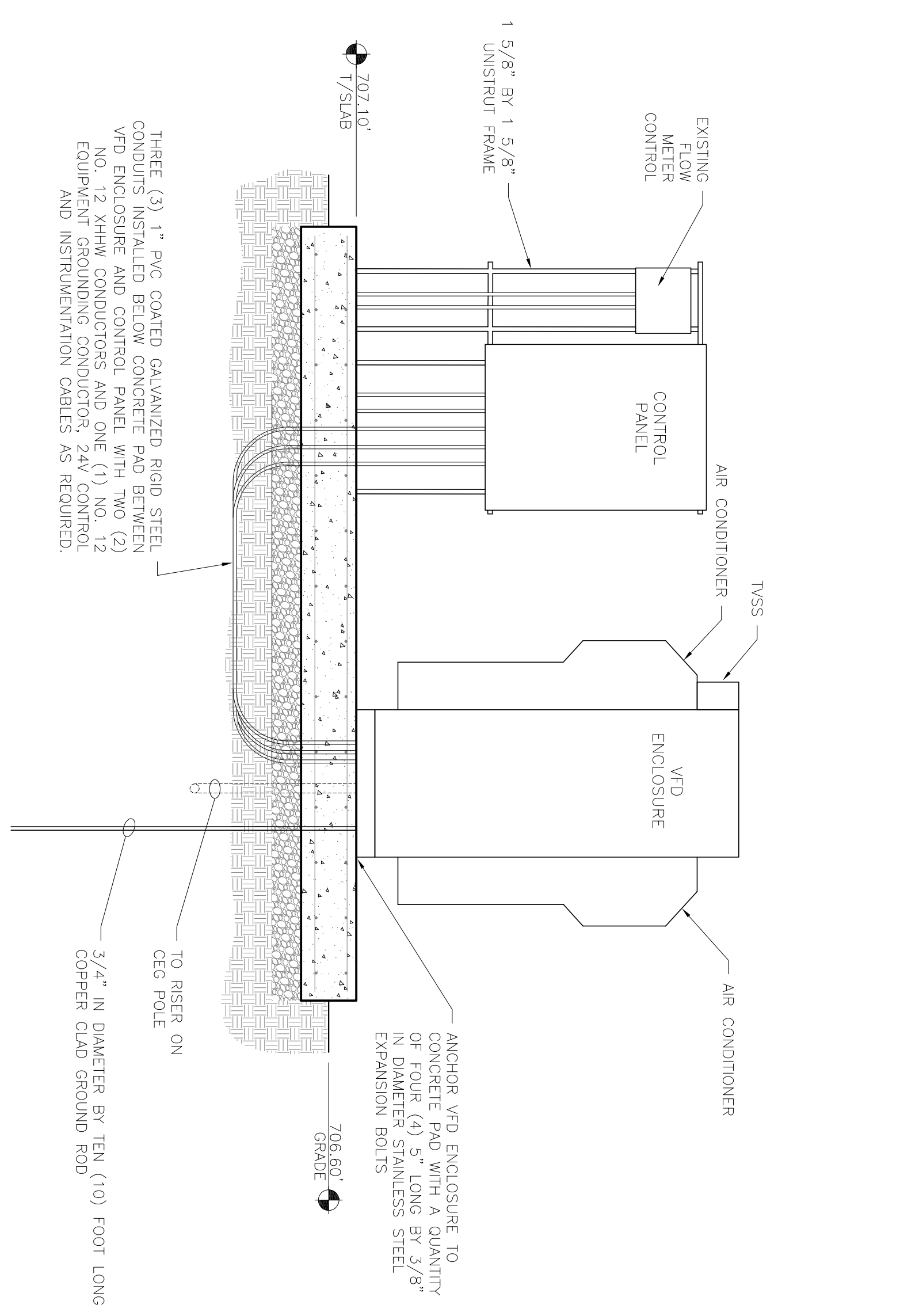
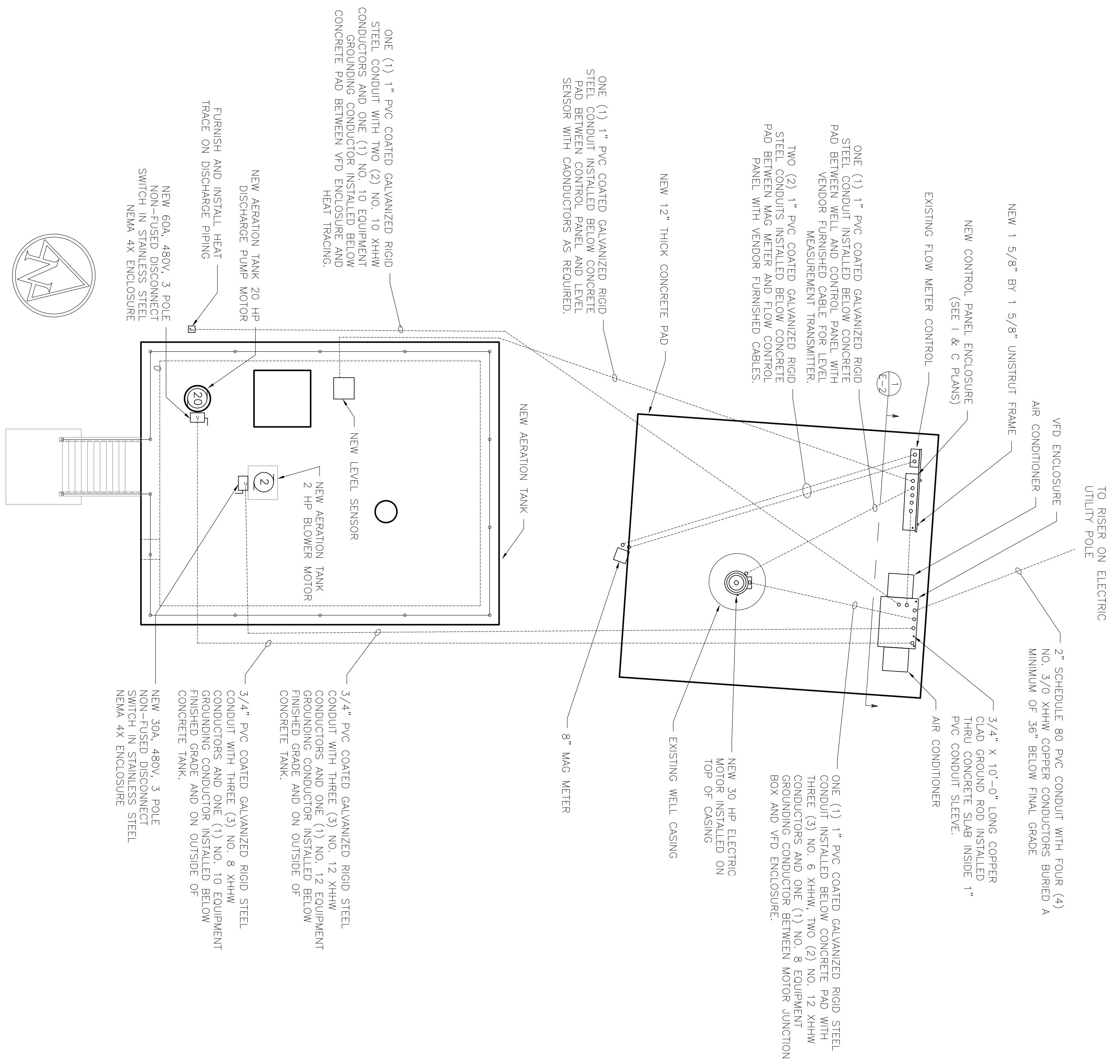

ELECTRICAL SECTION 1
SCALE: 1/2"=1'-0"

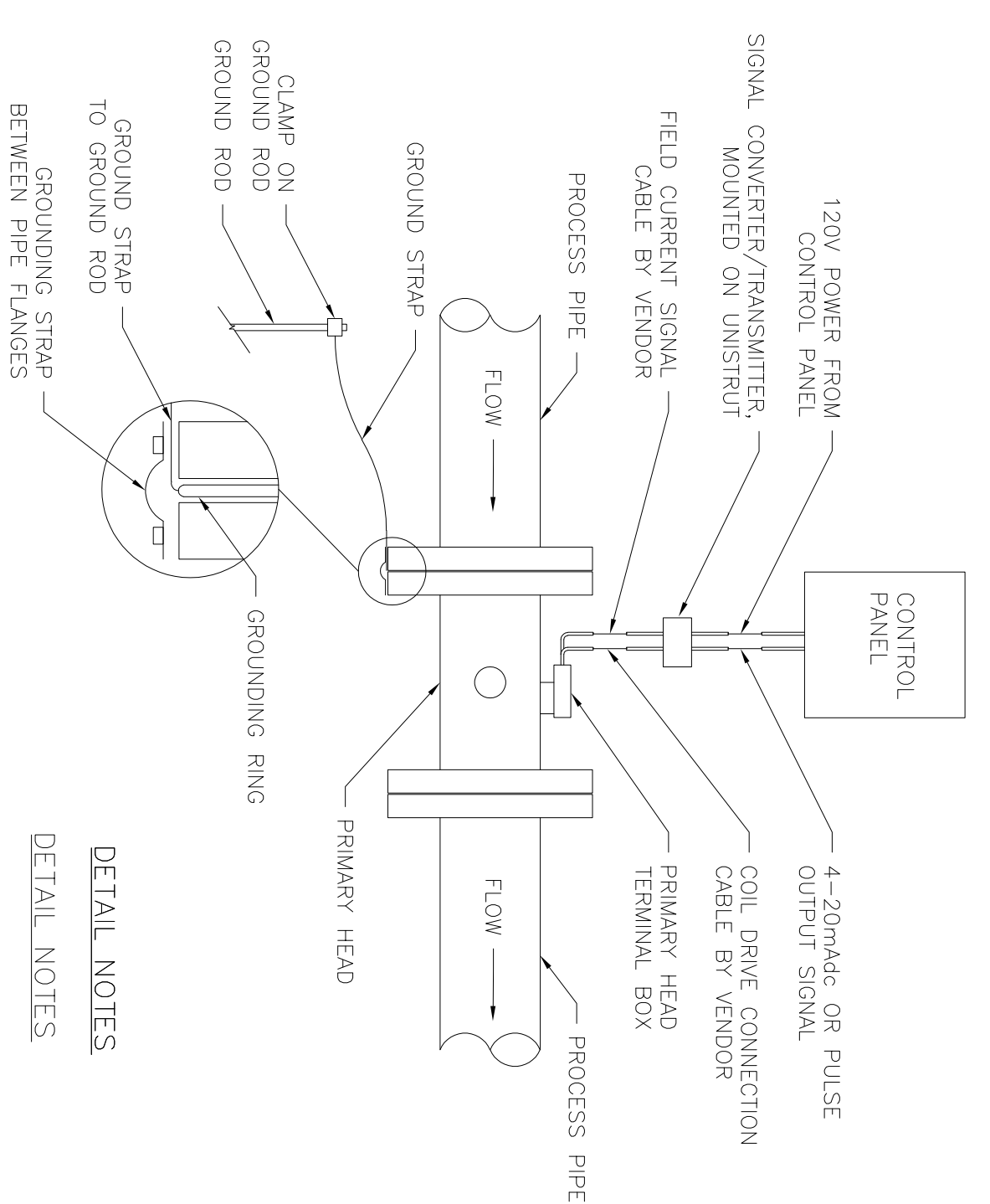

DETAIL NOTES

MAGNETIC FLOWMETER WITH REMOTE CONVERTER/TRANSMITTER DETAIL
SCALE: NONE

1. GROUND RESISTANCE SHALL BE LESS THAN 0.5 OHM AND LESS THAN 100 MILLIVOLT WHEN TESTED WITH STANDARD GROUND TESTING METHODS.
2. LENGTH OF COIL DRIVE AND FIELD CURRENT CABLES SHALL EXCEED MAXIMUM LENGTH AS DETERMINED BY EQUIPMENT MANUFACTURER.
3. INSTALL COIL DRIVE AND FIELD CURRENT CABLES IN SEPARATE 1" PVC COATED GALVANIZED RIGID STEEL CONDUITS.

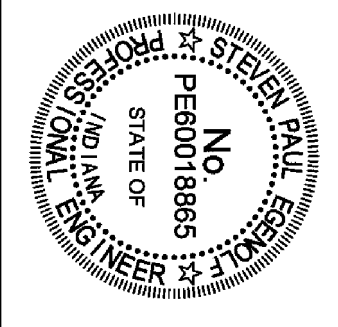

RECOMMENDED FOR APPROVAL	DESIGN ENGINEER	DATE
DESIGNED: SPE	DRAWN: SPE	05/31/19
CHECKED: SPE	CHECKED: SPE	

WHITE RIVER WELL #3
VOC REMOVAL
ELECTRICAL DETAILS

CEG PROJECT NUMBER	20MR02557
CONSULTANT PROJECT NUMBER	201800344
SHEET	E-2

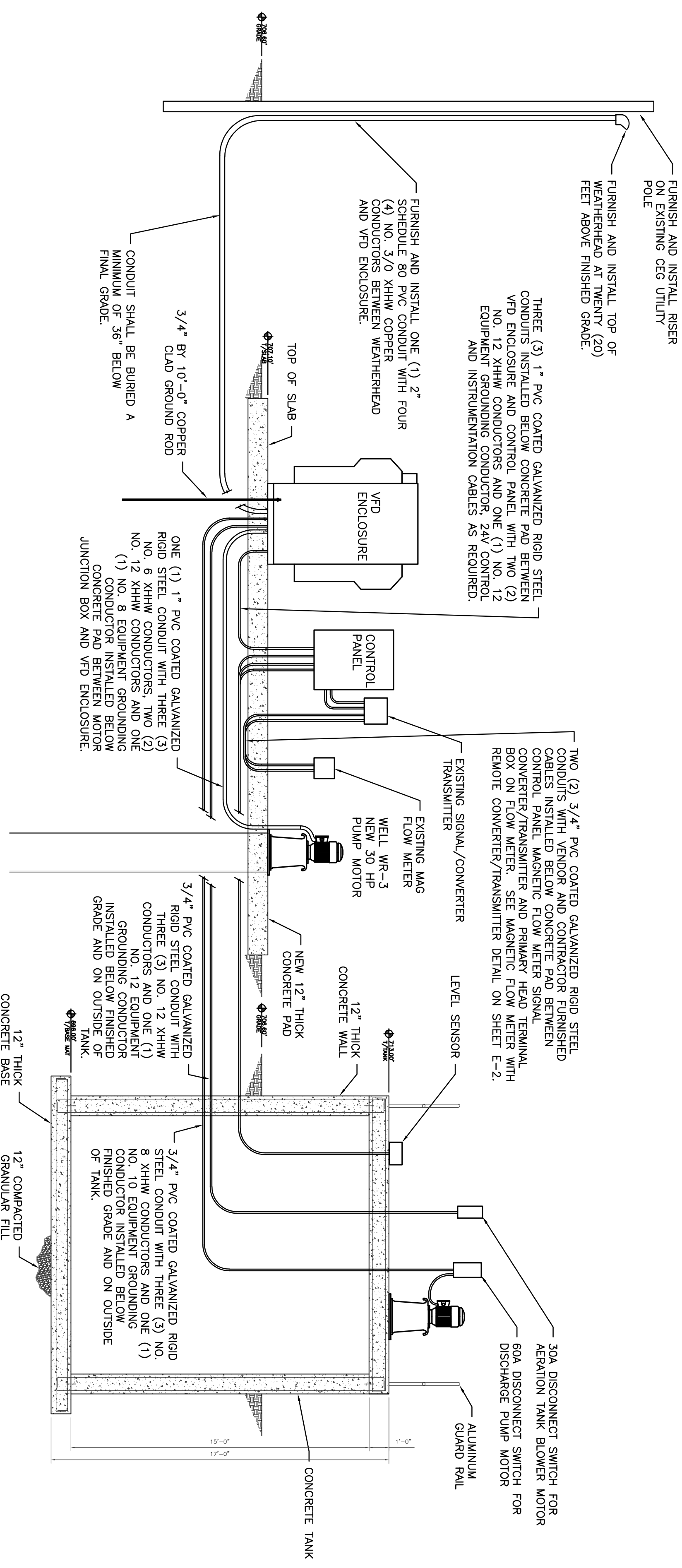

ELECTRICAL SINGLE LINE DIAGRAM
SCALE: NONE

ITEM QUAN	DESCRIPTION	PART NO.	MANUFACTURER
1	47"x32"x24" NEMA-4X, STAINLESS STEEL (304) ENCLOSURE WITH BACKPLANE. PROVIDE (2) SIDEWALLS (8700.680), BASE SIDES (8701.060) AND BASE FRONT/REAR (8701.800) PROVIDE STAINLESS STEEL, 1/4" BREATHER DRAIN COMBINATION.	8450.680	RITTAL
2	VFD, WITH ANALOG SPEED CONTROL, INPUT (4-20MA), DIGITAL START STOP AND DIGITAL OUTPUTS FOR FAULT AND MOTOR RUNNING.	30HP-VT130P9U4330	TOSHIBA
3	VFD, WITH ANALOG SPEED CONTROL, INPUT (4-20MA), DIGITAL START STOP AND DIGITAL OUTPUTS FOR FAULT AND MOTOR RUNNING.	20HP-VT130P9U4220	TOSHIBA
4	SOLID STATE SOFT STARTER, DIGITAL START STOP AND DIGITAL OUTPUTS FOR FAULT AND MOTOR RUNNING.	TE2-18-BP	TOSHIBA
5	AIR CONDITIONER. (7507BTU) 2.2KW/HR, 480V, 3 PHASE, NEMA-4X.	3328.540	RITTAL
6	DISCONNECT SWITCH, FUSED, NEMA-4X HANDLE (194R-1M4), DEFERRABLE, 3 PHASE, 480V, 200A, ONE POLE AND SHIRT, FINGER SAFE TERMINAL COVERS, AND ANY OTHER NECESSARY ACCESSORIES.	194R-1200-1753	ALLEN-BRADLEY
7	BREAKERS, 480V, 3 POLE, 30A, 20A AND 10A, 2 POLE, 10A.	1492-SM2BXXX 1492-SM2B100	ALLEN-BRADLEY
8	BREAKERS, 120V, 1 POLE, 30A, 15A, 10A, 4A, 1A.	1492-SM1BXX	ALLEN-BRADLEY
9	BREAKERS, 480V, 3 POLE, 100A, 70A, 1 POLE 20 GFCI	HLL36100 HLL36070	SQUARE D
10	CONTROL POWER TRANSFORMER, 3000VA, 480V-120V.	1497B-M14-O-N	ALLEN-BRADLEY
11	TVSS, 480V, 3 PHASE	PTE160 37201	EATON
12	RECEPTACLE, BOX AND COVER ASSEMBLY	FA-RECS	AUTOMATION DIRECT
13	HEATER 63-75 WATT, 110V - 240V, SINGLE PHASE 50/60 HZ THERMOSTAT 24V - 240V AC, 5 TO 60 DEGREES CENINGRADE	3105.350 AND 3110.00	RITTAL
14	ELAPSED TIME METER	ES-224-C0448	EATON
15	GROUPED BUS BAR		ALLEN-BRADLEY

NOTE: ITEM 2: VFDS SHALL BE SUPPLIED AS INDICATED. ALL ELSE SHALL BE SUPPLIED AS INDICATED OR OWNER APPROVED EQUIP.

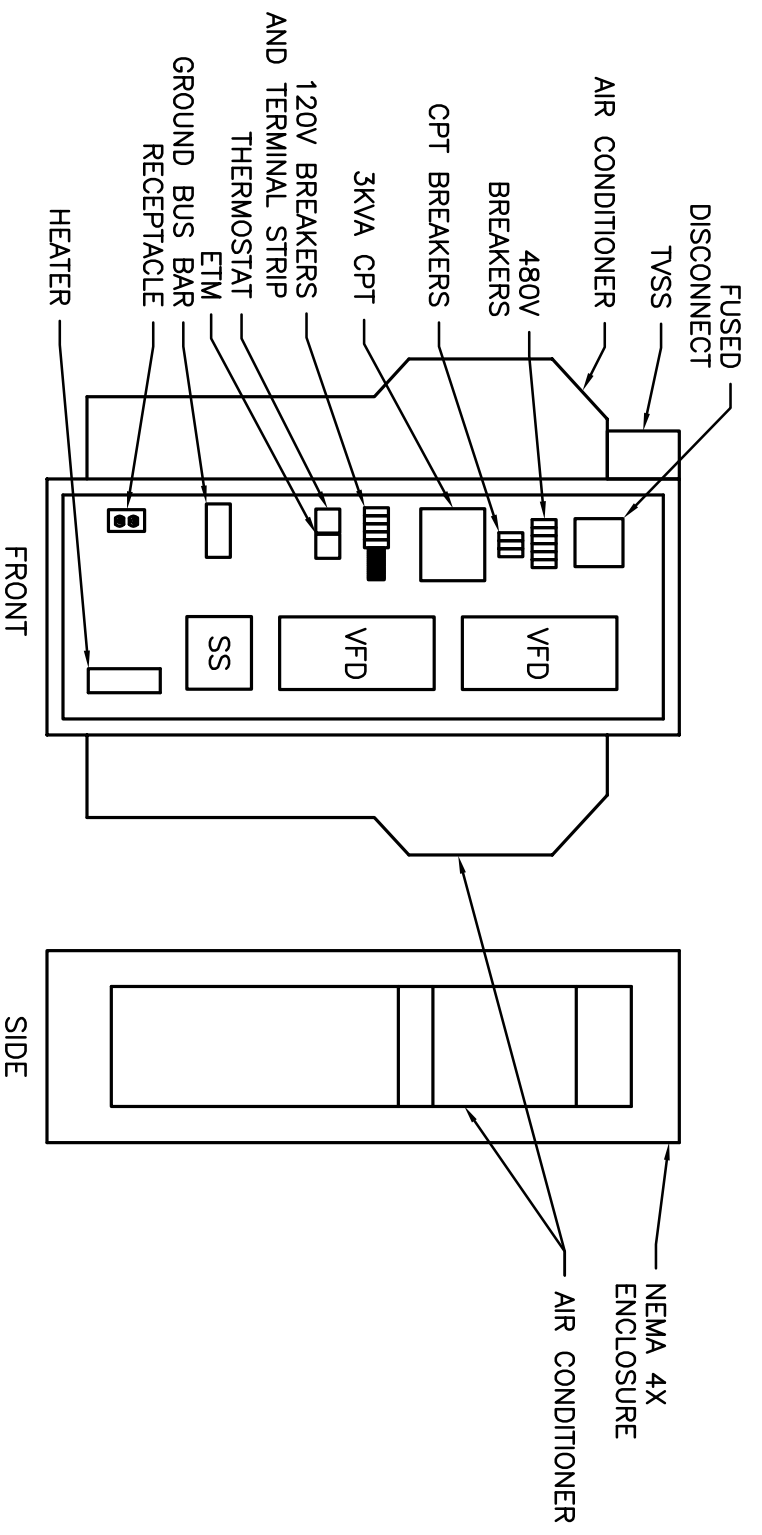

VFD ENCLOSURE DETAILS
SCALE: NONE

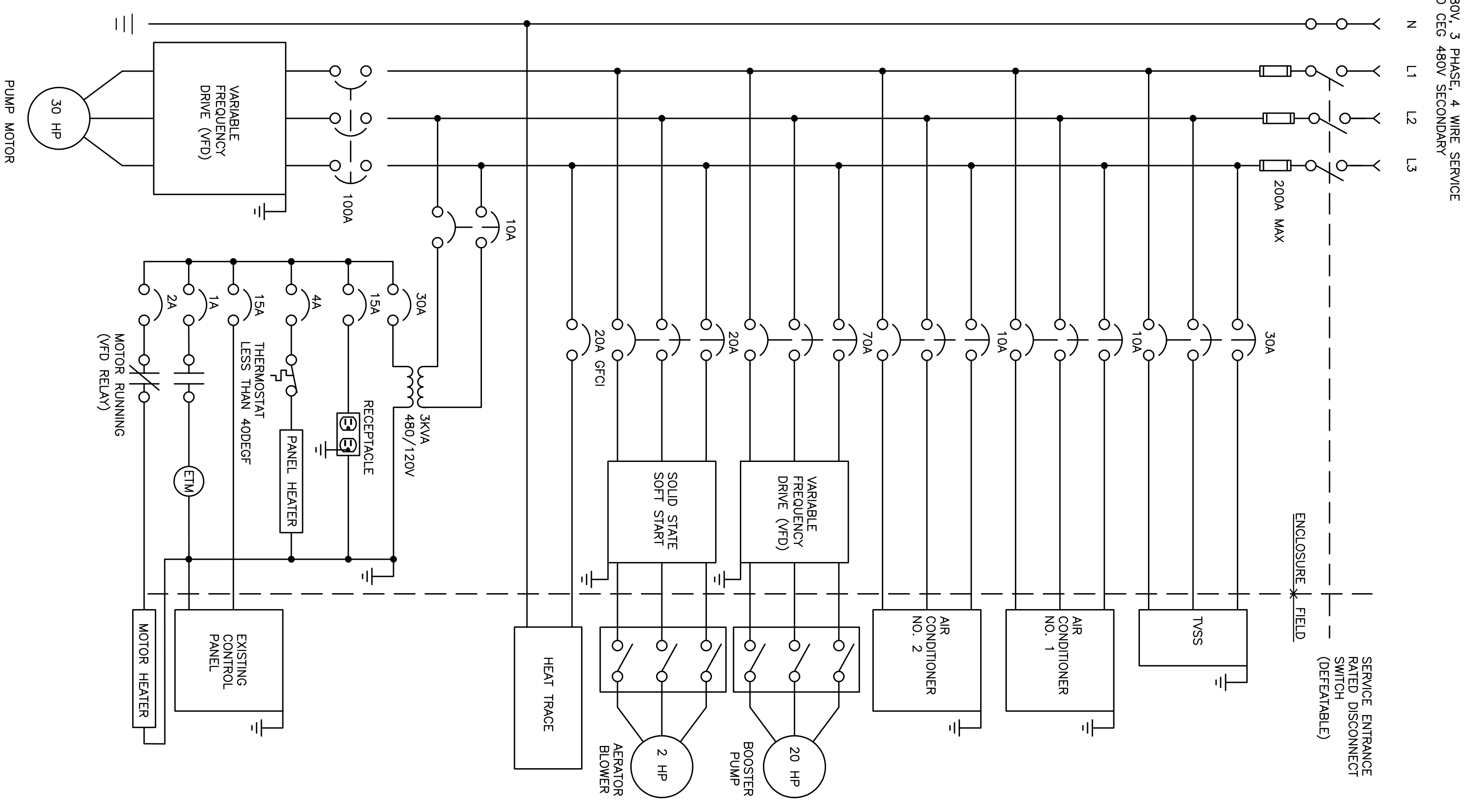

VFD SCHEMATIC DIAGRAM
SCALE: NONE

DATE	REVISION	BY

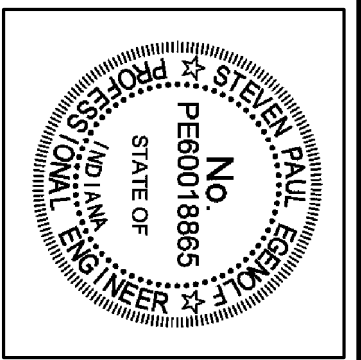

DESIGNED: SPE	DRAWN: SPE	CHECKED: SPE
RECOMMENDED FOR APPROVAL	DESIGN ENGINEER	DATE
	<i>Steven P. Paul</i>	05/31/19

WHITE RIVER WELL #3
VOC REMOVAL
SINGLE LINE DIAGRAM, SCHEMATIC AND PANEL ELEVATION

CEG PROJECT NUMBER	20WR02557
CONSULTANT PROJECT NUMBER	201800344
SHEET	E-3

WHITE RIVER TREATMENT
PLANT
MAIN TREATMENT BLDG

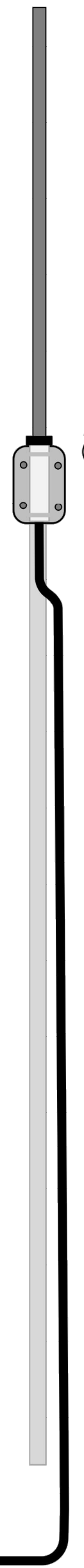
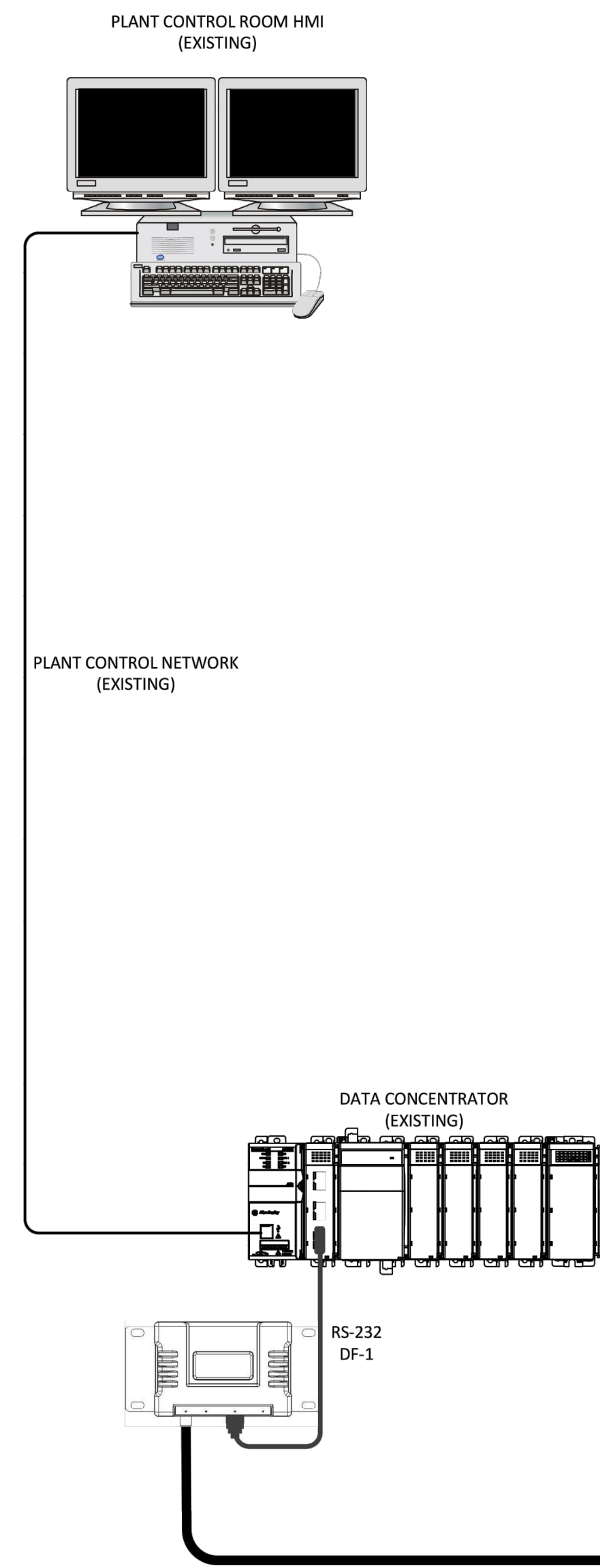

FIELD

PLANTWIDE DF-1 WIRELESS
NETWORK
(EXISTING)

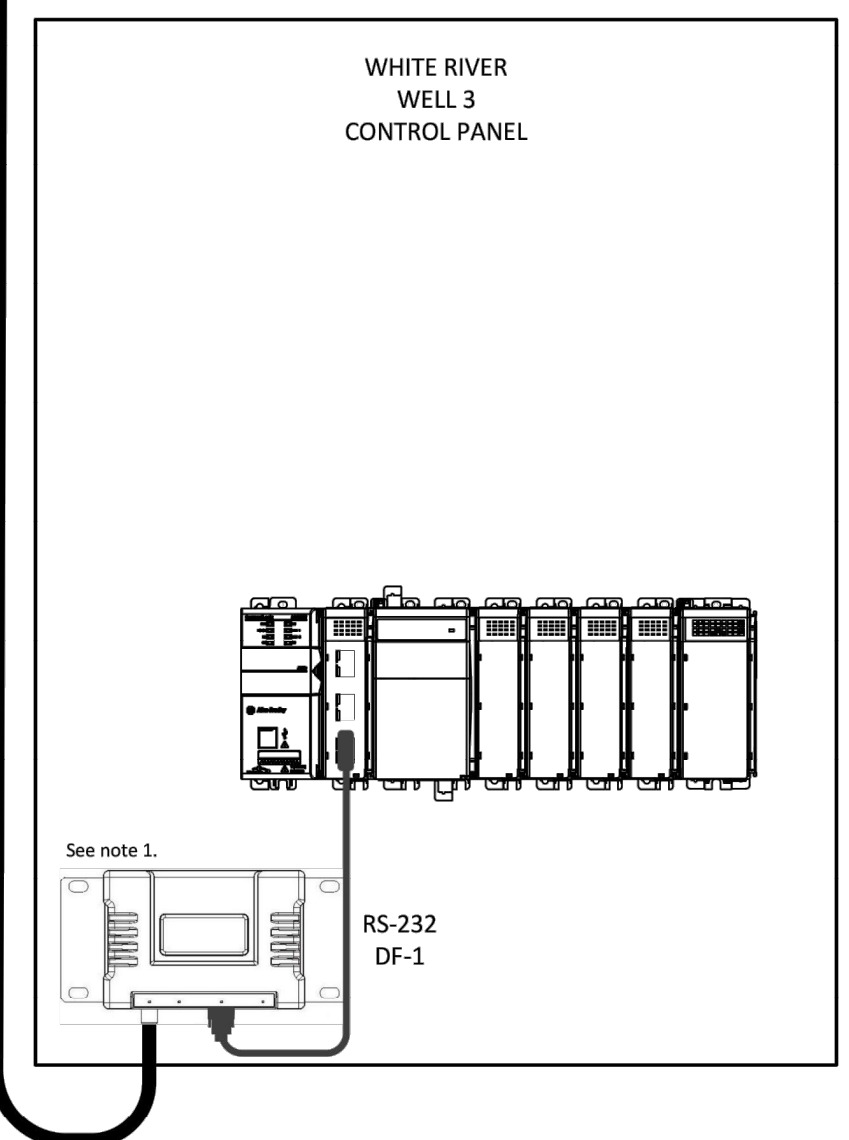
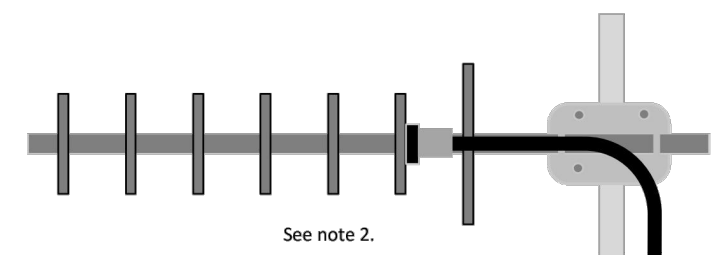

- Notes:
1. Reuse existing Well 3 radio. Coordinate with Owner for station address and memory assignments in existing data concentrator.
 2. Align antenna for maximum RSSI. Verify minimum of 20 dB fade margin above radio sensitivity.

PLOT SCALE: 0.5"=1'-0" DATE: 5/4/2019 1:25 PM EDITED BY: jgiffith PATH: C:\2018\20180344\1_00344.dwg

REVISIONS		
DATE	REVISION	BY



RECOMMENDED FOR APPROVAL	DESIGN ENGINEER	5/31/2019	DATE
DESIGNED: CC	DRAWN: CC		
CHECKED: CC	CHECKED: CC		

**WHITE RIVER WELL #3
VOC REMOVAL**

SYSTEM DIAGRAM

CEG PROJECT NUMBER	20WR02557
CONSULTANT PROJECT NUMBER	201800344
SHEET	I-1

ITEM	MANUFACTURER	PART NUMBER	DESCRIPTION
1	ALLEN BRADLEY	1769-ECR	Right End Cap Terminator
2	ALLEN BRADLEY	1769-IF8	8 Channel Analog Voltage/Current Input Module
3	ALLEN BRADLEY	1769-IQ16	16 Point 24 VDC Sinking/Sourcing Input Module
4	ALLEN BRADLEY	1769-L30ER	CompactLogix 5370 L3 Controller
5	ALLEN BRADLEY	1769-OB8	8 Point High Power 24 VDC Output Module
6	ALLEN BRADLEY	1769-OF4	4 Channel Analog Current/Voltage Output Module
7	ALLEN BRADLEY	1769-PA4	120/240V AC Power Supply (5V @ 4 Amp)
8	ALLEN BRADLEY	199-DR1	DIN Rail
9	ALLEN BRADLEY	800T-J2A	3 POS Selector Switch
10	ALLEN BRADLEY	800T-Q24G	Green Indicator Lamp
11	ALLEN BRADLEY	800T-U29	10K Potentiometer
12	ANDREWS	LDF4-50A	Coaxial Cable with N Male Connectors
13	HOFFMAN	A483616SSLP	Wall Mount Enclosure, NEMA 4x
14	HOFFMAN	A48P36	Panel
15	HOFFMAN	DFK	Swingout Panel Kit
16	HOFFMAN	DAH1001A	Panel Heater
17	MDS	973194A14C	Clearwave 10dBi YAGI Antenna / mounting hardware
18	PANDUIT	C2WH6	2W Duct Cover
19	PANDUIT	G2X4WH6	2X4 Wire Duct
20	PHOENIX CONTACT	800886	End Clamp
21	PHOENIX CONTACT	2864176	MINI MCR-SL-UI-2I-NC Signal Isolator
22	PHOENIX CONTACT	2838186	TT-2-PE-24DC Surge Protection Device
23	PHOENIX CONTACT	2904598	QUINT4-PS/1AC/24VDC/2.5 2.5A Power Supply
24	PHOENIX CONTACT	2907918	PLT-SEC-T3-120-FM-UT Surge Device
25	PHOENIX CONTACT	2967073	PLC-RSC-24UC/21-21 24VDC Relay
26	PHOENIX CONTACT	2900304	PLC-RPT-120UC/21 120VAC Relay
27	PHOENIX CONTACT	3214362	UT 4-L/L Two Level Feed-through Terminal Block
28	PHOENIX CONTACT	3044102	UT 4 Single Level Feed-through Terminal Block
29	PHOENIX CONTACT	3046537	UT 4-HESILED 24 VDC Blue Fused Terminal Block
30	PHOENIX CONTACT	3047028	End Cover
31	PHOENIX CONTACT	3047167	Partition Plate
32	PROSOFT	MVI69-DFCM	DF-1 Communications Module
33	POLYPHASER	IS-B50LN-C0-MA	Coax Surge Protector
34	RED LION	PAXP0010	Process Meter
35	SCHNIEDER ELECTRIC	9080GCB50	5 Amp Circuit Breaker
36	SCHNIEDER ELECTRIC	QUO115	15 Amp Circuit Breaker
37	TIME MARK	300-L	Time Delay Relay

PLOT SCALE:0.3889:1 EDT DATE:5/4/2019 1:26 PM EDITED BY:gyffhsh PATH:C:\2018\2018_03\4\1 - drawings\environmental\201803344_eu_bk.ctb.dwg

REVISIONS		
DATE	REVISION	BY



RECOMMENDED FOR APPROVAL	DESIGN ENGINEER	DATE
		5/31/2019
DESIGNED: CC	DRAWN: CC	
CHECKED: CC	CHECKED: CC	

WHITE RIVER WELL #3 VOC REMOVAL	CEG PROJECT NUMBER
	20WR02557
BILL OF MATERIAL	CONSULTANT PROJECT NUMBER
	201800344
	SHEET
	1-2

PLOT SCALE: 0.3889:1 EDT DATE: 5/4/2019 1:25 PM EDITED BY: jgiffith PATH: C:\2018\20180344\1_drawing\environmental\20180344_epl\sketch.dwg

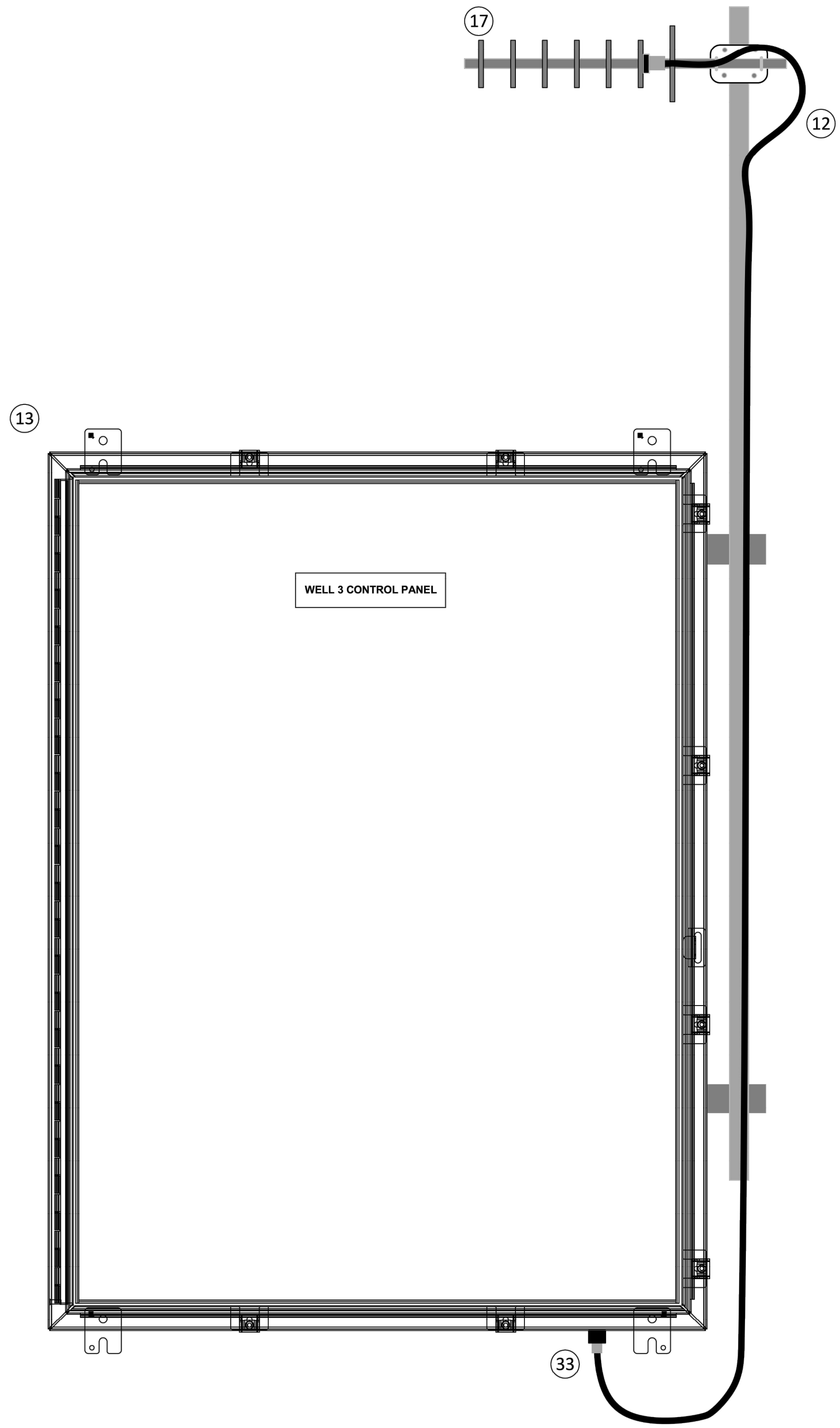

REVISIONS		
DATE	REVISION	BY



RECOMMENDED FOR APPROVAL	DESIGN ENGINEER	DATE
		5/31/2019
DESIGNED: CC	DRAWN: CC	
CHECKED: CC	CHECKED: CC	

**WHITE RIVER WELL #3
VOC REMOVAL**

PLC ENCLOSURE

CEG PROJECT NUMBER	20WR02557
CONSULTANT PROJECT NUMBER	201800344
SHEET	1-3

SWINGOUT PANEL

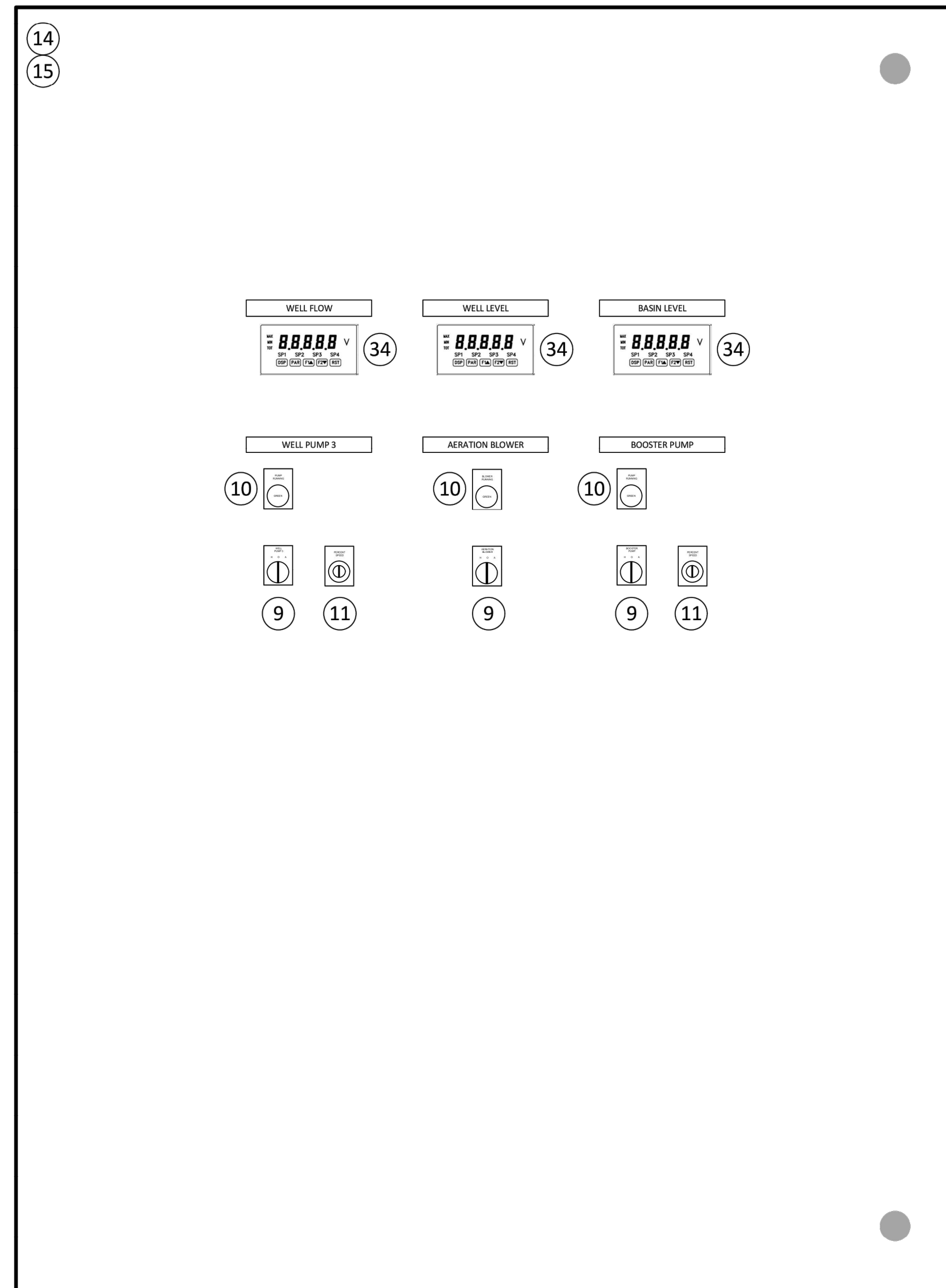

BACKPANEL

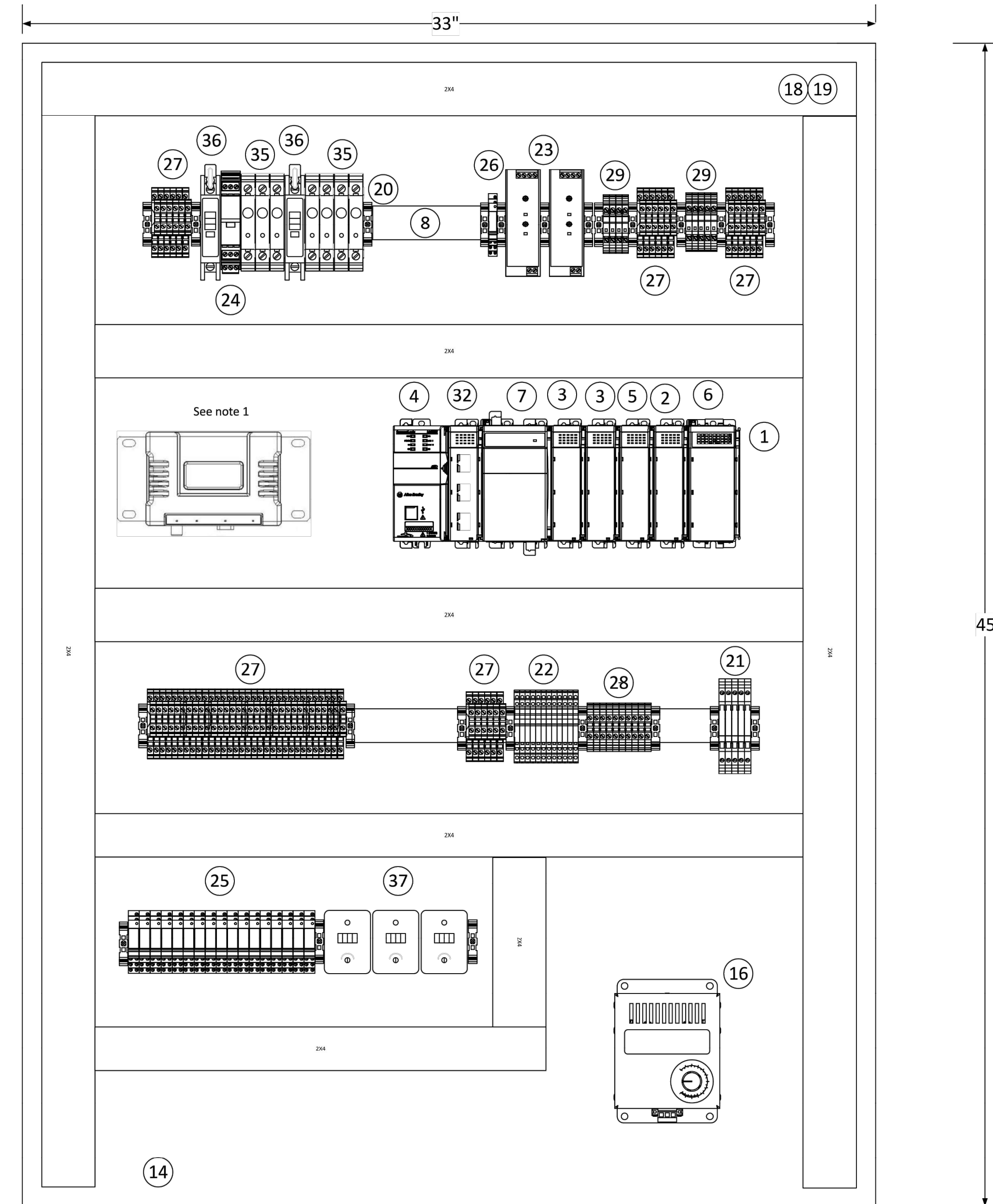

PLOT SCALE: 0.3889:1 EDT DATE: 5/4/2019 1:25 PM EDITED BY: jgiffith PARTS: 201800344.dwg DRAWING: environment\201800344.dwg

REVISIONS		
DATE	REVISION	BY



RECOMMENDED FOR APPROVAL	DESIGN ENGINEER	DATE
		5/31/2019
DESIGNED: CC	DRAWN: CC	
CHECKED: CC	CHECKED: CC	

WHITE RIVER WELL #3 VOC REMOVAL
PLC BACK PANEL LAYOUT

CEG PROJECT NUMBER	20WR02557
CONSULTANT PROJECT NUMBER	201800344
SHEET	I-4

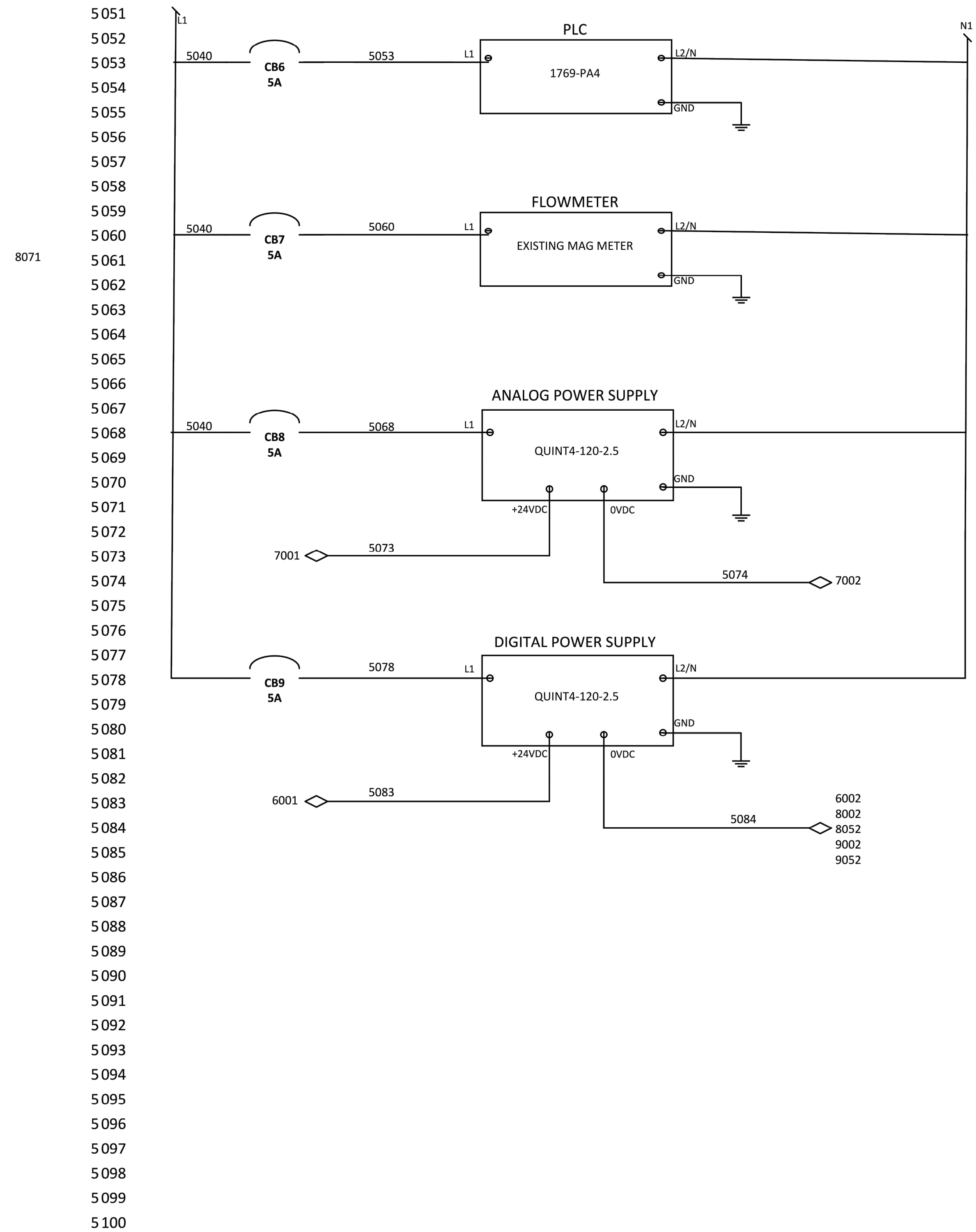
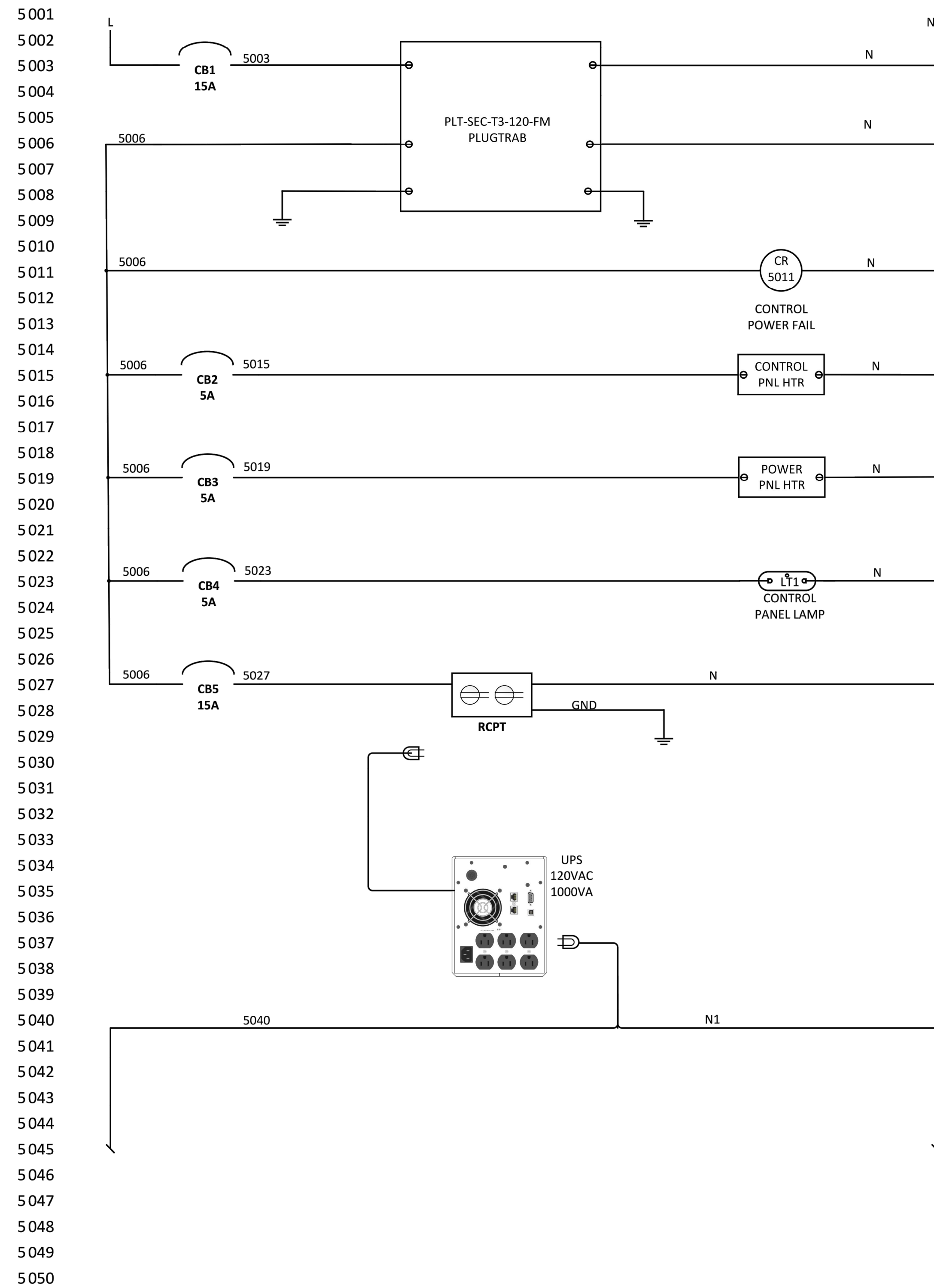

P:\01_SALES\38691_EDIT_DATE\4/2019_1:26 PM_EDITED_BY\jgiffith_PATHEP_2018\00344.dwg @energy_environments\20180334.dwg:ksf.dwg

REVISIONS		
DATE	REVISION	BY



RECOMMENDED FOR APPROVAL	5/31/2019
DESIGN ENGINEER	DATE
DESIGNED: CC	DRAWN: CC
CHECKED: CC	CHECKED: CC

WHITE RIVER WELL #3 VOC REMOVAL
120 VAC POWER DISTRIBUTION

CEG PROJECT NUMBER	20WR02557
CONSULTANT PROJECT NUMBER	201800344
SHEET	I-5

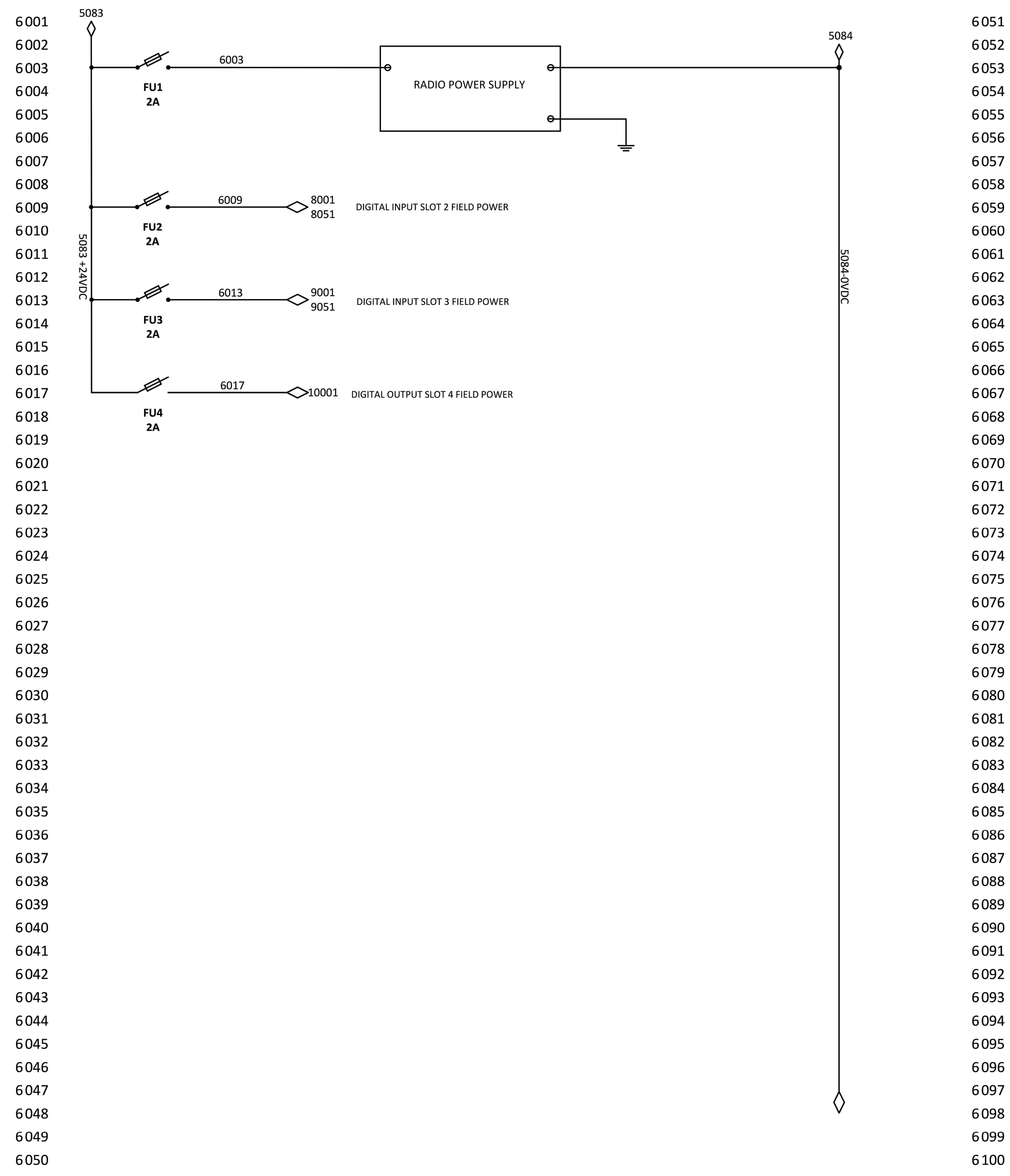

PLOT SCALE: 0.3889:1 E:\PROJECTS\4\2019_1\25 PM EDITED BY: jgiffith PATH: C:\Users\jgiffith\Documents\201803344\201803344.dwg

REVISIONS		
DATE	REVISION	BY



RECOMMENDED FOR APPROVAL	DESIGN ENGINEER	DATE
		5/31/2019
DESIGNED: CC	DRAWN: CC	
CHECKED: CC	CHECKED: CC	

**WHITE RIVER WELL #3
VOC REMOVAL**

24 VDC DIGITAL POWER DISTRIBUTION

CEG PROJECT NUMBER	20WR02557
CONSULTANT PROJECT NUMBER	201800344
SHEET	I-6

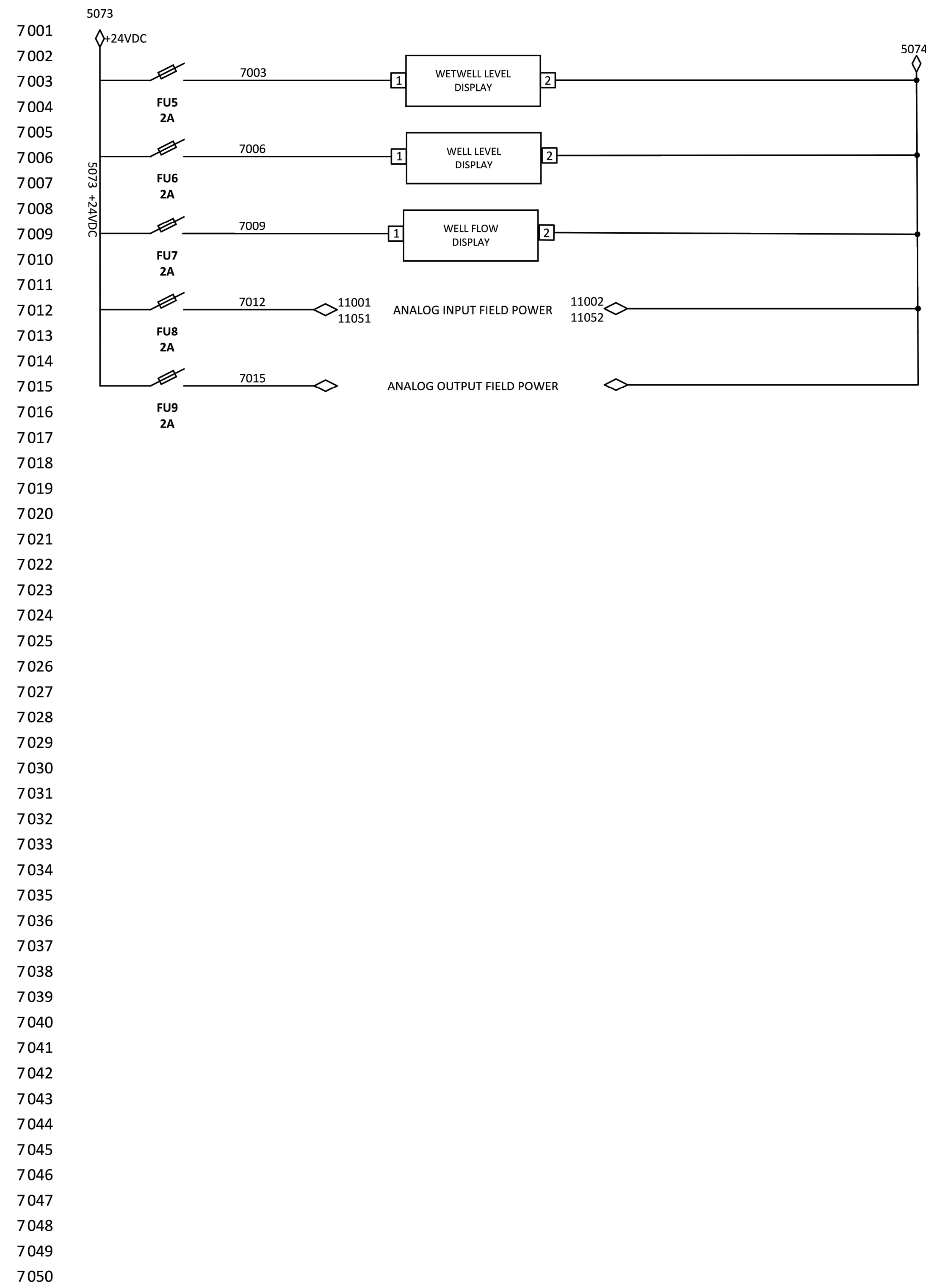

7001
7002
7003
7004
7005
7006
7007
7008
7009
7010
7011
7012
7013
7014
7015
7016
7017
7018
7019
7020
7021
7022
7023
7024
7025
7026
7027
7028
7029
7030
7031
7032
7033
7034
7035
7036
7037
7038
7039
7040
7041
7042
7043
7044
7045
7046
7047
7048
7049
7050

7051
7052
7053
7054
7055
7056
7057
7058
7059
7060
7061
7062
7063
7064
7065
7066
7067
7068
7069
7070
7071
7072
7073
7074
7075
7076
7077
7078
7079
7080
7081
7082
7083
7084
7085
7086
7087
7088
7089
7090
7091
7092
7093
7094
7095
7096
7097
7098
7099
7100

PLOT SCALE: 0.3889:1 E:\PROJECTS\4\2019_1\25 PM EDITED: 5/31/2019 1:25 PM EDITED: 5/31/2019 1:25 PM EDITED: 5/31/2019 1:25 PM

REVISIONS		
DATE	REVISION	BY



RECOMMENDED FOR APPROVAL	DESIGN ENGINEER	DATE
		5/31/2019
DESIGNED: CC	DRAWN: CC	
CHECKED: CC	CHECKED: CC	

**WHITE RIVER WELL #3
VOC REMOVAL**

24 VDC ANALOG POWER DISTRIBUTION

CEG PROJECT NUMBER	20WR02557
CONSULTANT PROJECT NUMBER	201800344
SHEET	1-7

PLOT SCALE: 0.3889:1 EDT DATE: 5/4/2019 1:25 PM EDITED BY: jgiffith PATH: C:\Users\jgiffith\Documents\201803344.dwg

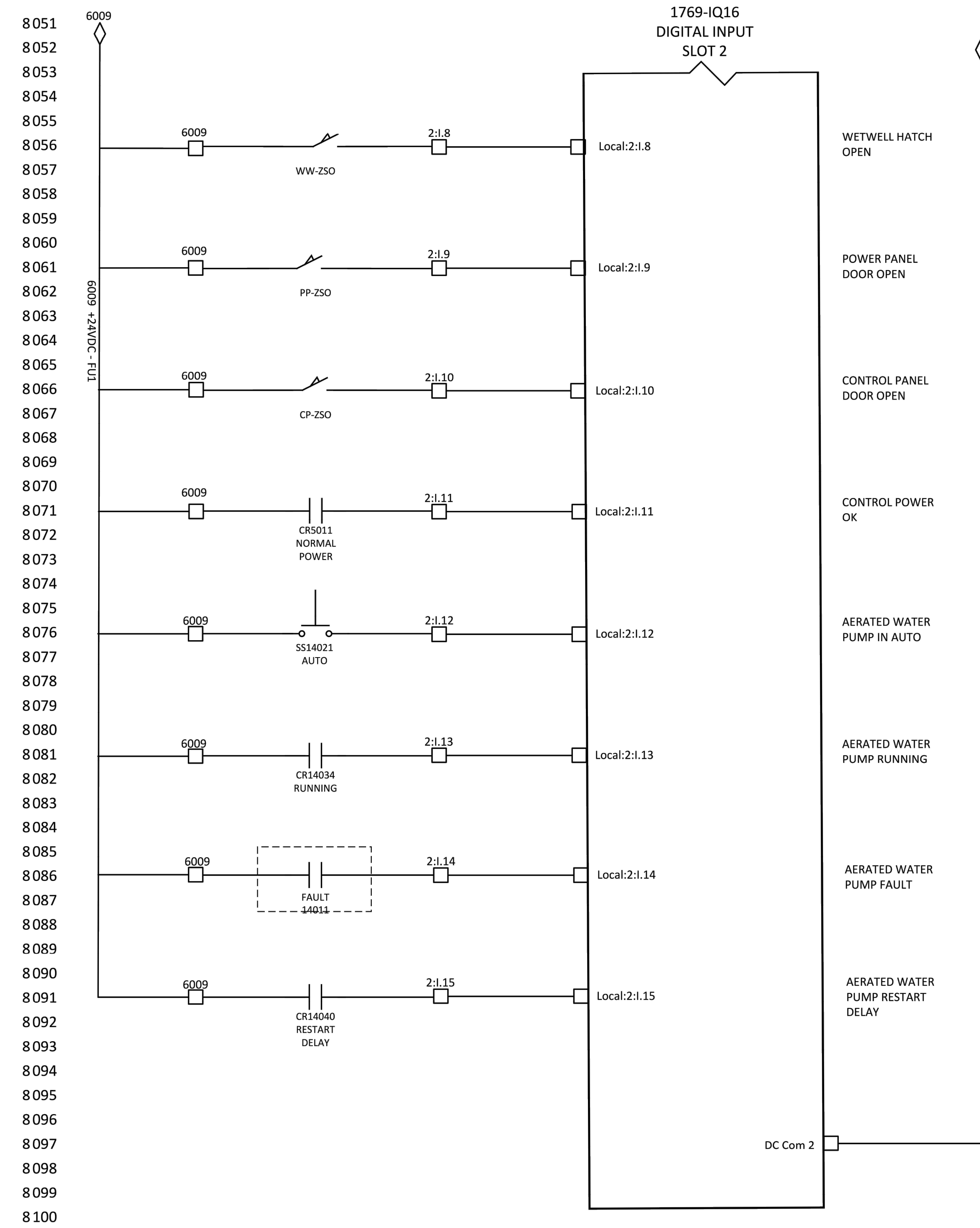
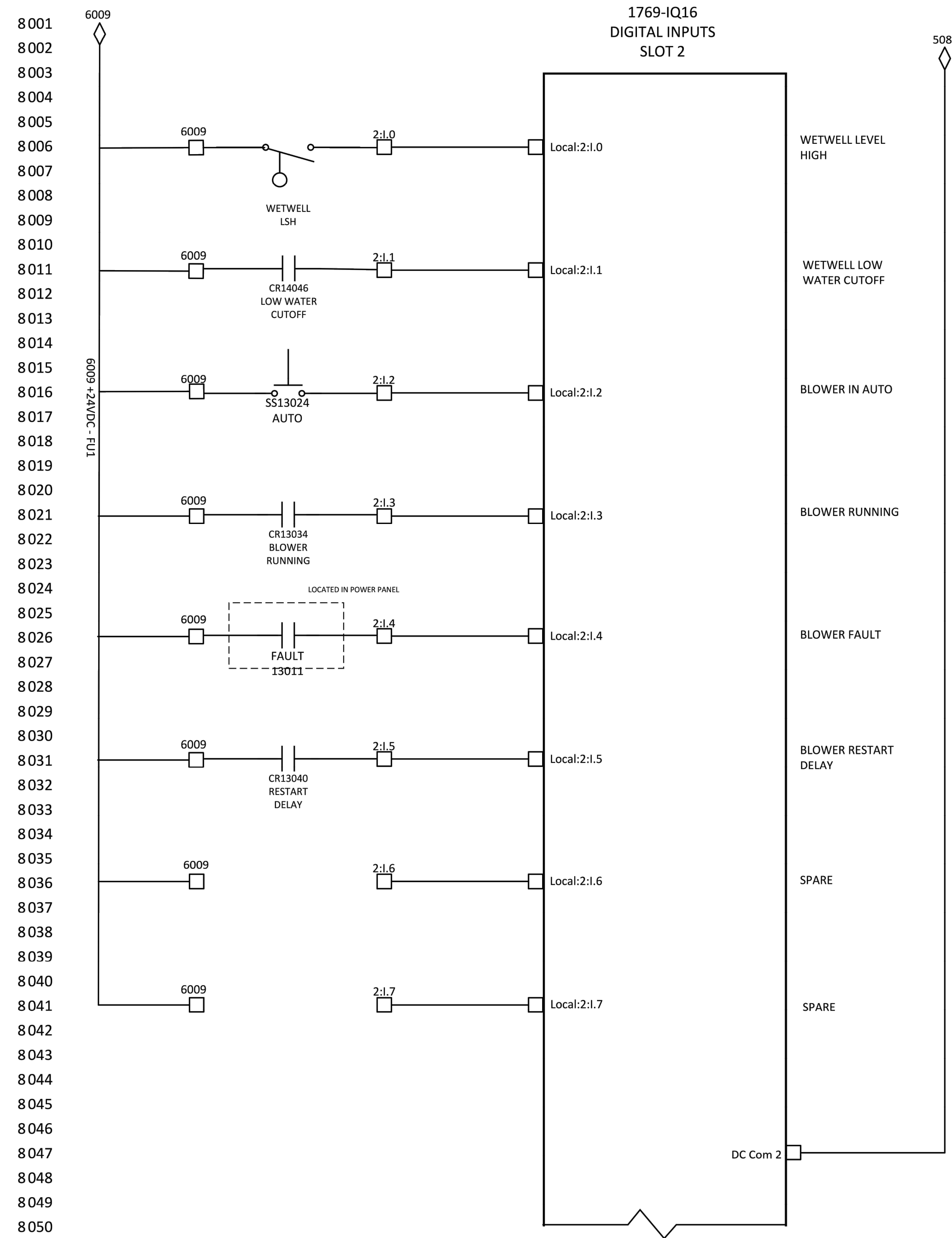

REVISIONS		
DATE	REVISION	BY



RECOMMENDED FOR APPROVAL	DESIGN ENGINEER	DATE
		5/31/2019
DESIGNED: CC	DRAWN: CC	
CHECKED: CC	CHECKED: CC	

WHITE RIVER WELL #3
VOC REMOVAL
DIGITAL INPUTS

CEG PROJECT NUMBER	20WR02557
CONSULTANT PROJECT NUMBER	201800344
SHEET	I-8

PLOT SCALE: 0.3889:1 EDIT DATE: 5/4/2019 1:25 PM EDITED BY: jgiffith PATH: C:\2018\201800344\1_ drawings\environmental\201800344_e\i_bk.dwg

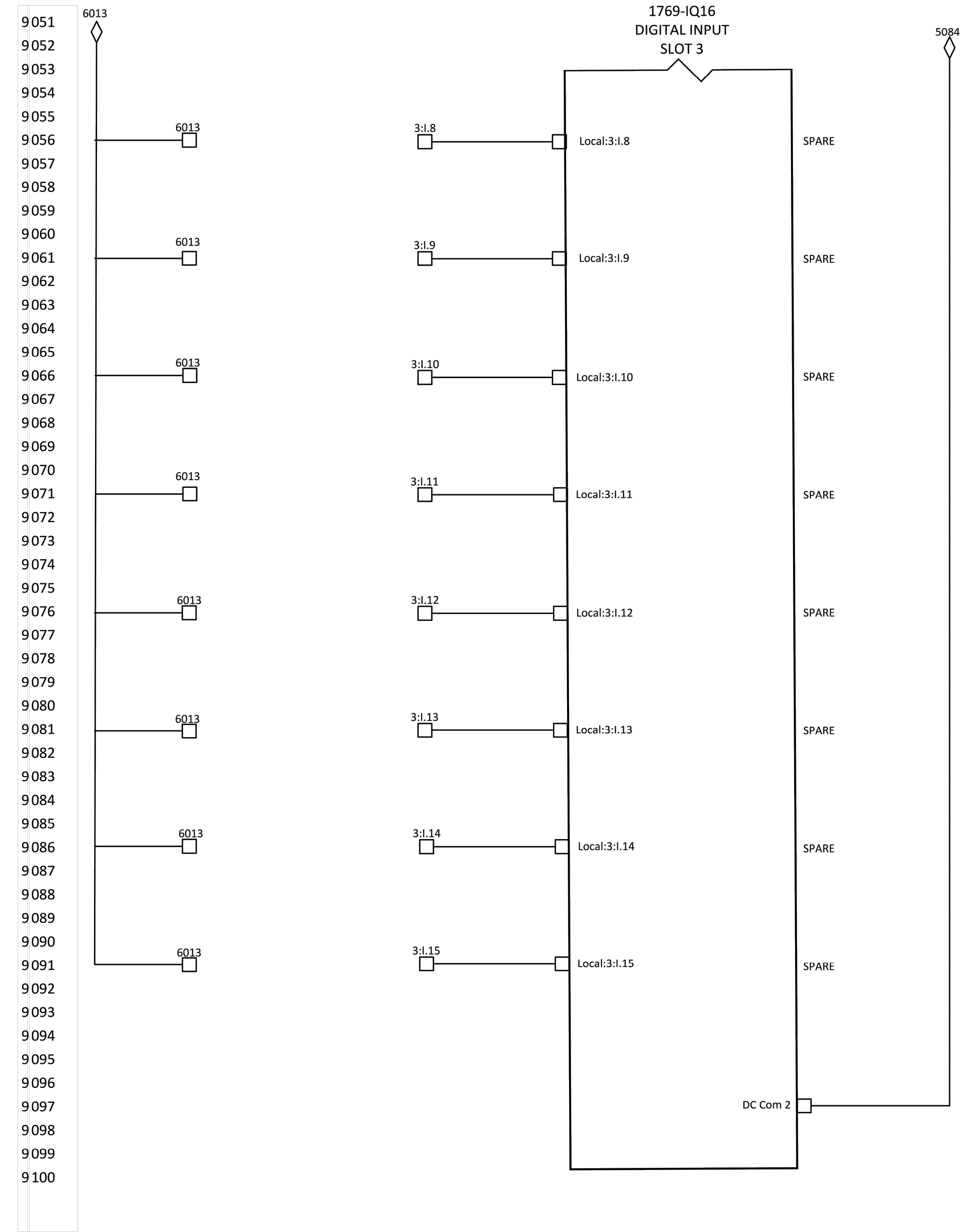
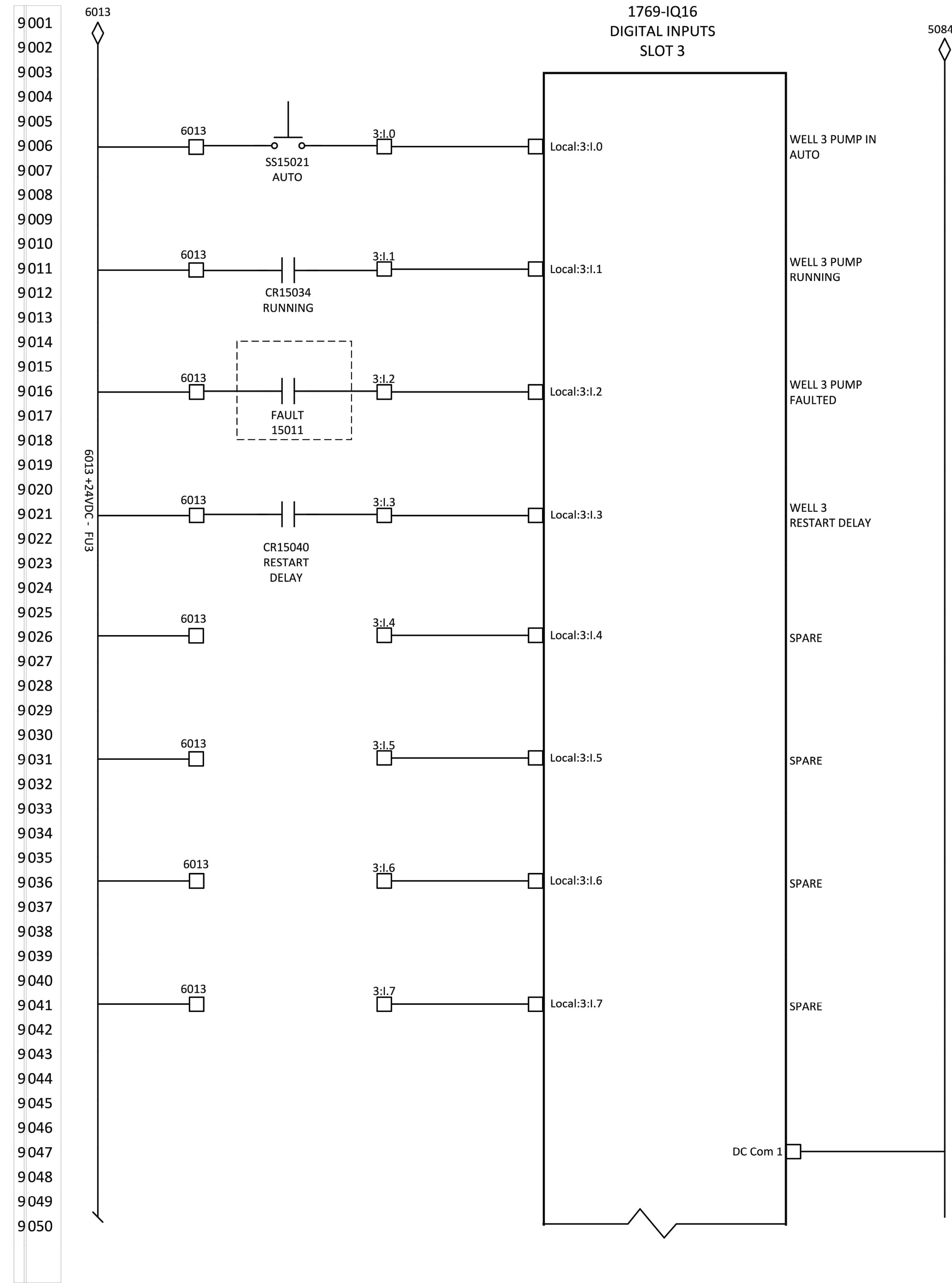

REVISIONS		
DATE	REVISION	BY



RECOMMENDED FOR APPROVAL	DESIGN ENGINEER	DATE
		5/31/2019
DESIGNED: CC	DRAWN: CC	
CHECKED: CC	CHECKED: CC	

WHITE RIVER WELL #3
VOC REMOVAL
DIGITAL INPUTS

CEG PROJECT NUMBER	20WR02557
CONSULTANT PROJECT NUMBER	201800344
SHEET	1-9

PLOT SCALE: 0.3889:1 E:\PROJECTS\4\2019\1-25 PM EDITED BY: jgiffith PATH: C:\Users\jgiffith\Documents\201803344\201803344.dwg

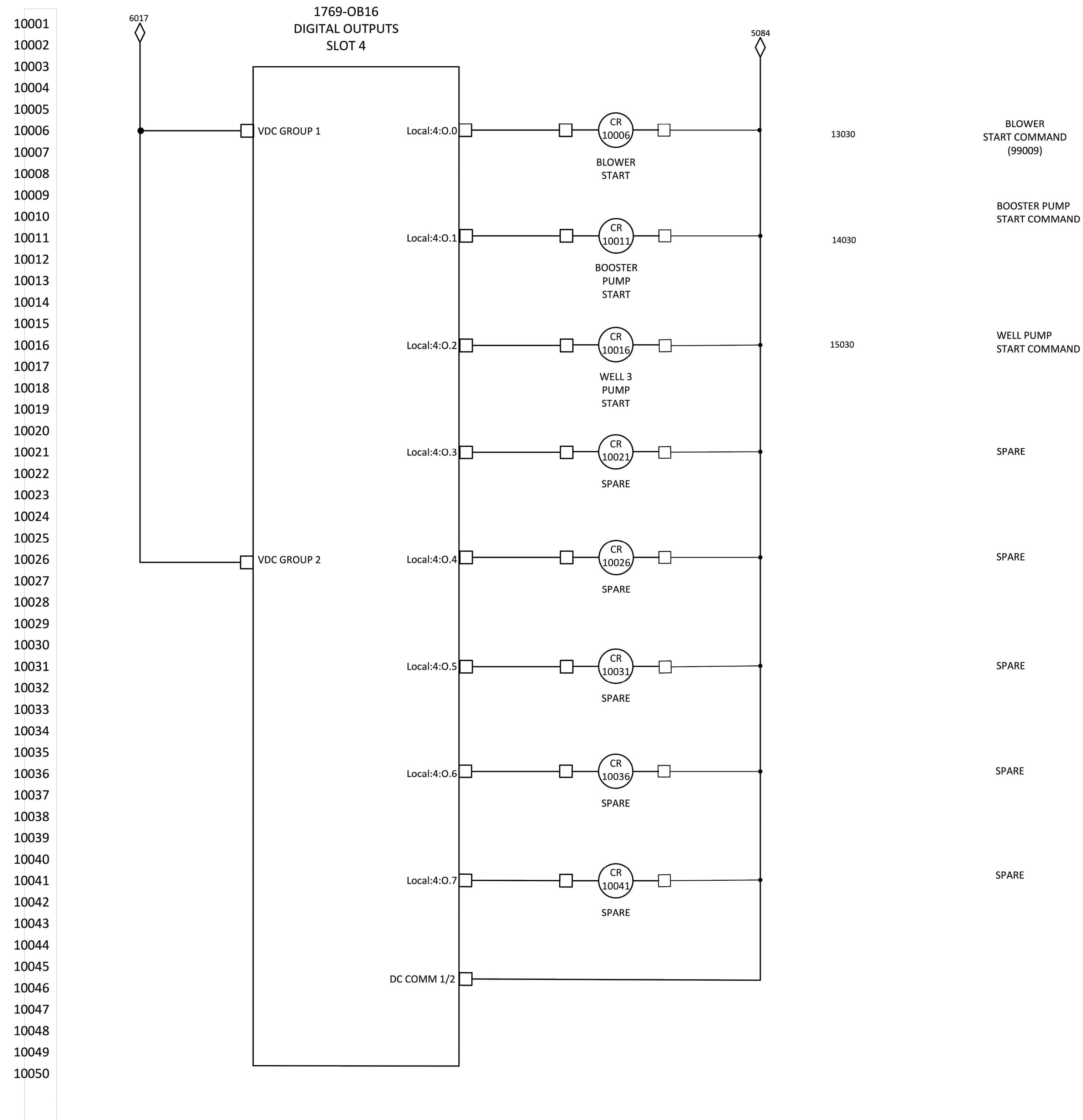

REVISIONS		
DATE	REVISION	BY



RECOMMENDED FOR APPROVAL	DESIGN ENGINEER	DATE
		5/31/2019
DESIGNED: CC	DRAWN: CC	
CHECKED: CC	CHECKED: CC	

WHITE RIVER WELL #3 VOC REMOVAL
DIGITAL OUTPUTS

CEG PROJECT NUMBER	20WR02557
CONSULTANT PROJECT NUMBER	201800344
SHEET	I-10

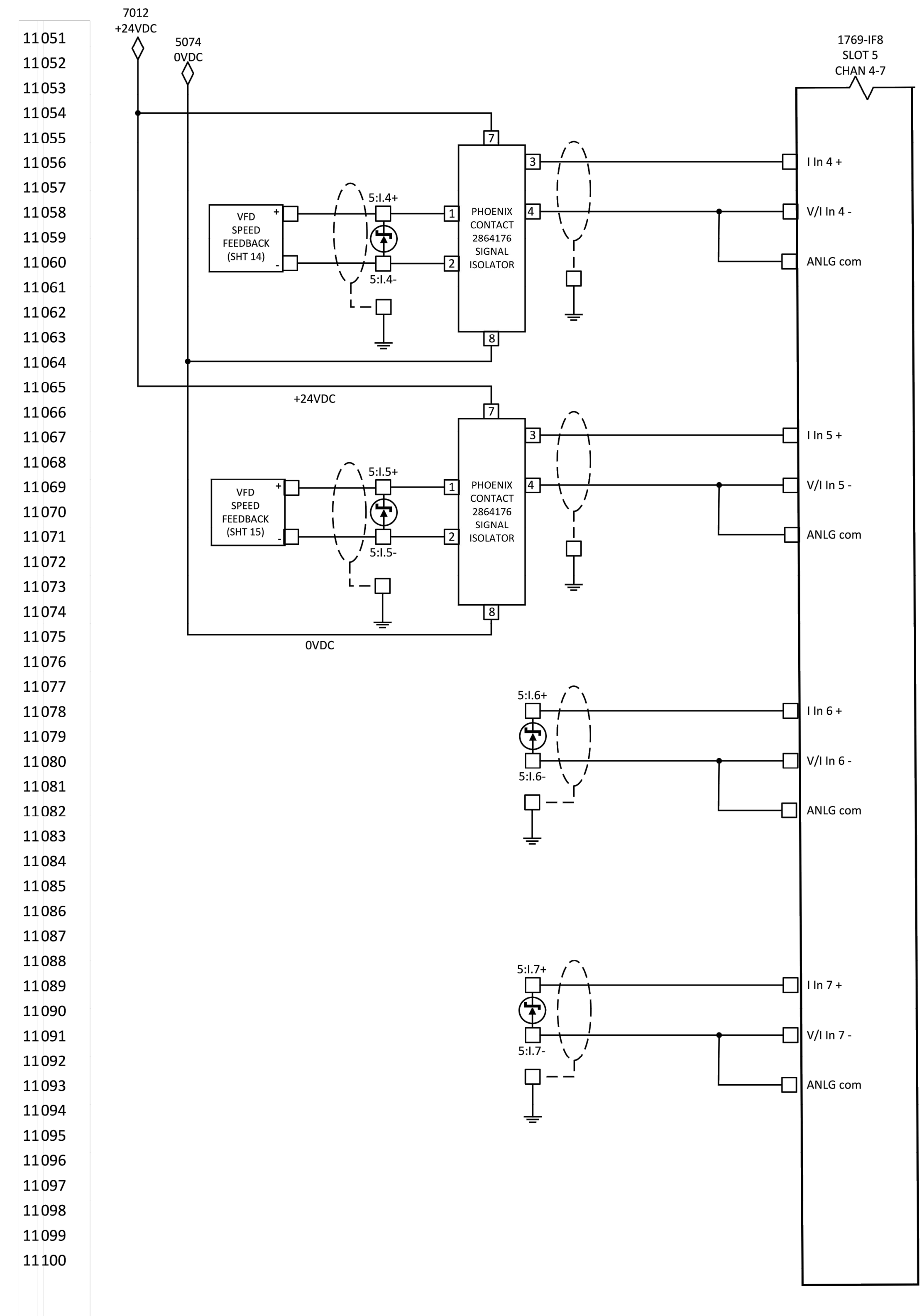
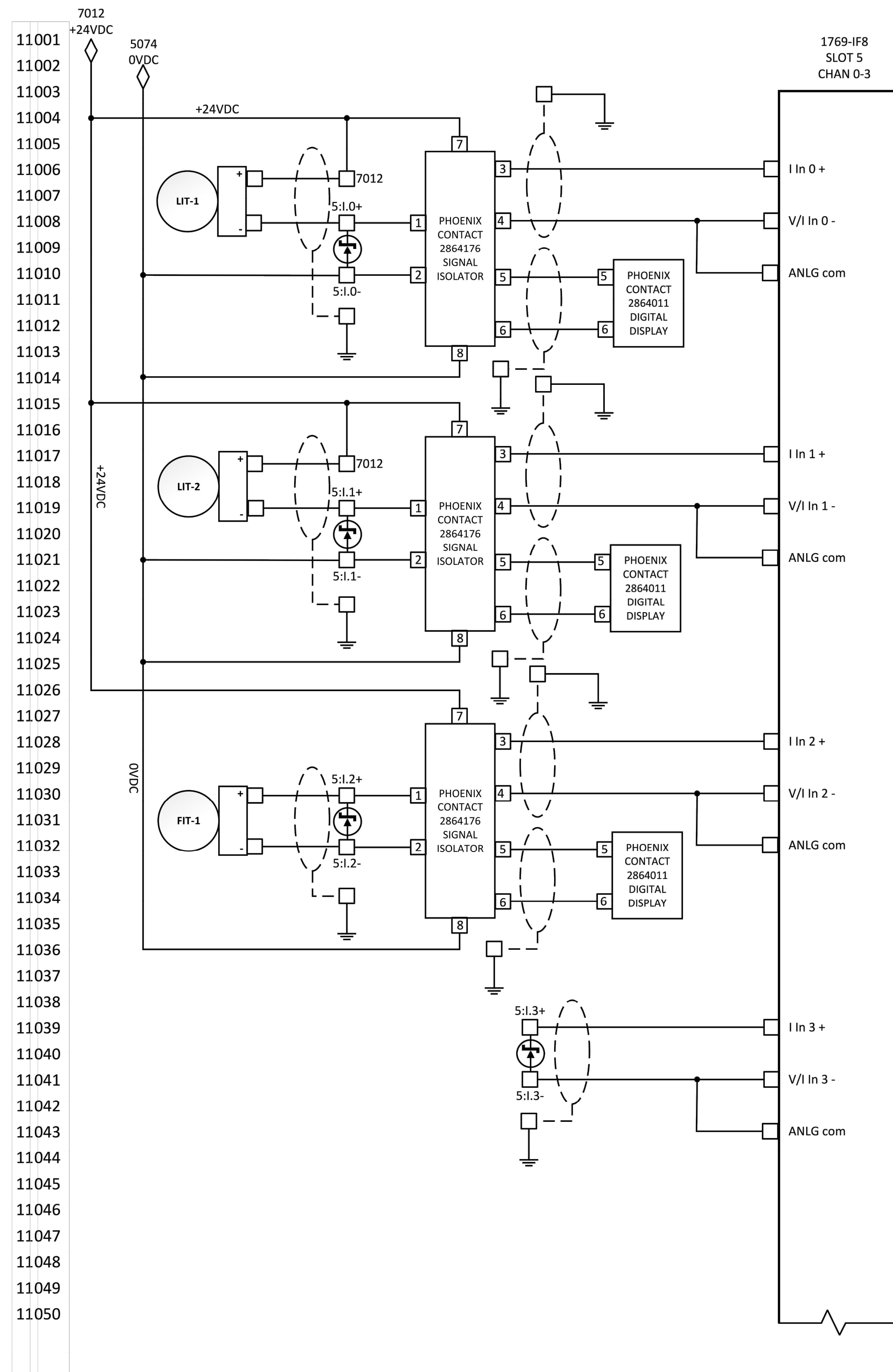

PLOT SCALE: 0.3889:1 EDT: 04/20/2019 1:25 PM EDITED: BPG/ffhb PATH: C:\2018\20180344\1_0_0344\1_0_0344.dwg

REVISIONS		
DATE	REVISION	BY



RECOMMENDED FOR APPROVAL	DESIGN ENGINEER	5/31/2019	DATE
DESIGNED: CC	DRAWN: CC		
CHECKED: CC	CHECKED: CC		

WHITE RIVER WELL #3
VOC REMOVAL
ANALOG INPUTS

CEG PROJECT NUMBER	20WR02557
CONSULTANT PROJECT NUMBER	201800344
SHEET	I-11

PLOT SCALE: 0.38891 EDIT DATE: 5/4/2019 1:26 PM EDITED BY: jgiffith PATH: C:\2018\20180344\1_drawing\environmental\20180344_e\18c.dwg

12001
 12002
 12003
 12004
 12005
 12006
 12007
 12008
 12009
 12010
 12011
 12012
 12013
 12014
 12015
 12016
 12017
 12018
 12019
 12020
 12021
 12022
 12023
 12024
 12025
 12026
 12027
 12028
 12029
 12030
 12031
 12032
 12033
 12034
 12035
 12036
 12037
 12038
 12039
 12040
 12041
 12042
 12043
 12044
 12045
 12046
 12047
 12048
 12049
 12050

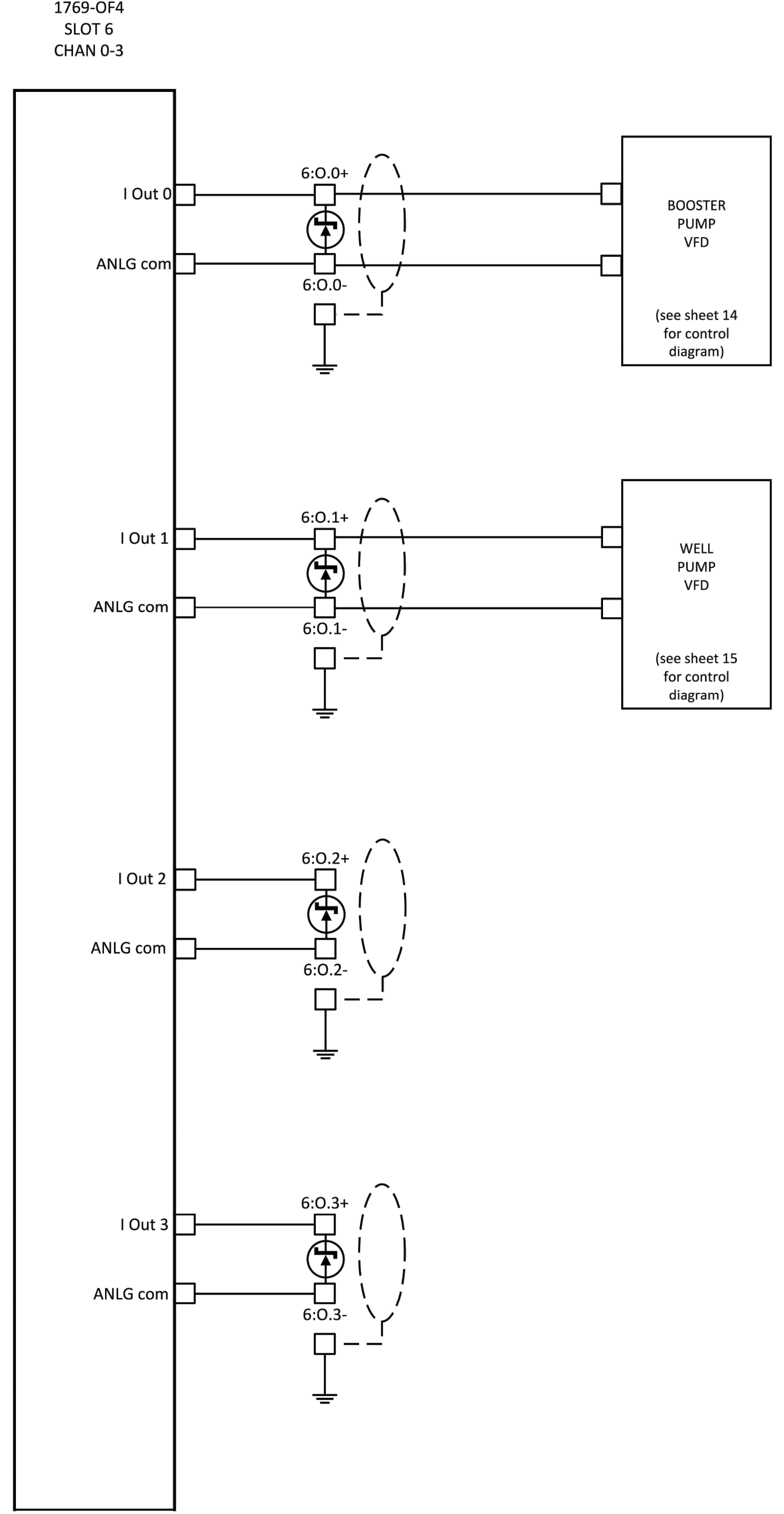

BOOSTER PUMP
SPEED REFERENCE

WELL PUMP SPEED
REFERENCE

SPARE

SPARE

REVISIONS		
DATE	REVISION	BY



RECOMMENDED FOR APPROVAL	DESIGN ENGINEER	DATE
		5/31/2019
DESIGNED: CC	DRAWN: CC	
CHECKED: CC	CHECKED: CC	

WHITE RIVER WELL #3 VOC REMOVAL
ANALOG OUTPUTS

CEG PROJECT NUMBER	20WR02557
CONSULTANT PROJECT NUMBER	201800344
SHEET	I-12

PLOT SCALE: 0.3889:1 EDT DATE: 5/4/2019 1:25 PM EDITED BY: jgiffith PATH: C:\2018\20180344\1.dwg DRAWING: environment\20180344.dwg

- 13001
- 13002
- 13003
- 13004
- 13005
- 13006
- 13007
- 13008
- 13009
- 13010
- 13011
- 13012
- 13013
- 13014
- 13015
- 13016
- 13017
- 13018
- 13019
- 13020
- 13021
- 13022
- 13023
- 13024
- 13025
- 13026
- 13027
- 13028
- 13029
- 13030
- 13031
- 13032
- 13033
- 13034
- 13035
- 13036
- 13037
- 13038
- 13039
- 13040
- 13041
- 13042
- 13043
- 13044
- 13045
- 13046
- 13047
- 13048
- 13049
- 13050

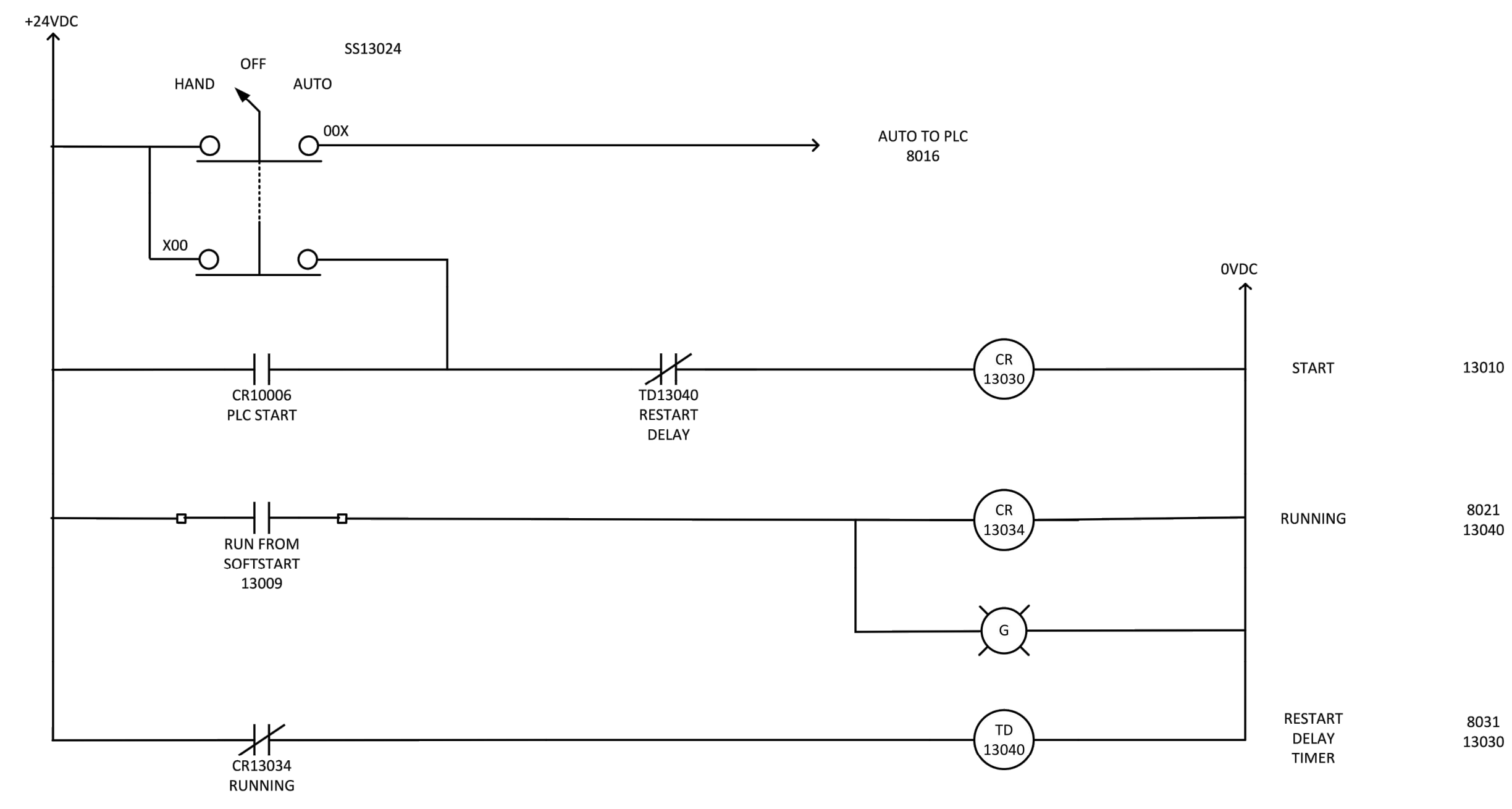
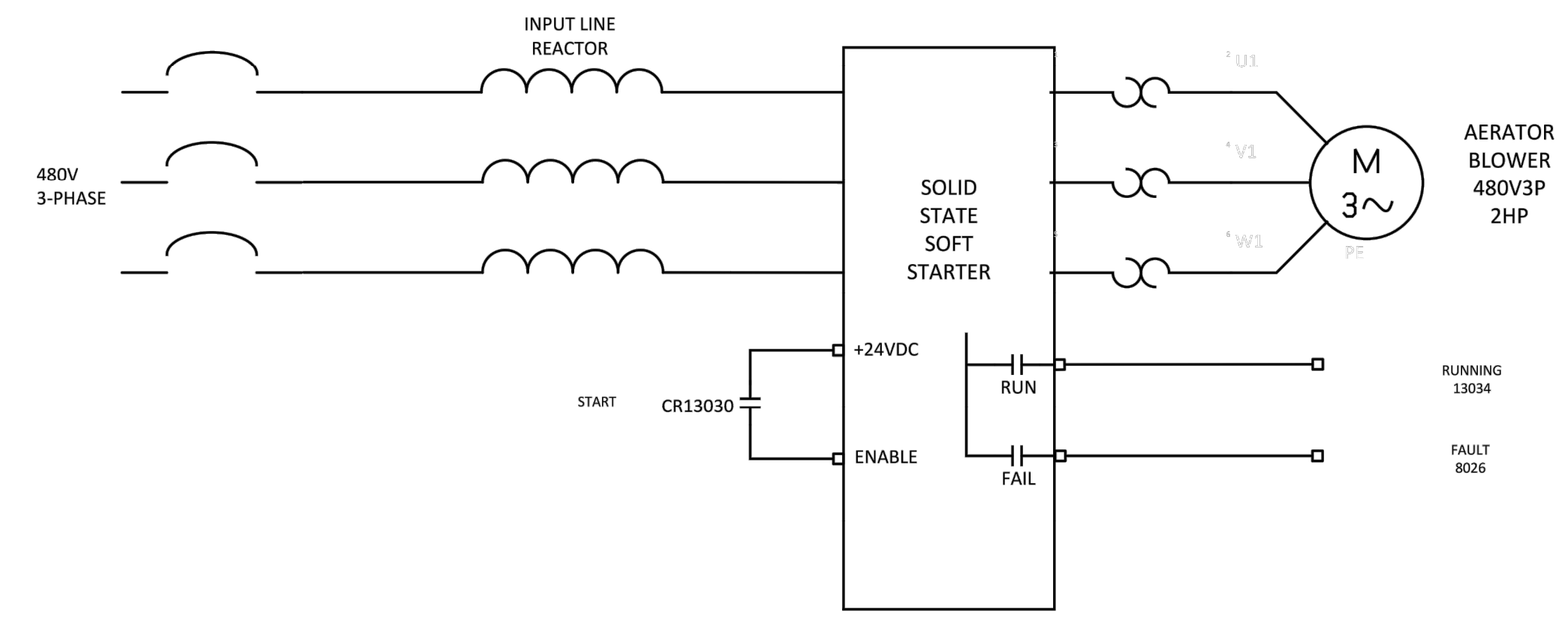

AERATOR BLOWER WIRING DIAGRAM

REVISIONS		
DATE	REVISION	BY



RECOMMENDED FOR APPROVAL	5/31/2019
DESIGN ENGINEER	DATE
DESIGNED: CC	DRAWN: CC
CHECKED: CC	CHECKED: CC

WHITE RIVER WELL #3 VOC REMOVAL
BLOWER CONTROL DIAGRAM

CEG PROJECT NUMBER	20WR02557
CONSULTANT PROJECT NUMBER	201800344
SHEET	I-13

PLOT SCALE: 0.3889:1 EDT DATE: 5/4/2019 1:25 PM EDITED BY: jgiffith PATH: C:\2018\20180334\1.dwg DRAWING: 20180334.dwg

- 14001
- 14002
- 14003
- 14004
- 14005
- 14006
- 14007
- 14008
- 14009
- 14010
- 14011
- 14012
- 14013
- 14014
- 14015
- 14016
- 14017
- 14018
- 14019
- 14020
- 14021
- 14022
- 14023
- 14024
- 14025
- 14026
- 14027
- 14028
- 14029
- 14030
- 14031
- 14032
- 14033
- 14034
- 14035
- 14036
- 14037
- 14038
- 14039
- 14040
- 14041
- 14042
- 14043
- 14044
- 14045
- 14046
- 14047
- 14048
- 14049
- 14050

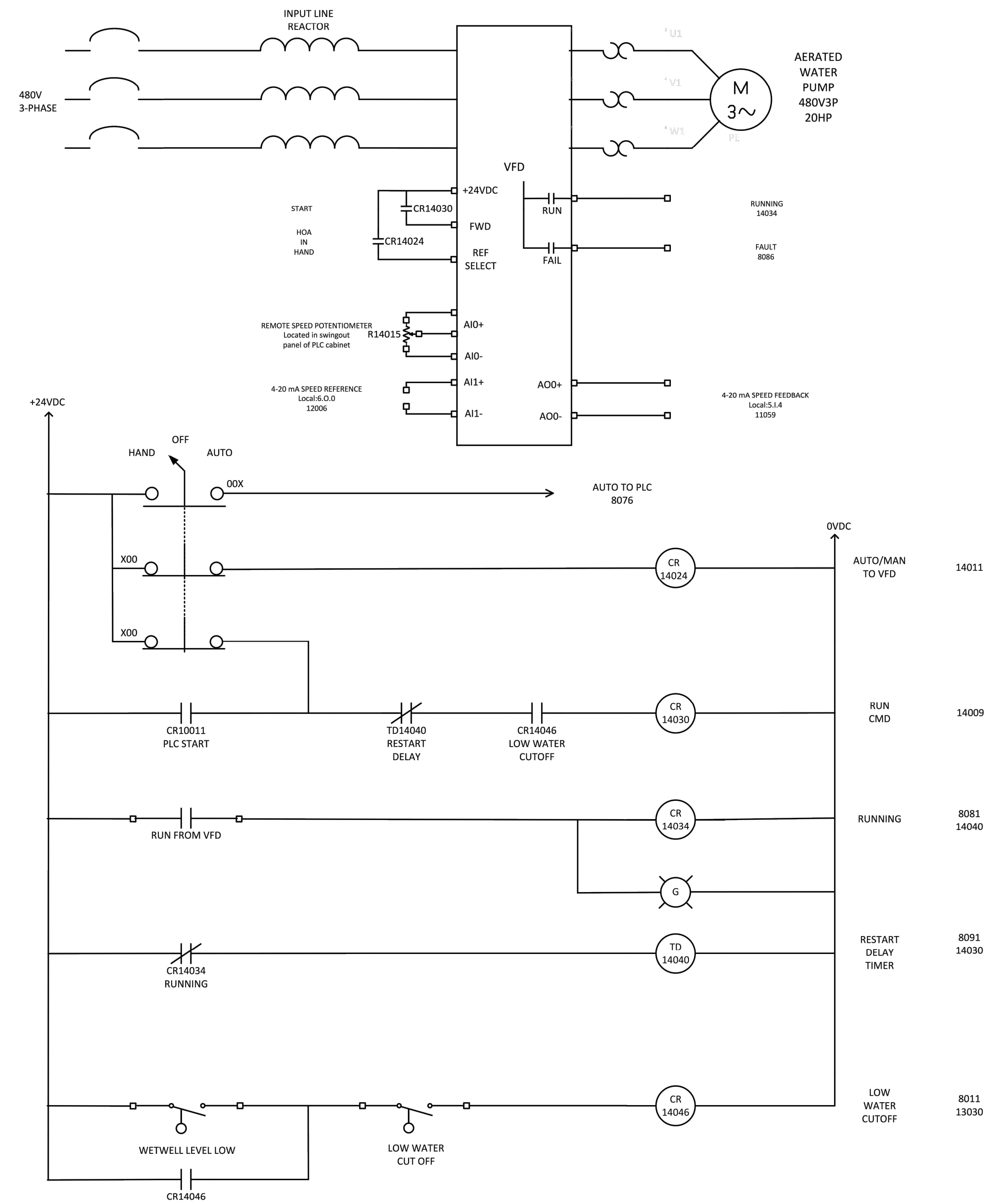

AERATED WATER PUMP WIRING DIAGRAM

REVISIONS		
DATE	REVISION	BY



RECOMMENDED FOR APPROVAL	DESIGN ENGINEER	DATE
		5/31/2019
DESIGNED: CC	DRAWN: CC	
CHECKED: CC	CHECKED: CC	

WHITE RIVER WELL #3 VOC REMOVAL	
BOOSTER PUMP CONTROL DIAGRAM	

CEG PROJECT NUMBER	20WR02557
CONSULTANT PROJECT NUMBER	201800344
SHEET	I-14

PLOT SCALE: 0.3889:1 EDT DATE: 5/4/2019 1:25 PM EDITED BY: jgiffith PATH: C:\2018\20180344\1.dwg DRAWING: 20180344.dwg

- 15001
- 15002
- 15003
- 15004
- 15005
- 15006
- 15007
- 15008
- 15009
- 15010
- 15011
- 15012
- 15013
- 15014
- 15015
- 15016
- 15017
- 15018
- 15019
- 15020
- 15021
- 15022
- 15023
- 15024
- 15025
- 15026
- 15027
- 15028
- 15029
- 15030
- 15031
- 15032
- 15033
- 15034
- 15035
- 15036
- 15037
- 15038
- 15039
- 15040
- 15041
- 15042
- 15043
- 15044
- 15045
- 15046
- 15047
- 15048
- 15049
- 15050

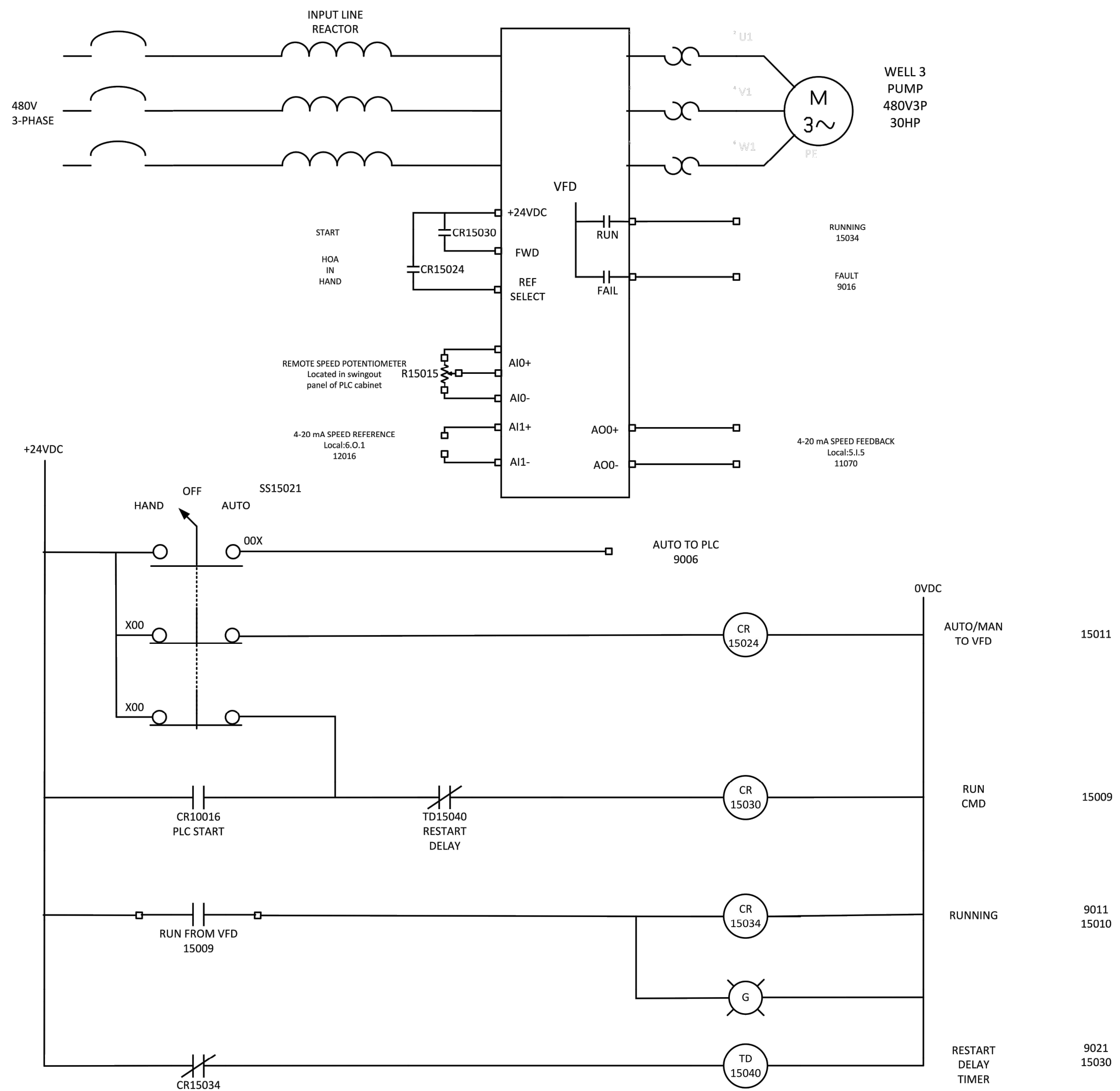

WELL 3 PUMP WIRING DIAGRAM

REVISIONS		
DATE	REVISION	BY



RECOMMENDED FOR APPROVAL	DESIGN ENGINEER	DATE
		5/31/2019
DESIGNED: CC	DRAWN: CC	
CHECKED: CC	CHECKED: CC	

WHITE RIVER WELL #3 VOC REMOVAL
WELL PUMP CONTROL DIAGRAM

CEG PROJECT NUMBER	20WR02557
CONSULTANT PROJECT NUMBER	201800344
SHEET	I-15

Submittal Information Sheet

Job: 1319048. CEG WR VOC Removal
Section: Aerator-01 rev. 0
Vendor: WESTECH
Submittal Title: Aluminum Forced Draft Aerator
Sent Date: 09/06/2019

Bowen Review Comments:

Please see attached submittal information for Aluminum Forced Draft Aerator for your review. This submittal includes the following informational attachments:

11500 Rev.0 - Aerator-01 - 1 PDF

If you have any questions or concerns please contact Bowen's Andrew Drinnon at adrinnon@bowenengineering.com or 317-954-4631.

This submittal is in reference to the CEG White River VOC Removal Project.

Please review and return approved submittals as submitted by 09/27/2019

Contractor's Stamp

Checked and approved by:
Bowen Engineering Corp

By: Andrew Drinnon

Date: 09/06/2019

Project: 1319048.

Spec: 11500

Submittal No: Aerator-01 rev. 0

Supplier is responsible for quantity, size and dimensions.
NOTE: This review is for general conformance with the Contract Documents. It shall not be construed as relieving the supplier or subcontractor of the full responsibility for fulfilling the requirements of the Contract Documents.

Architect's/Engineer's Stamp

AMERICAN
STRUCTUREPOINT
INC.

9025 RIVER ROAD, SUITE 200
INDIANAPOLIS, IN 46240
TEL 317.547.5580

REVIEWED NOT ACCEPTED RECORD COPY
 REVIEWED AS NOTED REVISE AND RESUBMIT

BY: **KMB** DATE: **9/11/2019**

PROJECT NO.: **2018.00344**

This submittal has been reviewed for conformance with the design concept and for compliance with the contract documents only. The notes made do not relieve the CONTRACTOR from compliance with the contract documents. Design and certification of manufactured items that are not specifically designed and detailed in the contract documents are the responsibility of the registered professional engineer working for the CONTRACTOR. The CONTRACTOR is responsible for all dimensions, quantities, fabrication, fit, and the coordination with other trades. Dimensions shall be confirmed and correlated by the CONTRACTOR at the job site. Any changes made to the submittal, other than those indicated by our review, shall be clouded or otherwise highlighted on subsequent submittals.

LETTER OF TRANSMITTAL

*WLT14



600 ARRASMITH TRAIL
AMES, IA 50010 US

Phone: 515-268-8400
Fax: 515-268-8500

Document No.
14604

Requested Ship Date:09/05/19	Group: 62	Job No.: 23925A
Required Del Date:09/05/19	Status:	Job Name: WHITE RIVER WELL 3 VOC REMOVAL
Re:		Project Manager: ALLYSON A DENNIS

from: WESTECH ENGINEERING, INC. 600 ARRASMITH TRAIL AMES, IA 50010	to: Kevin Canida White River Well 3 1999 Aqueduct Street Indianapolis, IN 46202 US
Ph/Fax: 515-268-8400 / 515-268-8500 Email/Cell: WESTECH-INC\ADENNIS@Westech-Inc.com /	Ph/Fax: 317.842.2616 / Email/Cell: /

We are sending you: Attached Under Separate Cover **Via:** Best Way Other EMAIL

the following items:

<input type="checkbox"/> Shop Drawings	<input checked="" type="checkbox"/> Submittal Drawings	<input type="checkbox"/> O&M Manuals	<input type="checkbox"/> Specifications
<input type="checkbox"/> Copy of Letter	<input type="checkbox"/> Change Order	<input type="checkbox"/> Other	

Copies	Number	Rev	Description
--------	--------	-----	-------------

These are transmitted as checked below:

- | | | |
|--|--|---|
| <input checked="" type="checkbox"/> For Approval | <input type="checkbox"/> Approved as Submitted | <input type="checkbox"/> For Bids Due |
| <input type="checkbox"/> For Your Use | <input type="checkbox"/> Approved as Noted | <input type="checkbox"/> Prints Returned After Loan to WEI |
| <input type="checkbox"/> As Requested | <input type="checkbox"/> Returned for Corrections | <input type="checkbox"/> Returned <input checked="" type="checkbox"/> Approved Prints |
| <input type="checkbox"/> For Review and Comment | <input type="checkbox"/> Returned <input checked="" type="checkbox"/> Corrected Prints | <input type="checkbox"/> Other |
- Please Return Submittal By _____ to Avoid Delaying Project.

Remarks:

X *Ally D*
Signed

Submittal

Date: August 23, 2019

Revision: -

For:

White River Well 3 VOC Removal
Indianapolis, Indiana

Equipment:

One (1) Aluminum Forced Draft Aerator
96 Inches Square x 120 Inches Straight Side Height
Specification Section: 11500 – Aluminum Forced Draft Aerator
WesTech Model AWF310

WesTech Contact:

Project Manager: Ally Dennis
Phone: (515) 268.8467
Email: adennis@westech-inc.com

WesTech Job Number: 23925A

WESTECH

Copyright 2019

The contents of this manual are the confidential property of WesTech Engineering Inc. Circulation, distribution, or reproduction of this manual in whole or in part without written permission is prohibited by law. Possession of this manual neither confers nor transfers any rights, which may be detrimental to WesTech's interest.



For:

White River Well 3 VOC Removal
Indianapolis, Indiana

Equipment:

One (1) Aluminum Forced Draft Aerator
96 Inches Square x 120 Inches Straight Side Height
WesTech Model AWF310

Engineer:

American Structurepoint Inc.
7260 Shadeland Station
Indianapolis, Indiana 46256-3957
Contact: Michael David Mohler II, P.E.
Phone: (317) 547.5580
Email: -

Contractor:

Bowen Engineering Corporation
8802 North Meridian Street
Indianapolis, Indiana 46260
Contact: Kevin Canida, Project Manager
Phone: (317) 842.2616
Email: kcanida@bowenengineering.com

WesTech Agent:

B.L. Anderson, Inc.
4801 Tazer Drive / P.O. Box 2237
Lafayette, Indiana 47905
Contact: Rick Kocerha
Phone: (765) 463.1518
Email: rick@blanderson.com

Manufacturer:

WesTech Engineering, Inc.
600 Arrasmith Trail
Ames, Iowa 50010
Phone: (515) 268.8400
Fax: (515) 268.8500
24 Hour Emergency Assistance: (801) 265.1000

WesTech Contact:

Project Manager: Ally Dennis
Phone: (515) 268.8467
Email: adennis@westech-inc.com

WesTech Job Number: 23925A

This Page Intentionally Blank

Cover Page
 Title Page
 Table of Contents
 Product Line Cards

Section One: Submittal Introduction 1-0
 Submittal Introduction..... 1-1

Section Two: Manufacturer Information 2-0
 Manufacturer Information..... 2-1
 ISO Certification 2-3
 ISO 9001:2015 Certification..... 2-5

Section Three: Equipment Information..... 3-0
 Warranty 3-1
 One Year Warranty 3-3
 Scope of Supply..... 3-5
 Clarifications and Specification Deviations 3-11
 Clarifications..... 3-13
 Specification Deviations..... 3-14
 Specification Review 3-16

Section Four: Mechanical Drawings..... 4-0
 Mechanical Drawings..... 4-1

Section Five: Mechanical Component Data Sheets..... 5-0
 Mechanical Component Data Sheets..... 5-1

Drawing Number	Description
1-47949	Mechanical Aeration
23925A-DS01	Forced Draft Blower Scope of Supply
23925A-DS02	Aerator Media Scope of Supply

This Page Intentionally Blank

WesTech Corporate Services

Parts / Field Service / Training

- 24 Hour Hot-Line
- Full Service Parts Department
- Installation and Erection Services
- Mechanical Evaluations / Process Audits
- Operator Training
- Process Training
- Regional Service Technicians
- Service and Maintenance Agreements

Laboratory and Pilot Plant Testing

- Bench Scale Feasibility Testing
- Field Pilot Testing / Studies
- Plant Process Audits

Services

- Bench Scale Feasibility Testing
- Field Pilot Studies
- Installation and Erection Services
- Mechanical Evaluations
- Plant Process Audits

Pilot Rental Equipment

- AERALATER® - Aeration, Detention, and Filtration
- AltaFlo™ High Rate Thickener
- Buoyant Media Clarifier
- CONTRAFAST®- C
- CONTRAFAST®- E
- CONTRAFLO®
- Denitrification Filtration
- Dissolved Air Flotation
- Dual-Column Filtration
- Forced Draft Aerator
- High Rate Thickener
- Horizontal Belt Filter
- Inclined Plate Settler
- Linear Screen
- Microfiltration/Ultrafiltration
- Nanofiltration/Reverse Osmosis
- Paste Thickener
- Precoat Filter
- Pressure and Gravity Filter
- RapiSand™ Ballasted Flocculation solids CONTACT CLARIFIER™
- SuperSand™
- SuperDisc™
- Vacuum Drum Filter
- Trident®, Trident® HS

WesTech Municipal Water Products

Aeration

ATOMERATOR™
Cascade Aerator
Forced Draft Aerator
Induced Draft Aerator

Adsorption

Adsorption Clarifier®
Cation Exchange Softener
Granular Activated Carbon (GAC) Contactor

Covers

Zickert Retractable Membrane Cover

Electrical Controls

PLC Based Control System
UL Listed Panels (UL508A/UL698)

Flocculation

Horizontal Paddle Wheel Flocculator
Vertical Paddle Wheel Flocculator

Granular Media Filtration

ANTHRA/SAND™ Manganese Removal Media
CENTROL® LP Cluster Filter
Circular and Rectangular Open Top Gravity Filter
ESSD™ Filter Trough
MULTIWASH® Filtration Process
MULTIBLOCK® Underdrain
MULTICRETE™ II Underdrain
Multi-Tech™ Multiple Barrier Filtration System
Horizontal Pressure Filter
Vertical Pressure Filter

Membrane Filtration

Microfiltration/ Ultrafiltration
Nanofiltration/Reverse Osmosis
VersaFilter™

Residuals Handling

Backwash Water Clarifier
Decanter Mechanism
Gravity Sludge Thickener
SuperSettler™ Inclined Plate Settler
Vacuum Drum Filter

Package Treatment Plants

AERALATER® Iron and Manganese Removal Plant
AltaPac™ Ultrafiltration Membrane System
Aquarius™ Conventional Package Plant
Tri-Mite™ Package Plant
Trident® Package Water Treatment System
Trident® HS Multi Barrier Package Plant
Water Boy™ Package Plant

Sedimentation/Clarification

Adsorption Clarifier®
Conventional Clarifier
CONTRAFLO® Solids Contact Clarifier
CONTRAFAST® High Rate Clarifier/Thickener
Flocculating Clarifier
RapiSand™ Ballasted Flocculation
Sludge Sucker™ Sludge Siphon Clarifier
solids CONTACT CLARIFIER™
SPIRACONE™ Clarifier
SuperSettler™ Inclined Plate Settler
Trident® HSC Multi-Barrier Clarifier
Zickert Shark™ Sludge Removal

Softening

Cation Exchange Softener
CONTRAFLO® Solids Contact Clarifier
CONTRAFAST® High Rate Clarifier/Thickener
solids CONTACT CLARIFIER™

Tankage

Anchor Channel Tank
Flat Bottom Tank
Elevated Tank

WESTECH

Phone: 801.265.1000
www.westech-inc.com

WesTech Municipal Wastewater Products

Anaerobic Digestion Equipment

- Cleanergy Biogas Generator
- Digester Cover - Radial Beam Style
- Digester Cover - Truss Style
- DuoSphere™ Dual-Membrane Gas Holder
Slab and Tank Mount
- Extreme Duty™ Mechanical Sludge Mixer
- Sludge Heating System

Biological Treatment

- BioDoc™ Rotary Distributor
- ClearLogic™ MBR System
- HydroDoc™ Rotary Distributor
- Landex™ Oxidation Ditch
- OxyStream™ Advanced Oxidation Ditch
Process
- Package Plants
- RSD1™ Rotary Distributor
- Slow Speed Surface Aerators
- STM-Aerotor™ IFAS Systems

Clarifiers

- C.O.P™ Clarifier Optimization Package
 - Spiral Blades
 - Sludge Ring
 - Dual Gate EDI
- Conventional Scraper Blade
- RapiSand™ Ballasted Flocculation
solids CONTACT CLARIFIER™
- Suction Header
- Suction Pipe
- Zickert Shark™

Combined Sewer Overflow

- ROMAG CSO Screens
- WWETCO FlexFilter™
- WWETCO FlexFlo™ Control Valve

Dissolved Air Flotation

- Algae Removal
- Pretreatment Clarifiers
- Rectangular & Circular
- Sludge Thickeners

Electrical Controls

- PLC Based Control Systems
- UL Listed Panels (UL508A/UL698)

Filters

- CenTROL® LP Cluster Filter
- MULTIWASH® Filtration Process
- SuperSand™ Continuous Backwash Filter
- SuperDisc™ Cloth Media Disc Filter
- Trident® Package Plant
- WWETCO FlexFilter™

Headworks

- CleanFlo™ Rotoscreen® Fine Screen
- CleanFlo™ Monoscreen® Fine Screen
- CleanFlo™ ALL-IN-ONE (Complete Plant)
- CleanFlo™ Element Continuous Belt Screen
- CleanFlo™ MultiRake
- CleanFlo™ Shear (Internally Fed Rotary Drum
Screen)
- CleanFlo™ Spiral Screen (Inclined and Vertical)
- CleanWash™ Screw Wash and Counter Pressure
Screw
- CleanGrit™ Grit Washers
- Gritt Mitt™ Grit Classifiers
- Shaftles Spiral Conveyor and Compactor
- Vortex Grit Separators
- Zickert Shark™ Grit and Grease Removal

Membrane Filtration

- Microfiltration/Ultrafiltration
- Nanofiltration/Reverse Osmosis
- VersaFilter™

Rectangular Basin Skimming

- Helical Scum Skimmers
- Rotating Scum Pipes
- Zickert Skimmer

Replacement Drives

- Adaptable to All Other Manufacturers
- Clarifiers
- Grease Lubricated Option
- Precision Bearing
- Thickeners

Septage Receiving Station

- Customer Management / Billing Software
- Hauler Access Stations
- Screening and Grit Removal Options

Tankage

- Field Erection
- Material Supply

Thickeners

- Center Feed
- CleanFlo™ Rotary Drum Thickener
- DAF Thickening
- Rake Lifting Devices
- Side Feed

WesTech Industrial Water and Wastewater Products

Aeration

Cascade Aerator
Forced / Induced Draft Aerator

Barrier / Media Filtration

AERALATER® Iron / Manganese Removal
AltaPac™ Ultrafiltration Package Systems
Cation Exchange Softeners
Circular or Rectangular Gravity Filter
CentROL® LP Cluster Filter
GAC Contactors
Microfiltration/ Ultrafiltration
Multi-Tech™ Multiple Barrier Filtration System
MULTIWASH® Filtration Process
Nanofiltration/ Reverse Osmosis
Pressure Filter (Vertical or Horizontal)
Self Stored Backwash Filter
SuperDisc™ Cloth Media Disc Filter
SuperSand™ Continuous Backwash Filter
Tri-Mite™ and Trident® Package Treatment
Trident® HS Package Plant
VersaFilter™ Membrane Filtration
Water Boy™ and Aquarius™ Package Plant
WWETCO FlexFilter™

Biological Treatment

BioDoc®/ HydroDoc Rotary Distributor
Biotreater
Cleanergy Biogas Generator
ClearLogic MBR Systems
DuoSphere™ Dual Membrane Gasholder
Slab or Tank Mount
HydroDoc™ Rotary Distributor
Oxidation Ditches
Slow Speed Surface Aerators
STM Aerotor™ IFAS Systems
UASB – Upflow Anaerobic Sludge Blanket

Clarification / Sedimentation

Backwash Clarifier
Buoyant Media Clarifier
Conventional Clarifier
Cooling Tower Slip Stream Treatment
COP™ Clarifier
Draft Tube™ Clarifier
CONTRAFast® High Rate Clarifier/Thickener
Flocculating Clarifier
Metallurgical Contact Clarifier

Rapisand™ Ballasted Flocculation
Rim Drive Clarifiers
Scale Pit Scraper/Skimmer
Sludge Sucker
SPIRACONE™ Clarifier
solids CONTACT CLARIFIER™
Suction Header COP
Suction Pipe Clarifiers
SuperSettler™ Inclined Plate Settler
Traveling Bridge Clarifiers
Zickert Shark™ Sludge Removal

Clarifier / Thickener Drives

Bridge Supported Shaft Drive
Column Supported Cage Drive
PasteThick™ Drive
Replacement, Retrofit, and Rebuild Options
for All Manufacturers
Titan Traction™ Drive

Dewatering

Belt Press
Ceramic Disc Filter
Horizontal Vacuum Belt Filter
Precoat Drum Filter
Recessed Plate Filter Press
Rotary Vacuum Disc Filter
Rotary Drum Vacuum Filter
Tower Press

Dissolved Gas Flotation

Circular
Rectangular

Electrical Controls

PLC Based Control Systems
UL Listed Panels (UL508A / UL698)

Oil / Water Separation

DAF Units (Circular or Rectangular)
DNF Units (Circular or Rectangular)
Oil / Water Separator (Circular or Rectangular)
Scale Pit Skimmer/Scraper

Screens

CleanFlo™ Rotoscreen®
CleanFlo™ Monoscreen®
CleanFlo™ ALL-IN-ONE (Complete Plant)
CleanFlo™ Element Continuous Belt Screen

WESTECH

Phone: 801.265.1000
www.westech-inc.com

CleanFlo™ Shear (Internally Fed Drum Screen)
CleanFlo™ Spiral Screen (Inclined and Vertical)
CleanWash™ Screenings Washer / Compactor
Counter Pressure Screw
CleanGrit™ Grit Washers
Gritt Mitt™ Grit Classifiers
Vortex Grit Separators
Zickert Shark™ Grit and Grease Removal

Softening

Cation Exchange Softener
Cold Lime Softener
Warm Lime Softener

Tankage

Anchor Channel Tank
Elevated Tank
Steel Bottom Tank
Supply and / or Field Erection

Thickeners

AltaFlo™ High Rate Thickener
Conventional Thickener
Deep Bed™ Paste Thickener
HiDensity™ Paste Thickener
HiFlo™ High Rate Thickener
Swing Lift Thickener
Traction Drive Thickener
TOP™ Thickener Package

WesTech Industrial Mining and Metallurgical Products

Clarifiers

- Buoyant Media Clarifier
- Flocculating Clarifier
- Metallurgical Contact Clarifier
- RapiSand™ Ballasted Flocculation
- Solids CONTACT CLARIFIER™
- CONTRAFAST® High Rate Clarifier/Thickener
- SuperSettler™ Inclined Plate Settler

Heavy Duty Drives

- Bridge Supported Shaft Drive
- Column Supported Cage Drive
- PasteThick™ Drive
- Retrofit and Rebuild Options for All Manufacturers
- Titan Traction™ Drive

Granular Media Filtration

- CentROL® LP Cluster Filter
- Circular & Rectangular Gravity Filter
- MULTICELL® Horizontal Pressure Filter
- Multi-Tech™ Multiple Barrier Filtration System
- MULTIWASH® Filtration Process
- Self-Stored Backwash Filter
- SuperSand™ Continuous Backwash Filter
- Vertical Pressure Filter
- WWETCO FlexFilter™

Man Camp Potable Water Treatment

- AltaPac™ Ultrafiltration Package System
- Tri-Mite™ & Trident® Package Plant
- Water Boy™ & Aquarius™ Package Plant

Man Camp Wastewater Treatment

- BioTreater
- ClearLogic™ MBR System
- STM-Aerotator™ IFAS Package System

Membrane Filtration

- AltaPac™ Ultrafiltration Package System
- Microfiltration/ Ultrafiltration
- Nanofiltration/ Reverse Osmosis
- VersaFilter™

Screens

- CIP / CIL, RIP/RIC Media Retention Screen
- Linear Trash Screen
- Screw Classifiers

Tankage

- Anchor Channel Tank
- Elevated Tank
- Steel Bottom Tank
- Supply and / or Field Erection

Thickeners

- AltaFlo™ High Rate Thickener
- Conventional Thickener
- Deep Bed™ Paste Thickener
- HiDensity™ Paste Thickener
- HiFlo™ High Rate Thickener
- Swing Lift Thickener
- TOP™ Thickener Package

Dewatering

- Disc Filter
- Horizontal Belt Filter
- Precoat Drum Filter
- Rotary Drum Filter
- Belt Discharge
- Roll Discharge
- Scraper Discharge
- Tower Press

This Page Intentionally Blank

Section One: Submittal Introduction

This Page Intentionally Blank

Submittal Introduction

This submittal is being furnished for the approval of the equipment listed and is pursuant of WesTech Engineering, Inc. standard design and Proposal Number 1630256 with exceptions and clarifications noted in Section “Specification Deviations and Clarifications” and on submittal drawings.

A complete outline of equipment and materials supplied is listed in the enclosed Scope of Supply. If items have been changed from original accepted scope, the items are lined through and modifications are noted. The attached documents, including all drawings and/or Data Sheets, are enclosed as a detailed description of materials to be supplied.

All other materials not specifically included on the drawings or in the body of this submittal are not part of WesTech’s scope of supply and are to be supplied by others.

Installation, Operation, and Maintenance Manuals shall follow in a timely manner and will be supplied per WesTech standard format.

A copy of all customer reviewed and approved General Arrangement Drawings (Shop Drawings) and Equipment Erection/Assembly Drawings will be included in the Installation, Operation and Maintenance Manuals.

When dimensions on plans or on drawings are questioned, the drawings may have clouded dimensions. If dimensions have been clouded, approval to proceed with production will not be recognized by WesTech until the dimensions in question are confirmed or supplied.

Re-submittals: The enclosed information will not be duplicated in any future re-submittals, unless:

- Items/sections have been commented on and need clarification or revision.

- Specifically requested by the Engineer or Contractor on the return Letter of Transmittal that the entire submittal must be duplicated.

This Page Intentionally Blank

Section Two: Manufacturer Information

This Page Intentionally Blank

Manufacturer Information

Who is WesTech?

WesTech engineers and manufactures process equipment and working solutions for water, wastewater and industrial applications. Drawing upon nearly half a century of experience, we provide our customers around the world with the best value and solutions for their process needs. The water technologies we advance and apply benefit not only our customers, but also society as a whole.

Quality Policy

We, the
Employee owners of WesTech are dedicated to:
Continuous Improvement,
Alignment with our core values,
Responsive service, and
Exceeding our customer's expectations

WESTECH[®]

This Page Intentionally Blank

ISO Certification

This Page Intentionally Blank

ISO 9001:2015 Certification

Certificate US95/0255.00

The most responsive supplier of products and services for liquid-solid separation and the treatment of water and wastewater.

WesTech Engineering, Inc. is certified to the ISO 9001:2015 standard with SGS Systems & Services Certification. SGS is an independent ISO registrar, who conducts regular audits of clients' management processes.

ISO 9001:2015 ensures the consistency of quality practices and requires continuous improvement of WesTech's entire management system. Certification therefore assures customers that:

1. WesTech's products and services will consistently meet or exceed an internationally agreed-upon level of quality, and
2. Proactive management practices will enable it to anticipate and address customers' future needs, while paying careful attention to existing installations.

Founded in 1973, WesTech has attained preferred-supplier status with an overwhelming majority of its worldwide customers. As a leading innovator in the development of equipment that lowers overall costs by improving efficiency, reliability, and performance, the firm has been approved by virtually all major consultants for their projects.

WesTech is an employee-owned company. Since the Employee Stock Ownership Plan holds a majority of the stock, design and support personnel are naturally committed to the success of their projects and customers. Attitudes, behaviors, and decisions are further shaped by WesTech's six core values, which are:

- Exhibit honesty and integrity
- Take pride in doing the right things, and in doing them well
- Value our people and their families
- Make and keep commitments
- Achieve productivity through hard work and intelligence
- Provide superior service

The net result of WesTech's continuing ISO certification, combined with its distinctive ownership culture, is that customers can expect to be taken care of by exceptionally responsive associates who consistently deliver superior solutions. The company's stunning multi-year Customer Satisfaction rating of 95% is evidence of the power and effectiveness of this combination.

We invite you to learn more about our company, capabilities, and products - and then continually put us to the test. Find out for yourself why we say, "We not only guarantee our equipment, we guarantee peace of mind!"

This Page Intentionally Blank

SGS

Certificate US95/0255.00

The management system of

WesTech Engineering, Inc.

3665 South West Temple
Salt Lake City, UT 84115, United States

has been assessed and certified as meeting the requirements of

ISO 9001:2015

For the following activities:

The Design, Supply, Sales, and Service of Water and Waste Water Treatment and Liquid-Solid Separation Equipment.

Further clarifications regarding the scope of this certificate and the applicability of
ISO 9001:2015 requirements may be obtained by consulting the organization.

This certificate is valid from 20 October 2017 until 20 October 2020
and remains valid subject to satisfactory surveillance audits.
Recertification audit due a minimum of 60 days before the expiration date.
Issue 11: 20 October 2017. Certified since June 1995.

The audit leading to this certificate commenced on 06/07/2017.
Previous issue certificate validity date was until 20/10/2017.

This is a multi-site certification.
Additional site details are listed on subsequent pages.

Authorized by:

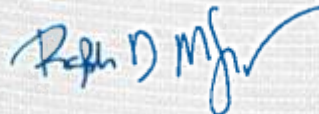

Ralph McLouth
Vice President of Accreditation, North America
SGS North America, Inc.
201 Route 17 North, Rutherford, NJ 07070, USA
t (201) 508-3000 f (201) 935-4555 www.us.sgs.com

This certificate remains the property of SGS and shall be returned upon request

Page 1 of 2



This document is issued by the Company subject to its General Conditions of Certification Services accessible at www.sgs.com/terms_and_conditions.htm. Attention is drawn to the limitations of liability, indemnification and jurisdictional issues established therein. The authenticity of this document may be verified at <http://www.sgs.com/en/certified-clients-and-products/certified-client-directory>. Any unauthorized alteration, forgery or falsification of the content or appearance of this document is unlawful and offenders may be prosecuted to the fullest extent of the law.



WesTech Engineering, Inc.

ISO 9001:2015

Issue 11: 20 October 2017



Detailed Scope (applicable to all sites)
The Design, Supply, Sales, and Service of Water and Waste Water Treatment and Liquid-Solid Separation Equipment.

Additional facilities:

1486 Saint Paul Ave, Gurnee, IL 60031, United States

600 Arrasmith Trail, Ames, IA 50010, United States

3625 South West Temple, Salt Lake City, UT 84115, United States



Section Three: Equipment Information

This Page Intentionally Blank

Warranty

This Page Intentionally Blank

One Year Warranty

WesTech equipment is backed by WesTech's reputation as a quality manufacturer, and by many years of experience in the design of reliable equipment.

Equipment manufactured or sold by WesTech Engineering, Inc., once paid for in full, is backed by the following warranty:

For the benefit of the original user, WesTech warrants all new equipment manufactured by WesTech Engineering, Inc. to be free from defects in material and workmanship, and will replace or repair, F.O.B. its factories or other location designated by it, any part or parts returned to it which WesTech's examination shall show to have failed under normal use and service by the original user within one (1) year following initial start-up, or eighteen (18) months from shipment to the purchaser, whichever occurs first.

Such repair or replacement shall be free of charge for all items except for those items such as resin, filter media and the like that are consumable and normally replaced during maintenance, with respect to which, repair or replacement shall be subject to a pro-rata charge based upon WesTech's estimate of the percentage of normal service life realized from the part. WesTech's obligation under this warranty is conditioned upon its receiving prompt notice of claimed defects, which shall in no event be later than thirty (30) days following expiration of the warranty period, and is limited to repair or replacement as aforesaid.

This warranty is expressly made by WesTech and accepted by purchaser in lieu of all other warranties, including warranties of merchantability and fitness for particular purpose, whether written, oral, express, implied, or statutory. WesTech neither assumes nor authorizes any other person to assume for it any other liability with respect to its equipment. WesTech shall not be liable for normal wear and tear, corrosion, or any contingent, incidental, or consequential damage or expense due to partial or complete inoperability of its equipment for any reason whatsoever.

This warranty shall not apply to equipment or parts thereof which have been altered or repaired outside of a WesTech factory, or damaged by improper installation, application, or maintenance, or subjected to misuse, abuse, neglect, accident, or incomplete adherence to all manufacturer's requirements, including, but not limited to, Operations & Maintenance Manual guidelines & procedures.

This warranty applies only to equipment made or sold by WesTech Engineering, Inc.

WesTech Engineering, Inc. makes no warranty with respect to parts, accessories, or components purchased by the customer from others. The warranties which apply to such items are those offered by their respective manufacturers.

This Page Intentionally Blank

Scope of Supply

This Page Intentionally Blank

Section: 11500 – Aluminum Forced Draft Aerator
 Addenda: None

Item A – One (1) Aluminum Forced Draft Aerator, Model AWF310

Design Criteria	
Application	Oxidize iron and dissolved gas reduction
Design Flow	1,300 gpm
Peak Flow	1,600 gpm
Number of Units	1
Unit Size	96 in square x 120 in shell height
Loading Rate	20.3 gpm/ft ²
Blower Capacity	4,800 cfm @ 3/8 in SP
Air to Water Ratio	3.7:1 (cfm:gpm)

Features and Benefits

A counter-current flow of air, supplied by a forced draft type blower, continuously sweeps through the aerator oxidizing the ferrous iron and carrying away released gases that may be present. Dissolved solids such as iron are transformed to their oxidized states, enabling them to be removed by downstream equipment. In addition, unwanted dissolved gases (e.g., carbon dioxide, hydrogen sulfide, VOCs, radon, etc.) are removed to reduce chemical requirements, stabilize pH, or eliminate objectionable tastes and odors.

- Aluminum construction eliminates painting, and corrosion-resistant internals simplify maintenance.
- Multiple internal media configurations optimize treatment performance.
- Factory assembly minimizes installation costs and prevents field errors.
- Gravity inlet tray ensures uniform water distribution and air collection across internals, and eliminates troublesome spray distribution nozzles. It also minimizes inlet pressure requirements and reduces long-term pumping costs compared to spray aerators.
- General Filter target nozzles equipped with a bell mouthed entrance to minimize clogging and provide even water droplet distribution in the aeration section are located in the distribution tray
- Forced draft blower motor is outside the exhaust air stream, eliminating the potential ignition of combustible gases exhausting the aerator.

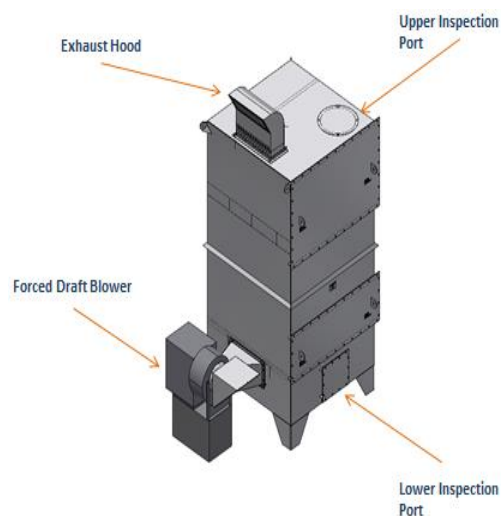

Figure 1: Aluminum Forced Draft Aerator

Aluminum Forced Draft Aerator Shell Scope of Supply

Quantity	Dimension	Notes
1	96 in square x 120 in shell height	Materials of construction are Type 3000 series aluminum plates with Type 6061 aluminum structural members. Shipped complete with the following accessories.
Feature	Notes	
Shell sides and bottom plate	1/4 in thick	
Shell top plate	3/16 in thick	
Lifting lugs	Included	
Nameplate assembly	Included	
Support legs	Includes predrilled anchor holes (Anchor bolts are not by WesTech)	
Air intake flange	Mounting flange for transition section from blower	
Media access	Two bolt-on media access ports on side	
Water distributor	Distribution tray complete with velocity breaker box and air stacks	
Target nozzles	Included	
Media support	Aluminum grating	
Lower inspection port	13 in x 15 in placed below the internals	
Upper inspection port	18 in diameter placed in the cover	
Inlet connection	12 in flanged top side	
Outlet connection	14 in plain end bottom	
Air exhaust connection	Mounting flange in cover for exhaust hood	
Air seal	Located at the internal outlet connection	

Forced Draft Blower Scope of Supply

Quantity	Volume	Pressure	Model	Motor
1	4,800 scfm	3/8 in SP	B182	2 hp, 480 V, 60 Hz, 3 ph, TEFC
Feature	Notes			
Housing	Reinforced heavy steel blower housing with weatherproof motor hood (Anchor bolts are not by WesTech.)			
Blower Wheel	Dynamically balanced welded steel			
Bearings	Anti-friction, self-aligning, grease packed, pillow block type with grease and dirt seal			
Drive	Adjustable V-belt			
Paint	Manufacturer's standard factory primed			

Note: Blower motor starters are not part of WesTech Aeration Equipment supply.

Aerator Media Scope of Supply

Type	Quantity	Layer Depth	Packaging
Polypropylene*	320 ft ³	60 in	10-ft ³ boxes

*Loose Fill media is field installed by others.

Fabrications Scope of Supply

Feature	Quantity	Notes
Air inlet hood	1	Aluminum construction, with hood mounting bolts and screened air intake screen
Discharge transition	1	Aluminum construction, with mounting screws
Air exhaust hood	1	Aluminum construction, with built-in moisture separator, hood mounting screws and aluminum and stainless steel air exhaust screen

Tank Coating

Aerator bottom of support legs	Tank support legs will be shipped bare metal on bottom. It is recommended that the installing contractor provide an appropriate coating or product barrier for aluminum surfaces in contact with the concrete floor.
--------------------------------	--

Notes

- Due to the aluminum alloy used, exposed surfaces may have a dull or uneven appearance, and water staining is possible.
- It is recommended that a delay timer be used to keep the blower running for at least 10 minutes after the pump stops. This is to dry the unit out to prevent icing of the outlet screens in colder climates.
- It is also recommended that a soft start motor starter be provided in the Motor Control Center (MCC) for the forced draft blower motors with V-belt drives. This is to reduce the load on the drive system when starting up the drive. Aerator controls and timers are not by WesTech.
- Aerator influent flanged connection is not designed to support the weight of the influent piping. Alternate means of influent pipe support should be provided.

Weights

Estimated Total Shipping Weight	Estimated Operating Weight
3,750 lbs	10,085 lbs

WesTech Trips to the Site

Total Trips	Total Days	Includes
1	1	Installation inspection, startup, instruction of plant personnel, and training

Comments/Clarifications

- Availability of equipment components specified may dictate substitutions of equal quality at the discretion of WesTech.
- All hardware is crated and shipped to the jobsite for assembly by the contractor.

Note: Any Item Not Listed Above to Be Furnished by Others.

Items Not Furnished by WesTech

- Unloading of equipment from delivering carrier, protected storage of equipment, installation, supervision of installation
- All items crosshatched on photocopies of engineer's design
- All underground and interconnecting piping, pipe supports, wall inserts or sleeves, Dresser or flexible couplings, hangers, air release piping and valves, sampling lines and sinks, field work of piping (i.e., drilling and tapping for instrumentation) and flow meters
- Walkways, handrails, stairways and ladders
- All chemical feeders, feed lines, chemicals, labor and procedures for the disinfection of equipment, laboratory test equipment
- Structural design, supply and installation of concrete pads, rebar, anchors, concrete, grout and sealant
- Motor control center, motor starters, disconnects, electrical wiring and conduit, telemetering equipment, supports for controls
- Any equipment and service not listed in this proposal

Clarifications and Specification Deviations

This Page Intentionally Blank

Clarifications

All items that are not specifically noted in the enclosed drawings as being supplied by WesTech are by others.

Please assist us by avoiding re-submittal requests if at all possible. If a question or misunderstanding occurs that will not allow us an “approved as noted” consideration, we request that you email or fax us a list of your concerns while keeping our submittal in your possession. We will promptly address the issues, thus avoiding the cost and time delay of a re-submittal.

1. Please check all orientations, elevations, and dimensions shown on enclosed drawings against plans and existing items to assure correct fit-up and assembly to existing equipment and structures not supplied by WesTech Engineering, Inc. Please contact project engineer or project manager if interferences or discrepancies exist.
2. Materials of construction are Type 3000 or 5000 series aluminum plates with Type 6061 aluminum structural members. Assembly and mounting hardware is Type 18-8 stainless steel.
3. Please note location of attachments, nozzles, and manways on top of equipment to help eliminate potential interference with building or overhead equipment.
4. It is recommended that the installing contractor provide an appropriate coating or product barrier for aluminum surfaces in contact with concrete or mortar to prevent corrosion.
5. The Aerator blower included with this scope is designed for a 480 volt, 3 ph, 60 Hz power supply. If the requirements are different, please note corrected voltage and phase on the returned submittal.
6. The nozzles on the equipment are not designed to support the weight of the piping to be attached to the equipment. Piping supports are to be supplied by others.
7. It is recommended that a delay timer be used to keep the blower running for at least 10 minutes after the pump stops. This is to dry the unit out to prevent icing of the outlet screens in colder climates.

Specification Deviations

A conscientious effort has been made to meet the requirements and intent of the consulting engineer's plans and specifications when provided. Occasionally deviations or clarifications are required. The intent of this section is to specifically address direct deviations to the specifications and/or address issues of question between scope of equipment being supplied and as described in specifications.

The specifications supplied by the consulting engineer for design of the equipment have been attached with a line by line review.

The purpose of this Specification Review is to clarify any deviations or exceptions that WesTech is taking to the specification. All items which are marked with a check (✓) should be considered as “No exceptions taken.” This review is also used by WesTech to clarify specifications which might be vague or have multiple interpretations.

May 2019

Project 201800344

Citizens Water
WR-3 VOC Reduction

SECTION 11500 – ALUMINUM FORCED DRAFT AERATOR

PART 1 - GENERAL

✓ 1.1 DESCRIPTION

A. Scope

1. Furnish and install one (1) aluminum forced draft aerator
2. The Contractor shall provide all labor, materials, equipment and incidentals as shown, specified and required to furnish, install and test the aeration equipment complete with piping, internals and appurtenances.
3. In order to assure the highest quality control, the equipment supplier and manufacturer shall be one in the same.

B. Codes, Specifications and Standards

1. Work shall be done in accordance with applicable state and local codes, rules and ordinances, including but not limited to:
 - a. Ten States Standards -- Recommended Standards for Wastewater Facilities, Great Lakes – Upper Mississippi River Board of State and Provincial Public Health and Environmental Management (latest Edition)
 - b. Indiana Department of Environmental Management 327 IAC 8
 - c. American Water Works Association

C. Abbreviations

1. ANSI – American National Standards Institute
2. ANAB – ANSI National Accreditation Board
3. AIAO-BAR – American International Accreditation Organization – Bureau of Accredited Registrars
4. AMCA – Air Movement and Control Association
5. ISO – International Standards Organization

1.2 GENERAL REQUIREMENTS:

- A. The equipment shall consist of one (1) Model AWF210 Aluminum Forced Draft Aerator with associated equipment to comprise a complete system. The unit shall oxidize dissolved iron and reduce levels of dissolved gases such as carbon dioxide, hydrogen sulfide, radon, etc. from the raw water.
- B. Acceptable Manufacturer's: General Filter™ Products - Model AWF210 Aluminum Forced Draft Aerator as manufactured by WesTech Engineering, Inc.
- C. The unit shall be for treating raw water of the following approximate characteristics at a flow rate between 1,230 to 1,600 GPM:

Parameter	Concentration
Alkalinity	331 mg/L
Iron	0.335 mg/L

11500 - 1

ALUMINUM FORCED DRAFT AERATOR

• Model to be AWF310 (3 designates loose fill media).

• Design flow to be 1300 GPM—1600 GPM, per as sold proposal.

Parameter	Concentration
Manganese	0.117 mg/L
Total Hardness (calc)	509 mg/L
cis-1,2-Dichloroethene	1.7 ug/L
Tetrachloroethene	<0.50 ug/L
Trichloroethene	5.44 ug/L
Vinyl Chloride	<0.50 ug/L

- ✓ D. The aerator manufacturer shall have a proven record of design and manufacture of aerators containing loose fill media and stainless steel grids and shall demonstrate experience by providing a listing of at least five installations of loose fill media aerators which have been in service a minimum of 10 years. Manufacturers who cannot meet this experience requirement will not be considered.

✓ 1.2 QUALITY ASSURANCE

- A. The equipment supplier shall be ANAB-accredited ISO 9001 quality system certified. AIAO-BAR accredited systems are not a recognized equivalent. The quality procedures shall provide for a means of qualifying all sub-vendors and shall specify that the fabrication facility is a critical vendor and shall require inspection. The quality system shall be audited on-site by a third-party independent registrar at least annually. Certification shall remain in effect throughout the project start-up.
- B. Perform field testing as specified in this Section.

✓ 1.3 PRODUCT DELIVERY, STORAGE AND HANDLING

- A. Comply with the pertinent provisions of the delivery schedule.
- B. Equipment and materials to be shipped F.O.B. shipping points, with freight prepaid to the jobsite. Fabricated parts when delivered to the site shall be stored off the ground and protected from weather and damage. Control and electrical devices shall be stored indoors.
- C. Ship fabricated assemblies in largest sections permitted by carrier regulations. Match-mark all sections for ease of field installation
- D. Handle so as to prevent damage to equipment during handling and transportation.

✓ 1.4 JOB CONDITIONS

All work must be accomplished within the constraints of the construction schedule as specified. All work shall be scheduled with the Owner and Engineer.

✓ 1.5 SUBMITTALS

- A. Approval Drawings: Submit six sets for approval of the following:
1. Approval drawings showing dimensions, construction and installation details, materials used, and shipping and operating weights.
 2. Manufacturer's literature and catalog cuts of purchased items.
 3. Show evidence of being able to provide the quality of equipment and services described in this specification, the equipment supplier shall submit their ANAB-accredited ISO 9001

quality system certification. AIAO-BAR accredited systems are not a recognized equivalent and are therefore specifically prohibited. The quality procedures shall provide for a means of qualifying all sub-vendors and shall specify that the fabrication facility is a critical vendor and shall require inspection. The quality system shall be audited on-site by a third-party independent registrar at least annually. Certification shall remain in effect throughout the project start-up.

- B. Installation, Operation & Maintenance Manuals: Submit three copies in electronic format and three copies in hard copy format, each including the following:
 1. Complete manufacturer's installation instructions with detailed installation drawings.
 2. Complete manufacturer's operational instructions.
 3. Complete manufacturer's maintenance instructions with complete catalog information, electric motor information, parts list, recommended spare parts list and instructions for periodic maintenance of the aeration unit.
 4. All printed in black and white, bound in white three-ring binders.

This information shall be provided to the Contractor and Engineer at least two weeks prior to the shipment of the equipment.

PART 2 - SCHEDULE OF EQUIPMENT AND MATERIALS

2.1 AERATOR CHAMBER

A. Provide one – 1,300 gpm, General Filter Products Model AWF210 square aluminum forced draft aerator as manufactured by WesTech Engineering, Inc. The aerator shall consist essentially of a closed chamber for affecting a countercurrent flow of water and air. The aerator cover shall be fixed with top and bottom side ports provided for loose plastic fill installation and removal





• Model to be AWF310 (3 designates loose fill media).

- ✓ B. The aerator internal shell chamber shall be 96 inches wide x 96 inches long x 120 inches high and have an effective internal cross sectional area of 64 square feet. The unit shall be of welded construction and fabricated from aluminum alloy 3000 series plate suitably reinforced with Type 6061 aluminum alloy structural members.
- ✓ C. The aerator shall be welded inside and outside with fillet welds equal in size to the thickness of the plates. Appropriate water-retaining welds shall be checked at the factory with dye penetrant before shipment to ensure they are watertight.
- ✓ D. Four structural support legs shall be welded to the base of the aerator chamber. The support legs shall be fabricated of the same materials of construction as the aerator chamber. The support legs shall be equipped with mounting holes for anchorage to tank, platform, base, etc., by others.
- ✓ E. The aerator shall have a 12 inch flanged top side influent connection and a 14 inch plain end effluent connection. Piping and pipe supports to and from the aeration connections is furnished by others.
- ✓ F. Provide proper size air opening and angle frame for mounting of transition section between the air blower and the aerator. The internal hood shall be down turned to prevent the escape of water through the air inlet opening into the blower housing.
- ✓ G. Provide an air seal mounted internally on the water effluent.

 2.2 INTERNALS

- A. A complete primary distribution system of non-corrosive water distributors and air collectors shall be provided for uniform distribution of the inlet water over the horizontal cross section of the aerator chamber and for uniform collection of exhaust air. The distributor box shall be constructed of aluminum with an inlet water velocity breaker box to absorb excess inlet flow energy prior to uniform cascade distribution, aluminum air exhaust stacks engineered and positioned for uniform air distribution through the secondary aeration chamber and water distribution target nozzles. Aluminum shall be alloy 3000 series, same as shell construction.
- B. The distributor box shall be equipped with polypropylene inlet water distribution nozzles having an approximate 6" center to center spacing. The nozzles shall be equipped with a bell mouthed entrance to minimize operating head. Each nozzle shall be equipped with an integral target distributor located below the nozzle which, in conjunction with the other target nozzles, shall uniformly disperse and distribute all the inlet flow over the entire cross section of the aerator chamber. Use of a pipe inlet header with orifices or spray nozzles, commonly referred to as spray aerators, **is not permitted** because of inadequate inlet water distribution and excessive head loss required.
- C. The secondary aeration zone shall consist of 5 foot depth of loose plastic fill with aluminum supporting grid.

2.3 FORCED DRAFT BLOWER ASSEMBLY

- A. Provide a motor blower with an air flow capacity of 4,800 scfm and sufficient static pressure, driven by a 2 hp, 208-230/460 volt, 3-phase, 60 Hz motor. The motor shall be provided with a weatherproof hood. Provide protective #24 mesh stainless steel screen on aluminum blower inlet hood and an aluminum transition for connecting blower to aerator. Dampers installed in blower discharge creating a false head are not acceptable.
-  B. The blower shall be of the non-overloading centrifugal type. The blower housing shall be constructed of heavy steel properly reinforced. The blower wheel shall be of welded construction and shall be dynamically balanced. Bearings shall be anti-friction, self-aligning, grease packed, pillow block type with grease and dirt seal.
-  C. The blower rating shall be based upon the AMCA standards and the blower shall bear the AMCA seal.
-  D. Supporting platform for the aerator and blower and the necessary materials for securing aerator against wind loads shall be provided (by purchaser) (under the general contract).
-  E. The Motor Control Center (MCC) supplier shall provide a delay timer be used to keep the blower running for at least 10 minutes after the pump stops. This is to prevent water from running back into the blower during shutdown and to dry the unit out to prevent icing of the outlet screens in colder climates.
-  F. It is recommended that a soft start motor starter be provided in the Motor Control Center (MCC) for the forced draft blower. This is to reduce the load on the drive system when starting up the drive. Aerator controls and timers are not by WesTech Engineering, Inc.

- ✓ G. The blower manual or automatic starters, disconnects, wiring and conduit to the blower leads is to be supplied by the electrical subcontractor.

- ✓ 2.4 AIR EXHAUST HOOD/MOISTURE SEPARATORS

- A. An aluminum air exhaust hood with stainless steel screen and baffle type moisture separators shall be provided for mounting on the aerator cover. The hood shall be constructed of aluminum properly braced with aluminum angles to withstand wind loads. The air outlet shall be screened with #24 stainless steel mesh. Provide moisture separator baffles designed to produce multiple changes of direction in the exhaust air stream at the base of the hood. Moisture separator baffles are to be constructed of 20 gauge aluminum and are to be spaced on 1 1/2 inch centers.

- ✓ 2.5 TOP INSPECTION PORT

- A. Provide one factory installed inspection port approximately 18 inch diameter in the aerator cover for inspection of the distributor box and the top trays which are visible through the air stacks.

- 2.06 BOTTOM INSPECTION PORT

- A. Provide two (2) factory installed inspection ports 13 inches x 15 inches in the side shell below the media for inspection of the lower collection area and to view the internals from below.

- ✓ 2.07 FINISH

- A. Surfaces in contact with concrete or other dissimilar metal is shipped bare metal for field placement onto a coal tar or mastic base pad coating (provided and installed by contractor).
- B. All manufactured aluminum and stainless steel shall receive factory handling care during fabrication to prevent discoloration, gouges or scarring. Oil, grease, protective mill coatings, and other soluble contaminants should be removed at the factory by solvent cleaning with solvents or commercial cleaners by wiping down or pressure washing.

- ✓ PART 3 - EXECUTION AND PERFORMANCE

- 3.1 INSTALLATION INSPECTION, START-UP AND OPERATOR TRAINING

- A. The Supplier shall furnish a qualified factory-trained field technician for equipment check, start-up and instruction of operating personnel on proper operation and maintenance of the equipment, with a maximum of one eight hour day at the jobsite in one trip.
- B. Installation inspection, start-up and operator instruction shall be coordinated with the Installing Contractor. All equipment must be in operating condition and ready for Supplier's Field Technician when called to the project location.
- C. Effluent quality laboratory analysis shall be provided by the Owner.

- ✓ 3.2 WARRANTY

- A. A warranty shall be provided covering all materials and workmanship for twelve months from the initial startup or eighteen months from delivery, whichever occurs first.

• WesTech standard design has one (1) lower inspection port and one (1) upper inspection port.

May 2019

Project 201800344

Citizens Water
WR-3 VOC Reduction

END OF SECTION 11500

11500 - 6

ALUMINUM FORCED DRAFT AERATOR

Section Four: Mechanical Drawings

This Page Intentionally Blank

Mechanical Drawings

Please check all elevations and dimensions shown on enclosed drawings against plans and existing items to assure correct fit-up and assembly to existing equipment and structures not supplied by WesTech Engineering, Inc.

If interferences or discrepancies exist, please contact project engineer or project manager.

Drawing Number	Description
1-47949	Mechanical Aeration

This Page Intentionally Blank

PROJECT COVER SHEET

PROCESS DESIGN INFORMATION		
DESIGN FLOW:	1,300	GPM
DESIGN WATER TEMPERATURE:	68	°F
DESIGN REMOVAL OF:	IRON AND DISSOLVED GASSES	

NOTES:

1. 1 UNIT TOTAL.
2. WORKS WITH DRAWING 1-47949.

PREPARED FOR	WHITE RIVER WELL 3 VOC REMOVAL INDIANAPOLIS, INDIANA
CUSTOMER	
ENGINEER	AMERICAN STRUCTUREPOINT INC. INDIANAPOLIS, INDIANA
CONTRACTOR	BOWEN ENGINEERING CORPORATION. INDIANAPOLIS, INDIANA
PO/CONTRACT NUMBER	1630256

**BACKCHARGES FOR FIELDWORK OF ANY KIND ARE NOT
ACCEPTABLE WITHOUT PRIOR WRITTEN AUTHORIZATION
BY WESTECH ENGINEERING, INC.**

REV	REVISION DESCRIPTION	ECN	DESIGNER	APPROVER	DATE



THIS DRAWING IS PROPERTY OF WESTECH ENGINEERING, INC. AND IS TRANSMITTED IN CONFIDENCE. NEITHER RECEIPT NOR POSSESSION CONFERS OR TRANSFERS ANY RIGHTS TO REPRODUCE, USE, OR DISCLOSE IN WHOLE OR IN PART, DATA CONTAINED HEREIN FOR ANY PURPOSE WITHOUT THE WRITTEN PERMISSION OF WESTECH ENGINEERING, INC.

TITLE	MECHANICAL AERATION FORCED DRAFT AERATOR 96IN SQ X 120IN HIGH, LF, 0.900, PE, 1600 GPM, 4800 CFM MAX				
DESIGNER	CHECKER	APPROVER	DATE		
PR63	JO48	JO48	2019 - 08 - 23		
DOCUMENT NUMBER				SHEET	REV
23925A-1000				1 OF 1	-

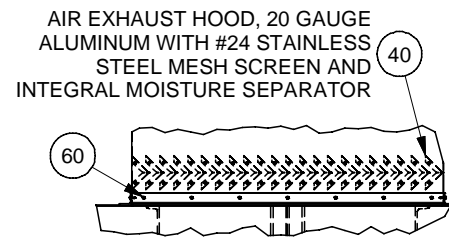

DETAIL C

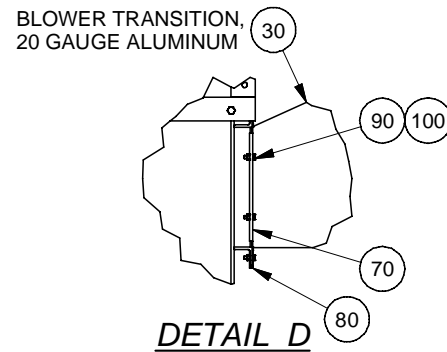

DETAIL D

BILL OF MATERIAL							
PIECE	UNIT QTY	PART NO	DESCRIPTION	MATERIAL	LENGTH	WIDTH	TOTAL WT, LB
10	1	1-47951	AERATOR ASSEMBLY, FORCED DRAFT, 96 SQ, 120 HIGH, LF, 0.900, PE				2815.1
20	1	2-29119	BLWR,HVAC;CENT;BELT DRIVE;#10 ARG;182H;4800SCFM	STL			310.0
30	1	1-5574	TRANSITION, FD BLOWER, MODEL 182, 25 DEEP	3003-H14			10.0
40	1	1-10224	HOOD, EXHAUST FD, SCREENED 15 x 39				20.0
50	1	1-9150	HOOD, SCREENED, FD BLOWER INLET, MODEL 182				10.5
60	42	2-8857	SCREW, SHT METAL, PAN HD, PHILLIPS, NO 8 x 0.75	18-8			0.2
70	2	1-10249	CHANNEL, TRANSITION, DRILLED, 9	3003-H14			0.2
80	2	1-10258	CHANNEL, TRANSITION, DRILLED, 52.75	3003-H14			1.1
90	12	2-6320	CAP SCR, HEX, 0.25-20UNC x 0.75, FULL THREAD	304			0.2
100	12	2-5882	NUT, HEX, 0.25-20UNC	304			0.1
110	320	2-14356	MEDIA, LOOSE FILL, 3.25, CYLINDRICAL	PP			896.0
120	6	2-16476	ADHSV/SEALANT;PERMATEX	SILICONE			6.0

APPROX. TOTAL WEIGHT (LB)
4070.4

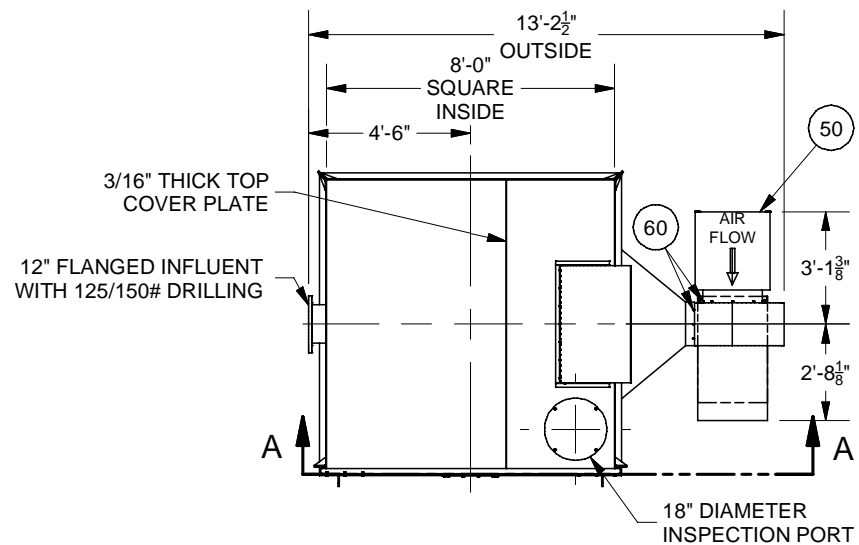

PLAN

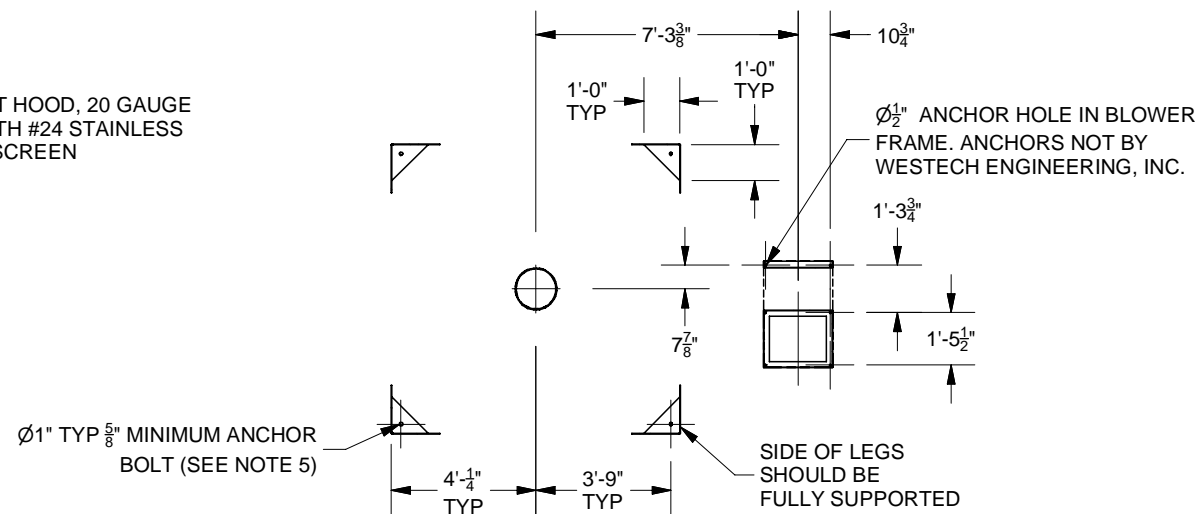

SECTION B-B

NOTES:

- 1.) AERATOR IS SHIPPED FULLY ASSEMBLED EXCEPT FOR SOME AIR HANDLING EQUIPMENT, HARDWARE, AND SEALANT. REFER TO BILL OF MATERIAL FOR IDENTIFICATION OF FIELD ASSEMBLED ITEMS.
- 2.) AERATOR SHIPS WITHOUT ALL PORT COVER HARDWARE INSTALLED TO AID IN MEDIA LOADING. REMAINING CAP SCREWS AND SEALANT FOR PORT COVERS ARE SHIPPED LOOSE.
- 3.) ALL AERATOR PLATE IS TO BE SERIES 3000 OR 5000 ALUMINUM. STRUCTURALS TO BE 6061 ALUMINUM.
- 4.) THE AERATOR SHALL BE WELDED INSIDE AND OUTSIDE WITH FILLET WELDS EQUAL TO THE THICKNESS OF THE PLATES. ALL MAIN HOUSING SEAM WELDS SHALL BE DYE PENETRANT CHECKED AT THE FACTORY BEFORE SHIPMENT TO ENSURE THEY ARE WATERTIGHT.
- 5.) THE MAXIMUM ANCHOR BOLT DIAMETER IS 7/8". THE MINIMUM WASHER DIAMETER IS 2" FOR ALL ANCHOR SIZES. ANCHORAGE IS BY OTHERS.
- 6.) FLANGE BOLT HOLE PATTERN IS TO STRADDLE UNIT CENTERLINE.
- 7.) AERATOR INLET AND EFFLUENT PIPE STUBS ARE NOT DESIGNED TO SUPPORT INLET AND EFFLUENT PIPING. ADDITIONAL PIPE SUPPORTS SHOULD BE USED BUT WILL BE SUPPLIED BY OTHERS.
- 8.) INFLUENT AND EFFLUENT PIPE MOUNTING HARDWARE AND GASKETS ARE PROVIDED BY OTHERS.
- 9.) IF INSTALLATION INSTRUCTIONS ARE NOT CLEARLY UNDERSTOOD, CONSULT WESTECH ENGINEERING, INC. FOR ADDITIONAL INFORMATION BEFORE COMMENCING ERECTION.
- 10.) IMPROPER STORAGE, HANDLING, INSTALLATION, OR FIELD MODIFICATIONS OF EQUIPMENT MAY RESULT IN DAMAGE AND LOSS OF WARRANTY PROTECTION.
- 11.) THE BLOWER MOTOR MUST BE WIRED CORRECTLY TO THE VOLTAGE LISTED ON THE UNIT.
- 12.) PLACE 3/8" BEAD OF BLUE PERMATEX SEALANT ON PORT COVERS INSIDE OF BOLT PATTERN BEFORE INSTALLING BOLTS.
- 13.) AERATOR MEDIA SHIPPED LOOSE FOR FIELD INSTALLATION.

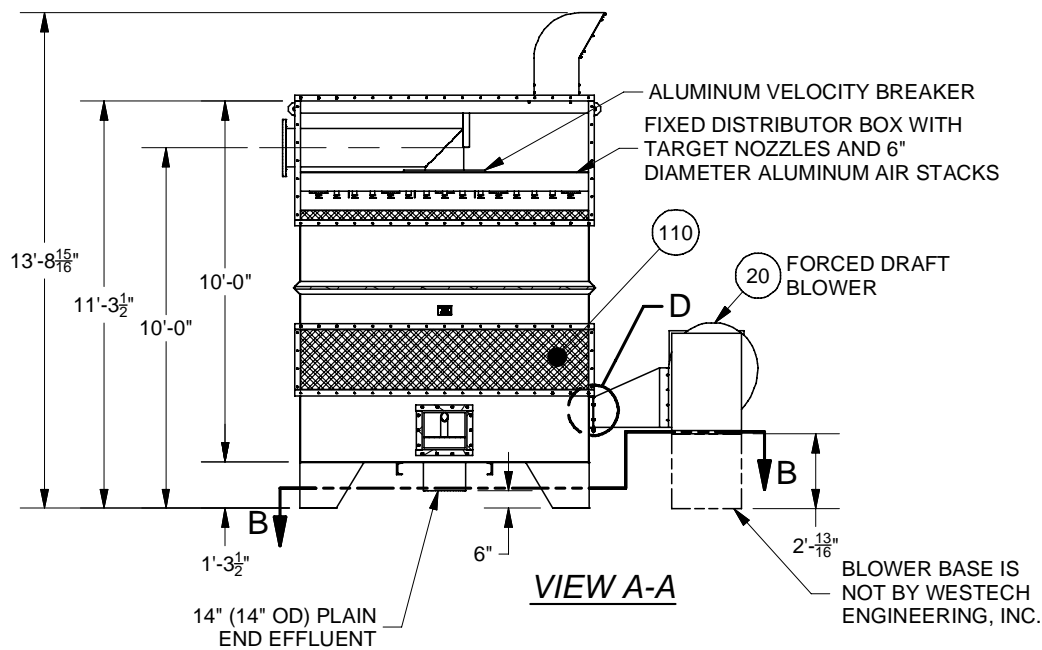

VIEW A-A

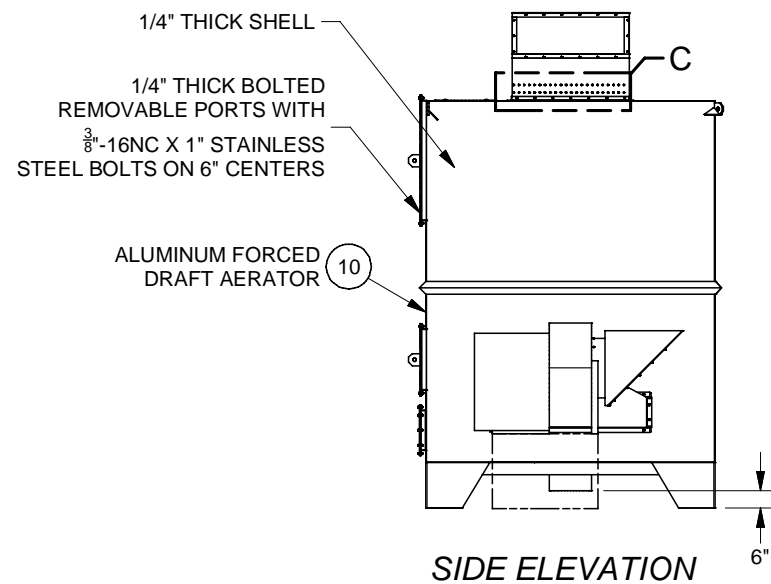

SIDE ELEVATION

REV	REVISION DESCRIPTION	ECN	DESIGNER	APPROVER	DATE

Westech			
THIS DRAWING IS PROPERTY OF WESTECH ENGINEERING, INC. AND IS TRANSMITTED IN CONFIDENCE. NEITHER RECEIPT NOR POSSESSION CONFERS OR TRANSFERS ANY RIGHTS TO REPRODUCE, USE, OR DISCLOSE, IN WHOLE OR IN PART, DATA CONTAINED HEREIN FOR ANY PURPOSE, WITHOUT THE WRITTEN PERMISSION OF WESTECH ENGINEERING, INC.			
TITLE MECHANICAL AERATION			
FORCED DRAFT AERATOR			
96IN SQ X 120IN HIGH, LF, 0.900, PE, 1600 GPM, 4800 CFM MAX			
DESIGNER	CHECKER	APPROVER	DATE
PR63	JO48	JO48	8/21/2019
DOCUMENT NUMBER			SHEET
1-47949			1 OF 1
REFERENCE DOCUMENTS			REV
			-

Section Five: Mechanical Component Data Sheets

This Page Intentionally Blank

Mechanical Component Data Sheets

Please note voltages and power requirements for components being supplied.

Wiring, motor starters, conduit and air supply piping to components are not supplied by WestTech unless noted.

Drawing Number	Description
23925A-DS01	Forced Draft Blower Scope of Supply
23925A-DS02	Aeration Media Scope of Supply

This Page Intentionally Blank

CATALOG & BULLETIN INFORMATION

FOR

Forced Draft Blower Scope of Supply

Quantity	Volume	Pressure	Model	Motor
1	4,800 scfm	3/8 in SP	B182	2 hp, 480 V, 60 Hz, 3 ph, TEFC
Feature	Notes			
Housing	Reinforced heavy steel blower housing with weatherproof motor hood (Anchor bolts are not by WesTech.)			
Blower Wheel	Dynamically balanced welded steel			
Bearings	Anti-friction, self-aligning, grease packed, pillow block type with grease and dirt seal			
Drive	Adjustable V-belt			
Paint	Manufacturer's standard factory primed			

Note: Blower motor starters are not part of WesTech Aeration Equipment supply.

REV	REVISION DESCRIPTION	ECN	DESIGNER	APPROVER	DATE
THIS DRAWING IS PROPERTY OF WESTECH ENGINEERING, INC. AND IS TRANSMITTED IN CONFIDENCE. NEITHER RECEIPT NOR POSSESSION CONFERS OR TRANSFERS ANY RIGHTS TO REPRODUCE, USE, OR DISCLOSE IN WHOLE OR IN PART, DATA CONTAINED HEREIN FOR ANY PURPOSE WITHOUT THE WRITTEN PERMISSION OF WESTECH ENGINEERING, INC.					
DESIGNER	JO48	TITLE CATALOG & BULLETIN INFORMATION FORCED DRAFT BLOWER SCOPE OF SUPPLY CLIENT WHITE RIVER WELL 3 VOC REMOVAL INDIANAPOLIS, INDIANA			
CHECKER	JO48				
APPROVER	JO48				
DATE	08/23/2019				
FILE: 23925A-DS01-FORCED DRAFT BLOWER SCOPE OF SUPPLY.docx		PROJECT 23925A	DOCUMENT NUMBER 23925A-DS01	SHEET 1 OF 1	REV -

**PEERLESS
BLOWERS**

Ultrafan-Pak 2000

**Non-Overloading Belt Drive
Arrangement 10**

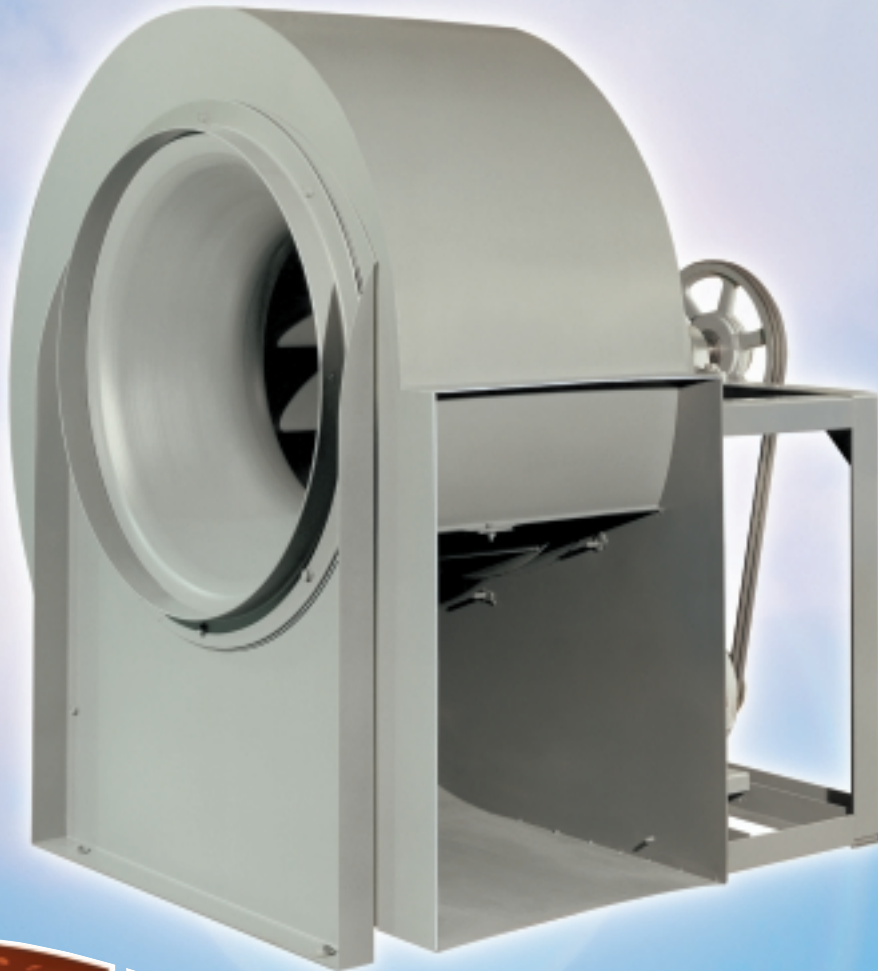

Your Clean Air Source!

PEERLESS BLOWERS

PEERLESS BLOWERS ULTRAFAN-PAK 2000

HIGH QUALITY... HIGH EFFICIENCY... VERSATILITY

PEERLESS BLOWERS ULTRAFAN-PAK 2000 INDEX

Peerless Blowers Ultrafan-Pak 2000	2
Ultrafan-Pak 2000 Construction Features	2
Material Specifications Class 1 and Class 2	3
Heavy Duty Anti-Friction Bearings	3
Ultrafan-Pak 2000 Accessories	4
Spark-Resistant Standards	4
Peerless Blowers Ultrafan-Pak 2000 Performance Tables	
B-105	5
B-122	6
B-135	7
B-150	8
B-165	9
B-182	10
B-200	11
B-222	12
B-245	13
B-270	14
B-300	15
B-330	16
B-365	17
Peerless Blowers Ultrafan-Pak 2000 Arrangement #10 Class 1	18
Peerless Blowers Ultrafan-Pak 2000 Arrangement #10 Class 2	19

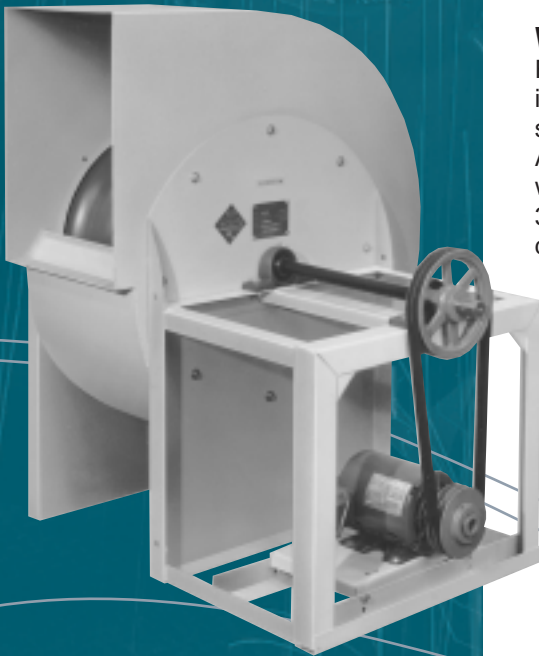

Established in 1893, **Peerless Blowers** has a well established record of manufacturing a complete line of heavy-duty industrial fans and blowers, as well as propeller fans for commercial and industrial applications. For over a hundred years, thousands of customers have come to know and depend on the quality-built, reliable and efficient fans and blower products produced by **Peerless Blowers**.

Our engineering and design departments are experts assisting customers develop custom-designed air conveying systems that will meet and exceed their critical fan or blower application requirements.

Fans and blower products manufactured by **Peerless Blowers** have and continue to provide exceptional performance, cost-efficient operation and long-term service to customers in numerous OEM,

commercial and industrial markets, including:

- Aviation • Automotive • Chemical
- Clothing • Food • Foundries
- Graphics/Printing • HVAC • Leather
- Maintenance • Manufacturing
- Mining • Paint • Paper/Pulp
- Petroleum • Plastics • Rail • Rubber
- Steel • Textile • And More!

Fans and blowers produced by **Peerless Blowers** have been application engineered and designed to meet and exceed all the requirements of today's air moving needs. Tested/rated to meet AMCA/ASHRAE Codes, our blowers are designed to provide maximum performance, long-term service and cost efficient operation in a wide variety of applications and environments.

Regardless of your air movement requirements, Peerless Blowers ...IS YOUR CLEAN AIR SOURCE!

ULTRAFAN-PAK 2000 BLOWER CONSTRUCTION FEATURES

Wheels

Flat Blade Wheel — backwardly inclined non-overloading wheels standard on sizes 105 thru 245.
Airfoil Wheel — backward curved airfoil wheels standard on sizes 270 thru 365. All wheels are statically and dynamically balanced.

Inlet

Circular stamped ring. Rigid streamlined inlet.

Frame

All welded steel construction. Easy access to motor for servicing.

Housing

All are convertible and may be rotated easily to any of eight 45° positions.

Motor Base

Heavy construction assures sturdy base for motor mounting and features easy adjustment for belt tension.

Bearings

Self-aligning ball bearing pillow blocks. These bearings are designed to operate under the most severe atmospheric conditions.

Shaft

Ground and polished solid steel key-wayed on each end.

Motor

Commercial standard Fan and Blower duty motors are job-matched to each requirement. All types of current characteristics, enclosures and bearing construction are available.

Adjustable V-Belt Drive

High quality CAST Iron adjustable pitch motor sheaves are standard equipment. V-Belts with ample service factor are also employed. When performance data is specified, the blowers are factory set to exact blower speed to meet job requirements. Constant speed drives are also available.

MATERIAL SPECIFICATIONS CLASS 1 AND CLASS 2

FAN SIZE	WHEEL DIAMETER	SHAFT DIAMETER		HOUSING GAUGES		NO. OF BLADES	WHEEL GAUGES				FRAME GAUGES	
		CLASS 1	CLASS 2	BAND	FACE		BLADES			END RING	DRIVE	INLET
							BACK PLATE	CLASS 1	CLASS 2			
105	10 1/2	3/4	1	20	16	12	10	12	10	14	16	—
122	12 1/4	1	1 3/16	16	16	12	3/16	12	3/16	14	14	16
135	13 1/2	1	1 3/16	16	14	12	3/16	12	3/16	14	14	16
150	15	1	1 3/16	16	14	12	3/16	12	3/16	14	14	16
165	16 1/2	1	1 3/16	16	14	12	3/16	10	3/16	14	14	16
182	18 1/4	1 3/16	1 3/16	16	14	12	3/16	10	3/16	14	14	14
200	20	1 3/16	1 7/16	14	14	12	3/16	3/16	3/16	14	12	14
222	22 1/4	1 3/16	1 11/16	14	12	12	3/16	3/16	10	14	12	14
245	24 1/2	1 7/16	1 11/16	14	12	12	3/16	3/16	10	14	12	12
270	27	1 7/16	1 11/16	14	12	11	3/16	16	16	14	12	12
300	30	1 11/16	1 15/16	14	12	11	3/16	16	16	14	12	12
330	33	1 11/16	1 15/16	14	12	11	1/4	16	16	14	10	10
365	36 1/2	1 15/16	2 3/16	12	10	11	1/4	16	16	14	10	10

HEAVY DUTY ANTI-FRICTION BEARINGS

ULTRAFAN-PAK 2000 Blowers are equipped with self-aligning single row ball bearings.

Computerized selections have been made on all bearings based on radial, thrust and combined loads to give 100,000 average life hours (AFMBA L₅₀) on standard units at the maximum design of each blower.

Bearings selected have effective seals to retain the lubricant and to prevent against contamination. All have grease fittings for relubrication. Bearings are available for 400,000 Hours (AFMBA L₅₀).

The table at right shows the type bearings used for each unit.

Peerless Blowers reserves the right to change bearings of equal ratings.



FAN SIZE	STANDARD 100,000 HOURS	SPECIAL 400,000 HOURS
105	A	A
122	A	B
135	A	B
150	A	C
165	A	C
182	A	C
200	A	C
222	A	C
245	A	C
270	A	C
300	A	C
330	A	C
365	A	C

PEERLESS BLOWERS ULTRAFAN-PAK 2000

Peerless Blowers are built with these features:

Class 1 performance cataloged to 5" WG static pressure. Class 2 performance cataloged to 8.5" WG static pressure. Air delivery ranges from 509 CFM to 32,172 CFM.

Non-overloading performance — the backwardly inclined blade wheel gives a brake horsepower that levels off at a point to allow economical selection of motors that will not overload if

system pressure drops. The top four sizes have airfoil blades.

Easy installation and maintenance — the self-contained, completely packaged units allow easy access to motor, drive and bearings for ease in installation, lubrication, belt adjustment and wiring.

Rugged construction—heavy gauge all-welded steel construction. Discharge position on all sizes may be rotated to any of eight 45° positions.

CERTIFIED PERFORMANCE RATINGS

Peerless Blowers certifies that the "ULTRAFAN-PAK 2000" Blowers shown herein are licensed to bear the AMCA Seal. The ratings shown are based on tests and procedures performed in accordance with AMCA Publication 211 and comply with the requirements of the AMCA Certified Ratings Program.



PEERLESS BLOWERS ULTRAFAN-PAK 2000 ACCESSORIES

1. Weather Cover

Covers entire drive side frame and motor. Eliminates need for penthouse or other protection outdoors. Fastens securely with screws.



Drive Cover

2. Belt Guard

Covers the drives and entire frame end. Constructed of heavy gauge expanded metal mesh with welded steel frame.

Securely fastened with screws to blower frame.

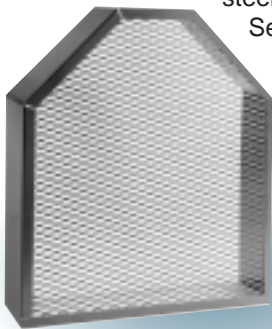

Belt Guard

3. Automatic Discharge Shutter

Self-contained in adapter sleeve and securely attached to fan discharge. All materials resistant to weather corrosion. Constructed to prevent backdrafts and entrance of rain and snow.

Discharge screens are not available with shutters.



Shutter

4. Clean-Out Doors

Bolted Door—Removable door for ease of cleaning and inspection. Bolted to housing with hex head bolts and gasketed for tight seal.

Quick-Opening Door—Held in Place with pressure latches, hinged at the bottom and gasketed.

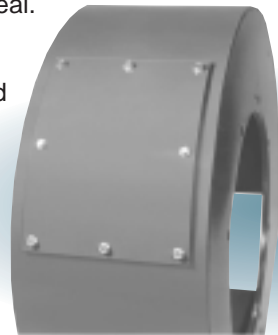

Bolted Door



Quick-Opening Door

5. Vibration Rail Bases

Shock mounting rubber-in-shear rails or pads and spring rails or pads are available as stock items.

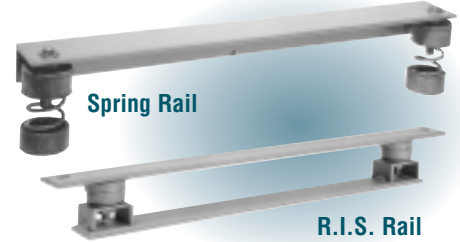

Spring Rail

R.I.S. Rail

6. Other Accessories

All size blowers are available with extra features such as: inlet vanes, drain fittings, inlet or discharge screens, flanged inlets or outlets, and heat slingers. Protective coatings are also available. Also available in spark resistant construction.

Sample specifications for ULTRAFAN PAK 2000 Backward Inclined Units

- Fan shall be single width, single inlet with backward inclined flat blade wheel on size: 105 through 245.
- Airfoil wheel on size: 270 through 365.
- CW or CCW rotation as specified.
- The fan shall be of welded and bolted, heavy gauge steel construction coated with Peerless Blowers' electrostatically applied baked polyester coating. The

housing shall be easily rotated to any of eight standard positions.

- The fan shall have self-aligning ball bearings and the shaft shall be ground and polished solid steel keywayed. The fan shall have a heavy duty, ball bearing motor matched to the fan load and furnished at the specified voltage, phase and enclosure.
- The fan shall have a drive with a cast iron adjustable pitch motor

sheave. The belts shall be oil and heat resistant.

- Fan to be arrangement 10, Class I or Class II construction (as required).
- All fans to be manufactured in an ISO 9001 Certified Facility.
- All fans shall bear the AMCA seal for air performance.
- Fan to be model "B" as manufactured by Peerless Blowers (Hot Springs, NC).

PEERLESS BLOWERS ULTRAFAN-PAK 2000 PERFORMANCE TABLES

B-182

TIP SPEED (FPM) = 4.778 x RPM

OUTLET { 1.899 Sq. Ft. Inside
19 5/8" x 14 1/4" Outside

MAX. HP = .6444 $\left(\frac{\text{RPM}}{1000}\right)^3$

WHEEL DIAMETER—18 1/4"

INLET { 2.02 Sq. Ft. Inside
19 5/8" Dia. Outside

MAX. RPM
CL.1 2044
CL.2 2666

VOL. CFM	OUTLET VEL. FPM	.25 S.P.		.5 S.P.		.75 S.P.		1 S.P.		1.25 S.P.		1.5 S.P.		2 S.P.		2.5 S.P.		3 S.P.		3.5 S.P.	
		RPM	BHP	RPM	BHP	RPM	BHP	RPM	BHP	RPM	BHP	RPM	BHP	RPM	BHP	RPM	BHP	RPM	BHP	RPM	BHP
1519	800	527	0.09	658	0.17	—	—	—	—	—	—	—	—	—	—	—	—	—	—	—	—
1709	900	562	0.11	679	0.19	793	0.28	—	—	—	—	—	—	—	—	—	—	—	—	—	—
1899	1000	599	0.14	705	0.22	809	0.31	911	0.42	—	—	—	—	—	—	—	—	—	—	—	—
2089	1100	638	0.16	736	0.25	831	0.35	925	0.46	1016	0.59	—	—	—	—	—	—	—	—	—	—
2279	1200	677	0.19	769	0.29	857	0.39	944	0.50	1029	0.63	1113	0.77	—	—	—	—	—	—	—	—
2469	1300	718	0.23	805	0.33	886	0.44	967	0.55	1047	0.68	1125	0.82	—	—	—	—	—	—	—	—
2659	1400	759	0.27	842	0.38	918	0.49	993	0.61	1068	0.74	1142	0.88	1286	1.19	—	—	—	—	—	—
2849	1500	801	0.31	880	0.43	952	0.55	1023	0.67	1093	0.81	1163	0.95	1299	1.26	1432	1.62	—	—	—	—
3038	1600	844	0.36	919	0.49	988	0.62	1055	0.74	1121	0.88	1186	1.02	1316	1.34	1442	1.70	—	—	—	—
3228	1700	888	0.42	959	0.55	1026	0.69	1089	0.82	1151	0.96	1213	1.11	1335	1.43	1456	1.79	1574	2.18	—	—
3418	1800	933	0.48	1000	0.62	1064	0.76	1124	0.91	1183	1.05	1242	1.20	1358	1.53	1473	1.89	1586	2.28	1697	2.70
3608	1900	978	0.55	1040	0.69	1103	0.85	1161	1.00	1217	1.15	1273	1.30	1383	1.63	1493	2.00	1601	2.39	1707	2.82
3798	2000	1023	0.63	1082	0.77	1142	0.94	1198	1.09	1252	1.25	1305	1.41	1411	1.75	1515	2.12	1619	2.52	1721	2.94
3988	2100	1068	0.71	1124	0.86	1182	1.03	1237	1.20	1289	1.36	1340	1.53	1440	1.88	1540	2.25	1639	2.65	1738	3.08
4178	2200	1114	0.80	1167	0.96	1222	1.13	1275	1.31	1326	1.49	1375	1.66	1471	2.01	1567	2.39	1662	2.80	1756	3.23
4368	2300	1159	0.90	1210	1.06	1263	1.24	1315	1.43	1364	1.61	1411	1.79	1504	2.16	1596	2.54	1687	2.95	1778	3.39
4558	2400	1204	1.01	1254	1.18	1305	1.36	1355	1.56	1403	1.75	1449	1.94	1538	2.32	1626	2.71	1714	3.12	1801	3.57
4937	2600	1296	1.25	1344	1.44	1389	1.62	1436	1.83	1481	2.04	1525	2.25	1609	2.66	1691	3.07	1772	3.50	1853	3.95
5317	2800	1388	1.53	1434	1.74	1475	1.93	1518	2.14	1562	2.37	1604	2.60	1684	3.04	1761	3.48	1837	3.93	1912	4.39
5697	3000	1481	1.85	1525	2.07	1563	2.28	1603	2.49	1643	2.73	1684	2.98	1760	3.46	1834	3.93	1905	4.40	1976	4.89
6077	3200	1573	2.20	1615	2.45	1653	2.67	1689	2.90	1727	3.14	1765	3.40	1839	3.92	1909	4.42	1977	4.93	2044	5.43
6457	3400	1669	2.63	1706	2.87	1743	3.12	1777	3.35	1811	3.60	1847	3.86	1918	4.41	1986	4.96	2051	5.50	2115	6.03

VOL. CFM	OUTLET VEL. FPM	4 S.P.		4.5 S.P.		5 S.P.		5.5 S.P.		6 S.P.		6.5 S.P.		7 S.P.		7.5 S.P.		8 S.P.		8.5 S.P.	
		RPM	BHP	RPM	BHP	RPM	BHP	RPM	BHP	RPM	BHP	RPM	BHP	RPM	BHP	RPM	BHP	RPM	BHP	RPM	BHP
3988	2100	1834	3.54	1930	4.03	2023	4.54	—	—	—	—	—	—	—	—	—	—	—	—	—	—
4178	2200	1850	3.69	1942	4.18	2033	4.69	2122	5.23	—	—	—	—	—	—	—	—	—	—	—	—
4368	2300	1868	3.86	1957	4.35	2044	4.86	2131	5.40	2216	5.97	—	—	—	—	—	—	—	—	—	—
4558	2400	1888	4.04	1974	4.53	2059	5.04	2143	5.58	2226	6.15	2307	6.74	—	—	—	—	—	—	—	—
4937	2600	1934	4.43	2014	4.93	2094	5.45	2172	6.00	2251	6.57	2328	7.15	2405	7.77	2480	8.40	—	—	—	—
5317	2800	1987	4.88	2062	5.39	2136	5.92	2211	6.47	2284	7.04	2357	7.64	2430	8.25	2502	8.89	2573	9.54	2643	10.22
5697	3000	2046	5.38	2116	5.90	2186	6.44	2256	7.00	2325	7.58	2394	8.19	2463	8.81	2531	9.44	2599	10.10	2666	10.78
6077	3200	2110	5.95	2176	6.48	2241	7.03	2307	7.60	2372	8.19	2438	8.80	2503	9.42	2567	10.07	2631	10.73	—	—
6457	3400	2177	6.57	2240	7.12	2302	7.68	2364	8.26	2425	8.86	2487	9.48	2548	10.11	2610	10.77	—	—	—	—
6836	3600	2248	7.24	2307	7.81	2366	8.39	2425	8.99	2483	9.60	2542	10.23	2600	10.87	2658	11.53	—	—	—	—
7216	3800	2321	7.98	2378	8.57	2434	9.17	2490	9.79	2545	10.41	2601	11.05	2656	11.70	—	—	—	—	—	—
7596	4000	2396	8.76	2451	9.39	2504	10.02	2558	10.65	2611	11.29	2664	11.94	—	—	—	—	—	—	—	—
7976	4200	2473	9.60	2526	10.26	2577	10.92	2628	11.58	—	—	—	—	—	—	—	—	—	—	—	—
8356	4400	2551	10.49	2602	11.19	2652	11.88	—	—	—	—	—	—	—	—	—	—	—	—	—	—
8735	4600	2630	11.44	—	—	—	—	—	—	—	—	—	—	—	—	—	—	—	—	—	—

Performance certified is for installation type B—free inlet, ducted outlet.

Power Rating (BHP) does not include transmission losses.

Performance ratings do not include the effects of appurtenances (accessories).

Data in **bold** face indicates quietest and most efficient performance.

- Class I Blowers
- Class II Blowers

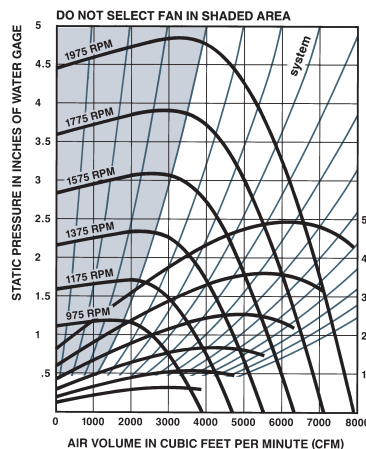

BRAKE HORSEPOWER

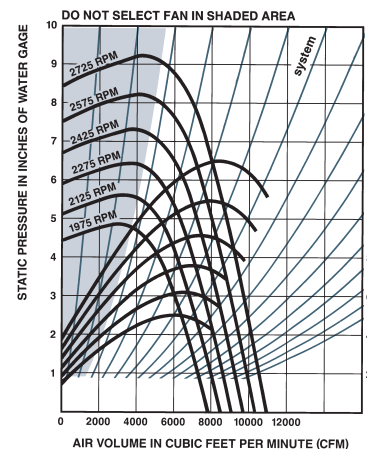

BRAKE HORSEPOWER

PEERLESS BLOWERS ULTRAFAN-PAK 2000 BLOWERS

Non-Overloading Belt Drive — Arrangement #10 — SWSI — Class 1

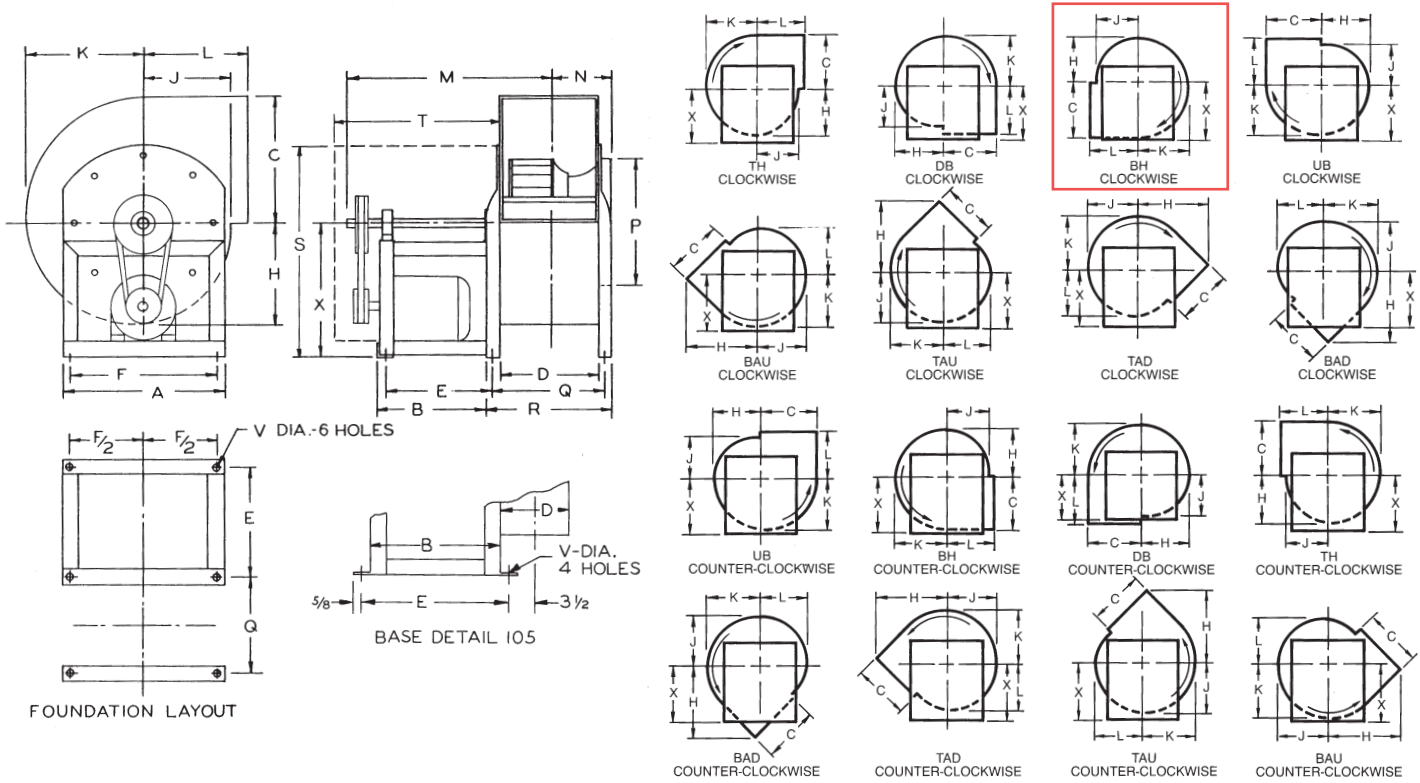

SIZE	WHEEL DIA.	SHAFT DIA.	A	B	C*	D	E	F	TH, DB, BH, UB STRAIGHT DISCHARGE				BAU, TAU, TAD, BAD ANGULAR DISCHARGE				M	N	P	Q	R	S	T	V	X	MAX. MOTOR FRAME
									H	J	K	L	H	J	K	L										
105	10 1/2	3/4	127/8	13	11 3/4	8	14 1/4	10 3/4	7 7/8	6 3/4	9 1/8	8 1/16	13 1/4	8 7/8	9 5/8	7 1/8	19 5/8	6	127/8	—	—	20 1/2	17	7 1/16	14	145T
122	12 1/4	1	163/8	13 1/2	13 1/4	9 5/8	13 1/2	14 3/4	10 1/8	8 1/2	11 1/2	10 1/2	16 5/8	10 3/4	12 1/2	9 1/8	23 7/8	6 3/8	13 1/4	11 1/4	12 3/4	25 1/4	20	1/2	17	182T
135	13 1/2	1	175/8	13 1/2	14 5/8	10 3/4	13 1/2	16	11 1/8	9 3/8	12 5/8	11 3/8	18 1/4	11 7/8	13 3/4	10	24 3/8	7	14 1/2	12 3/8	13 7/8	25 7/8	20	1/2	17	182T
150	15	1	19 1/4	15 1/2	16 1/4	11 3/4	15 1/2	17 5/8	12 3/8	10 3/8	14 1/8	12 3/8	20 1/8	13 1/4	15 1/4	11 1/8	26 7/8	7 1/2	16 1/8	13 3/8	14 7/8	27 5/8	22	1/2	17 7/8	182T
165	16 1/2	1	21 3/8	15	17 3/4	13	15 1/2	19 3/4	13 5/8	11 3/8	15 1/2	13 3/8	21 7/8	14 5/8	16 3/4	12 1/4	27 1/2	8 1/2	17 7/8	14 1/2	17	30 1/8	22	1/2	19 1/2	184T
182	18 1/4	1 3/16	23 1/8	17	19 5/8	14 1/4	17 1/2	21 1/2	15	12 5/8	17 1/8	14 5/8	24 1/8	16	18 1/2	13 5/8	30 5/8	9 1/8	19 5/8	15 3/4	18 1/4	33 3/8	25	1/2	21 7/8	184T
200	20	1 3/16	25	17	21 1/2	15 7/8	17	23 3/8	16 1/2	13 3/4	18 3/4	15 3/4	26 3/8	17 5/8	20 3/8	14 7/8	31 1/2	10	21 1/2	17 7/8	20 1/8	36 1/4	25	1/2	23 3/4	213T
222	22 1/4	1 3/16	27 3/8	16 1/2	24	17 3/8	17	25 3/4	18 1/4	15 1/4	20 7/8	17 1/4	29	19 1/2	22 5/8	16 1/2	32 3/4	10 5/8	23 7/8	19 3/8	22 5/8	39 3/4	26	1/2	26 1/8	213T
245	24 1/2	1 7/16	30 1/4	16 1/2	26 1/4	19 1/4	16 3/4	23 5/8	20 1/8	16 7/8	23	19 7/8	32 1/2	21 1/2	24 7/8	18 1/4	33 5/8	11 3/4	26 3/8	21 1/4	24 1/2	42 7/8	26	1/2	27 3/4	215T
270	27	1 7/16	33	16 1/2	29	21 1/4	16 1/2	26 1/4	22 1/8	18 1/2	25 1/4	21 1/2	35 3/8	23 5/8	27 3/8	20	34 5/8	12 5/8	29	23 3/4	26 1/2	47	26	1/2	30 1/2	215T
300	30	1 11/16	36 1/4	16 1/2	32 1/4	23 3/8	16 1/2	29 1/2	24 5/8	20 1/2	28 1/8	23 5/8	39 3/8	26 3/8	30 1/2	22 1/2	36	13 3/4	32 1/4	26	28 3/4	51 7/8	27	1/2	33 3/4	254T
330	33	1 11/16	39 1/2	21 3/8	35 3/8	25 7/8	21 5/8	33 1/8	27 1/8	22 1/2	30 7/8	25 5/8	43	28 7/8	33 1/2	24 3/8	41 3/8	15	35 3/8	28 3/8	31 1/8	58 1/2	30 3/8	7/8	38 3/8	254T
365	36 1/2	1 5/16	43 1/8	21 3/8	39 1/4	28 1/2	21 5/8	36 7/8	30	24 7/8	34 1/8	28	47 3/8	32	37 1/8	27	43 1/4	16 1/4	39	31	33 3/4	63 3/4	30 3/8	7/8	42 1/8	254T

NOTE: Letters "C" and "D" are outside housing dimensions.
 *"C" dimension on 105 extends 1 1/16" beyond center-line.

TEMPERATURE OPERATING LIMITS TEMPERATURE RPM DERATING FACTORS IN PERCENT:	
STEEL WHEEL	ALUMINUM WHEEL
300°F 100%	150°F 100%
301-400°F 96%	151-200°F 95%
401-500°F 92%	201-250°F 80%
501-600°F 85%	

PEERLESS BLOWERS... Your Clean Air Source!

Supplier of Quality Products for Industry:

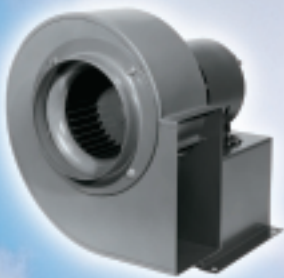

Direct Drive Fans

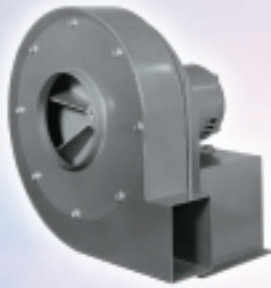

Pressure Blowers



Industrial Fans



Direct Drive Exhaust Fans



In-Line Centrifugal Fans



Backward Inclined Belt Drive Blowers



Belt Drive Propeller Fans



Powerfoil Fans



Plug-Pak Fans



Forward Curve Belt Drive Fans



PEERLESS BLOWERS

One Madison Avenue, P.O. Box 187
Hot Springs, NC 28743-0187
828/622-7500 • 1-800/613-4766 • Fax: 828/622-3309

www.peerlessblowers.com

E-Mail: sales@peerlessblowers.com



Registered to ISO 9001

CATALOG & BULLETIN INFORMATION

FOR

Aerator Media Scope of Supply

Type	Quantity	Layer Depth	Packaging
Polypropylene*	320 ft ³	60 in	10-ft ³ boxes

*Loose Fill media is field installed by others.

REV	REVISION DESCRIPTION	ECN	DESIGNER	APPROVER	DATE
THIS DRAWING IS PROPERTY OF WESTECH ENGINEERING, INC. AND IS TRANSMITTED IN CONFIDENCE. NEITHER RECEIPT NOR POSSESSION CONFERS OR TRANSFERS ANY RIGHTS TO REPRODUCE, USE, OR DISCLOSE IN WHOLE OR IN PART, DATA CONTAINED HEREIN FOR ANY PURPOSE WITHOUT THE WRITTEN PERMISSION OF WESTECH ENGINEERING, INC.					
DESIGNER	JO48	TITLE CATALOG & BULLETIN INFORMATION AERATION MEDIA SCOPE OF SUPPLY			
CHECKER	JO48	CLIENT WHITE RIVER WELL 3 VOC REMOVAL INDIANAPOLIS, INDIANA			
APPROVER	JO48				
DATE	08/23/2019				
FILE: 23925A-DS02-AERATION MEDIA SCOPE OF SUPPLY.docx		PROJECT 23925A	DOCUMENT NUMBER 23925A-DS02	SHEET 1 OF 1	REV -



LANPAC-XL[®]:
Advanced drip point technology



New, high efficiency tower packing combines extremely low pressure drop with excellent plugging resistance!

LANPAC-XL[®] new, advanced packing for use in:

- Air Strippers and Degasifiers
- High Efficiency Scrubbers
- Biological Treatment Systems

LANPAC-XL [®] Characteristics		
Dimensions	3.25" x 3.75"	83 x 95 mm
Effective surface area	74 ft ² /ft ³	242 m ² /m ³
Piece count	33 /ft ³	1165/m ³
Void fraction	95%	95%
Weight (polypropylene)	2.8 lb/ft ³	45 kg/m ³
Weight (PVDF)	5.5 lb/ft ³	88 kg/m ³
Packing factor	10/ft	33/m
Drip points	22,000/ft ³	776,600/m ³

- Advanced design increases gas/liquid contact surface
- Reduces capital costs for new towers
- Maximizes efficiency in shorter towers
- Reduces pressure drop through existing towers
- Allows for smaller, less expensive blowers
- Flow-through structure resists fouling
- Cuts maintenance costs and down time
- Reduces fan power consumption



LANPAC-XL[®] is NSF Certified

Lantec is the global leader in wet scrubbing and air stripping technology and has made countless technological advances for these applications.

Call Lantec for a free packed bed design!

Appendix B
Operations and Maintenance Plan

Installation, Operation and Maintenance Manual

Date: September 26, 2019

Revision: -

For:

White River Well 3 VOC Removal
Indianapolis, Indiana

Equipment:

One (1) Aluminum Forced Draft Aerator
96 Inches Square x 120 Inches Straight Side Height
Specification Section: 11500 – Aluminum Forced Draft Aerator
WesTech Model AWF310

WesTech Contact:

Project Manager: Ally Dennis
Phone: (515) 268.8467
Email: adennis@westech-inc.com

WesTech Job Number: 23925A

WESTECH

Copyright 2019

The contents of this manual are the confidential property of WesTech Engineering Inc. Circulation, distribution, or reproduction of this manual in whole or in part without written permission is prohibited by law. Possession of this manual neither confers nor transfers any rights, which may be detrimental to WesTech's interest.



For:

White River Well 3 VOC Removal
Indianapolis, Indiana

Equipment:

One (1) Aluminum Forced Draft Aerator
96 Inches Square x 120 Inches Straight Side Height
WesTech Model AWF310

Engineer:

American Structurepoint Inc.
7260 Shadeland Station
Indianapolis, Indiana 46256-3957
Contact: Michael David Mohler II, P.E.
Phone: (317) 547.5580
Email: -

Contractor:

Bowen Engineering Corporation
8802 North Meridian Street
Indianapolis, Indiana 46260
Contact: Kevin Canida, Project Manager
Phone: (317) 842.2616
Email: kcanida@bowenengineering.com

WesTech Agent:

B.L. Anderson, Inc.
4801 Tazer Drive / P.O. Box 2237
Lafayette, Indiana 47905
Contact: Rick Kocerha
Phone: (765) 463.1518
Email: rick@blanderson.com

Manufacturer:

WesTech Engineering, Inc.
600 Arrasmith Trail
Ames, Iowa 50010
Phone: (515) 268.8400
Fax: (515) 268.8500
24 Hour Emergency Assistance: (801) 265.1000

WesTech Contact:

Project Manager: Ally Dennis
Phone: (515) 268.8467
Email: adennis@westech-inc.com

WesTech Job Number: 23925A

This Page Intentionally Blank

Cover Page	
Title Page	
Table of Contents	
Product Line Cards	
Warning Summary	

Section One: Equipment Information.....	1-0
Warranty.....	1-1
One Year Warranty	1-3
General Precautions	1-4
Packing List.....	1-4
Equipment Tags.....	1-5
Receiving Material.....	1-5
Receiving Procedure.....	1-5
Handling and Storage.....	1-6
Surface Preparation	1-7
Fasteners.....	1-7
Foundation Anchor Bolts.....	1-7
Installation, Operation and Maintenance Manual.....	1-8
Shortages, Discrepancies and Field Changes	1-9
Structural Lifting Precautions	1-10
Lifting Recommendations	1-10
Pertinent Data.....	1-11
Section Two: Installation Instructions.....	2-0
Vendor Manuals	2-1
Aerator Installation – Forced Draft.....	2-3
Section Three: Start-up and Operation.....	3-0
Operation – Aerator.....	3-1
Section Four: Maintenance and Parts.....	4-0
Vendor Manuals	4-1
Maintenance: Forced Draft.....	4-3
Recommended Spare Parts.....	4-3
Recommended Maintenance.....	4-3
Section Five: Enclosures.....	5-0
Procedure for Ordering Spare or Replacement Parts.....	5-2
Section Six: Troubleshooting Guide	6-0
Section Seven: Mechanical.....	7-0
Mechanical Drawings	7-2
Mechanical Component Data Sheets.....	7-3

Drawing Number	Description
1-47949	Mechanical Aeration
23925A-DS01	Forced Draft Blower Scope of Supply
23925A-DS02	Aerator Media Scope of Supply

WesTech Corporate Services

Parts / Field Service / Training

- 24 Hour Hot-Line
- Full Service Parts Department
- Installation and Erection Services
- Mechanical Evaluations / Process Audits
- Operator Training
- Process Training
- Regional Service Technicians
- Service and Maintenance Agreements

Laboratory and Pilot Plant Testing

- Bench Scale Feasibility Testing
- Field Pilot Testing / Studies
- Plant Process Audits

Services

- Bench Scale Feasibility Testing
- Field Pilot Studies
- Installation and Erection Services
- Mechanical Evaluations
- Plant Process Audits

Pilot Rental Equipment

- AERALATER® - Aeration, Detention, and Filtration
- AltaFlo™ High Rate Thickener
- Buoyant Media Clarifier
- CONTRAFAST®- C
- CONTRAFAST®- E
- CONTRAFLO®
- Denitrification Filtration
- Dissolved Air Flotation
- Dual-Column Filtration
- Forced Draft Aerator
- High Rate Thickener
- Horizontal Belt Filter
- Inclined Plate Settler
- Linear Screen
- Microfiltration/Ultrafiltration
- Nanofiltration/Reverse Osmosis
- Paste Thickener
- Precoat Filter
- Pressure and Gravity Filter
- RapiSand™ Ballasted Flocculation solids CONTACT CLARIFIER™
- SuperSand™
- SuperDisc™
- Vacuum Drum Filter
- Trident®, Trident® HS

WesTech Municipal Water Products

Aeration

ATOMERATOR™
Cascade Aerator
Forced Draft Aerator
Induced Draft Aerator

Adsorption

Adsorption Clarifier®
Cation Exchange Softener
Granular Activated Carbon (GAC) Contactor

Covers

Zickert Retractable Membrane Cover

Electrical Controls

PLC Based Control System
UL Listed Panels (UL508A/UL698)

Flocculation

Horizontal Paddle Wheel Flocculator
Vertical Paddle Wheel Flocculator

Granular Media Filtration

ANTHRA/SAND™ Manganese Removal Media
CentROL® LP Cluster Filter
Circular and Rectangular Open Top Gravity Filter
ESSD™ Filter Trough
MULTIWASH® Filtration Process
MULTIBLOCK® Underdrain
MULTICRETE™ II Underdrain
Multi-Tech™ Multiple Barrier Filtration System
Horizontal Pressure Filter
Vertical Pressure Filter

Membrane Filtration

Microfiltration/ Ultrafiltration
Nanofiltration/Reverse Osmosis
VersaFilter™

Residuals Handling

Backwash Water Clarifier
Decanter Mechanism
Gravity Sludge Thickener
SuperSettler™ Inclined Plate Settler
Vacuum Drum Filter

Package Treatment Plants

AERALATER® Iron and Manganese Removal Plant
AltaPac™ Ultrafiltration Membrane System
Aquarius™ Conventional Package Plant
Tri-Mite™ Package Plant
Trident® Package Water Treatment System
Trident® HS Multi Barrier Package Plant
Water Boy™ Package Plant

Sedimentation/Clarification

Adsorption Clarifier®
Conventional Clarifier
CONTRAFLO® Solids Contact Clarifier
CONTRAFAST® High Rate Clarifier/Thickener
Flocculating Clarifier
RapiSand™ Ballasted Flocculation
Sludge Sucker™ Sludge Siphon Clarifier
solids CONTACT CLARIFIER™
SPIRACONE™ Clarifier
SuperSettler™ Inclined Plate Settler
Trident® HSC Multi-Barrier Clarifier
Zickert Shark™ Sludge Removal

Softening

Cation Exchange Softener
CONTRAFLO® Solids Contact Clarifier
CONTRAFAST® High Rate Clarifier/Thickener
solids CONTACT CLARIFIER™

Tankage

Anchor Channel Tank
Flat Bottom Tank
Elevated Tank

WesTech Municipal Wastewater Products

Anaerobic Digestion Equipment

- Cleanergy Biogas Generator
- Digester Cover - Radial Beam Style
- Digester Cover - Truss Style
- DuoSphere™ Dual-Membrane Gas Holder
Slab and Tank Mount
- Extreme Duty™ Mechanical Sludge Mixer
- Sludge Heating System

Biological Treatment

- BioDoc™ Rotary Distributor
- ClearLogic™ MBR System
- HydroDoc™ Rotary Distributor
- Landex™ Oxidation Ditch
- OxyStream™ Advanced Oxidation Ditch
Process
- Package Plants
- RSD1™ Rotary Distributor
- Slow Speed Surface Aerators
- STM-Aerotor™ IFAS Systems

Clarifiers

- C.O.P™ Clarifier Optimization Package
 - Spiral Blades
 - Sludge Ring
 - Dual Gate EDI
- Conventional Scraper Blade
- RapiSand™ Ballasted Flocculation
solids CONTACT CLARIFIER™
- Suction Header
- Suction Pipe
- Zickert Shark™

Combined Sewer Overflow

- ROMAG CSO Screens
- WWETCO FlexFilter™
- WWETCO FlexFlo™ Control Valve

Dissolved Air Flotation

- Algae Removal
- Pretreatment Clarifiers
- Rectangular & Circular
- Sludge Thickeners

Electrical Controls

- PLC Based Control Systems
- UL Listed Panels (UL508A/UL698)

Filters

- CentROL® LP Cluster Filter
- MULTIWASH® Filtration Process
- SuperSand™ Continuous Backwash Filter
- SuperDisc™ Cloth Media Disc Filter
- Trident® Package Plant
- WWETCO FlexFilter™

Headworks

- CleanFlo™ Rotoscreen® Fine Screen
- CleanFlo™ Monoscreen® Fine Screen
- CleanFlo™ ALL-IN-ONE (Complete Plant)
- CleanFlo™ Element Continuous Belt Screen
- CleanFlo™ MultiRake
- CleanFlo™ Shear (Internally Fed Rotary Drum
Screen)
- CleanFlo™ Spiral Screen (Inclined and Vertical)
- CleanWash™ Screw Wash and Counter Pressure
Screw
- CleanGrit™ Grit Washers
- Gritt Mitt™ Grit Classifiers
- Shaftles Spiral Conveyor and Compactor
- Vortex Grit Separators
- Zickert Shark™ Grit and Grease Removal

Membrane Filtration

- Microfiltration/Ultrafiltration
- Nanofiltration/Reverse Osmosis
- VersaFilter™

Rectangular Basin Skimming

- Helical Scum Skimmers
- Rotating Scum Pipes
- Zickert Skimmer

Replacement Drives

- Adaptable to All Other Manufacturers
- Clarifiers
- Grease Lubricated Option
- Precision Bearing
- Thickeners

Septage Receiving Station

- Customer Management / Billing Software
- Hauler Access Stations
- Screening and Grit Removal Options

Tankage

- Field Erection
- Material Supply

Thickeners

- Center Feed
- CleanFlo™ Rotary Drum Thickener
- DAF Thickening
- Rake Lifting Devices
- Side Feed

WesTech Industrial Water and Wastewater Products

Aeration

Cascade Aerator
Forced / Induced Draft Aerator

Barrier / Media Filtration

AERALATER® Iron / Manganese Removal
AltaPac™ Ultrafiltration Package Systems
Cation Exchange Softeners
Circular or Rectangular Gravity Filter
CentROL® LP Cluster Filter
GAC Contactors
Microfiltration/ Ultrafiltration
Multi-Tech™ Multiple Barrier Filtration System
MULTIWASH® Filtration Process
Nanofiltration/ Reverse Osmosis
Pressure Filter (Vertical or Horizontal)
Self Stored Backwash Filter
SuperDisc™ Cloth Media Disc Filter
SuperSand™ Continuous Backwash Filter
Tri-Mite™ and Trident® Package Treatment
Trident® HS Package Plant
VersaFilter™ Membrane Filtration
Water Boy™ and Aquarius™ Package Plant
WWETCO FlexFilter™

Biological Treatment

BioDoc®/ HydroDoc Rotary Distributor
Biotreater
Cleanergy Biogas Generator
ClearLogic MBR Systems
DuoSphere™ Dual Membrane Gasholder
Slab or Tank Mount
HydroDoc™ Rotary Distributor
Oxidation Ditches
Slow Speed Surface Aerators
STM Aerotor™ IFAS Systems
UASB – Upflow Anaerobic Sludge Blanket

Clarification / Sedimentation

Backwash Clarifier
Buoyant Media Clarifier
Conventional Clarifier
Cooling Tower Slip Stream Treatment
COP™ Clarifier
Draft Tube™ Clarifier
CONTRAFast® High Rate Clarifier/Thickener
Flocculating Clarifier
Metallurgical Contact Clarifier

Rapisand™ Ballasted Flocculation
Rim Drive Clarifiers
Scale Pit Scraper/Skimmer
Sludge Sucker
SPIRACONE™ Clarifier
solids CONTACT CLARIFIER™
Suction Header COP
Suction Pipe Clarifiers
SuperSettler™ Inclined Plate Settler
Traveling Bridge Clarifiers
Zickert Shark™ Sludge Removal

Clarifier / Thickener Drives

Bridge Supported Shaft Drive
Column Supported Cage Drive
PasteThick™ Drive
Replacement, Retrofit, and Rebuild Options
for All Manufacturers
Titan Traction™ Drive

Dewatering

Belt Press
Ceramic Disc Filter
Horizontal Vacuum Belt Filter
Precoat Drum Filter
Recessed Plate Filter Press
Rotary Vacuum Disc Filter
Rotary Drum Vacuum Filter
Tower Press

Dissolved Gas Flotation

Circular
Rectangular

Electrical Controls

PLC Based Control Systems
UL Listed Panels (UL508A / UL698)

Oil / Water Separation

DAF Units (Circular or Rectangular)
DNF Units (Circular or Rectangular)
Oil / Water Separator (Circular or Rectangular)
Scale Pit Skimmer/Scraper

Screens

CleanFlo™ Rotoscreen®
CleanFlo™ Monoscreen®
CleanFlo™ ALL-IN-ONE (Complete Plant)
CleanFlo™ Element Continuous Belt Screen

WESTECH

Phone: 801.265.1000
www.westech-inc.com

CleanFlo™ Shear (Internally Fed Drum Screen)
CleanFlo™ Spiral Screen (Inclined and Vertical)
CleanWash™ Screenings Washer / Compactor
Counter Pressure Screw
CleanGrit™ Grit Washers
Gritt Mitt™ Grit Classifiers
Vortex Grit Separators
Zickert Shark™ Grit and Grease Removal

Softening

Cation Exchange Softener
Cold Lime Softener
Warm Lime Softener

Tankage

Anchor Channel Tank
Elevated Tank
Steel Bottom Tank
Supply and / or Field Erection

Thickeners

AltaFlo™ High Rate Thickener
Conventional Thickener
Deep Bed™ Paste Thickener
HiDensity™ Paste Thickener
HiFlo™ High Rate Thickener
Swing Lift Thickener
Traction Drive Thickener
TOP™ Thickener Package

WesTech Industrial Mining and Metallurgical Products

Clarifiers

- Buoyant Media Clarifier
- Flocculating Clarifier
- Metallurgical Contact Clarifier
- RapiSand™ Ballasted Flocculation
- Solids CONTACT CLARIFIER™
- CONTRAFAST® High Rate Clarifier/Thickener
- SuperSettler™ Inclined Plate Settler

Heavy Duty Drives

- Bridge Supported Shaft Drive
- Column Supported Cage Drive
- PasteThick™ Drive
- Retrofit and Rebuild Options for All Manufacturers
- Titan Traction™ Drive

Granular Media Filtration

- CentROL® LP Cluster Filter
- Circular & Rectangular Gravity Filter
- MULTICELL® Horizontal Pressure Filter
- Multi-Tech™ Multiple Barrier Filtration System
- MULTIWASH® Filtration Process
- Self-Stored Backwash Filter
- SuperSand™ Continuous Backwash Filter
- Vertical Pressure Filter
- WWETCO FlexFilter™

Man Camp Potable Water Treatment

- AltaPac™ Ultrafiltration Package System
- Tri-Mite™ & Trident® Package Plant
- Water Boy™ & Aquarius™ Package Plant

Man Camp Wastewater Treatment

- BioTreater
- ClearLogic™ MBR System
- STM-Aerotator™ IFAS Package System

Membrane Filtration

- AltaPac™ Ultrafiltration Package System
- Microfiltration/ Ultrafiltration
- Nanofiltration/ Reverse Osmosis
- VersaFilter™

Screens

- CIP / CIL, RIP/RIC Media Retention Screen
- Linear Trash Screen
- Screw Classifiers

Tankage

- Anchor Channel Tank
- Elevated Tank
- Steel Bottom Tank
- Supply and / or Field Erection

Thickeners

- AltaFlo™ High Rate Thickener
- Conventional Thickener
- Deep Bed™ Paste Thickener
- HiDensity™ Paste Thickener
- HiFlo™ High Rate Thickener
- Swing Lift Thickener
- TOP™ Thickener Package

Dewatering

- Disc Filter
- Horizontal Belt Filter
- Precoat Drum Filter
- Rotary Drum Filter
- Belt Discharge
- Roll Discharge
- Scraper Discharge
- Tower Press

This Page Intentionally Blank

Warning Summary

WesTech recommends that this page be thoroughly read and understood before erecting and operating the equipment. The procedures must be followed as WesTech will not accept responsibility for damage to equipment that has not been handled in accordance with the manufacturer's instructions. A brief summary of the warnings are listed below.

Operating and maintaining this equipment has inherent risks. It is your responsibility to read and understand the Installation, Operation and Maintenance Manual prior to working with the equipment. This page is intended to summarize the warnings associated with WesTech's equipment. Where equipment manufactured by others has been provided in conjunction with WesTech equipment, additional warnings specific to that piece of equipment may only be contained in that section of the manual. Please read and understand all warnings provided in this manual.

Failure to observe warnings listed in this manual for WesTech Equipment or other manufacturer's equipment listed in the Operations and Maintenance Manual may void WesTech's Warranty.

Section One: Equipment Information

- No Warnings This Section

Section Two: Installation Instructions

Aerator Installation

- Some Aerators have lifting lugs positioned on the hinged and bolted door. A warning label should be stenciled on these units recognizing these lugs being for the door only. Do **not** lift the entire unit by these lifting lugs.

Section Three: Startup, Operation and Maintenance

- No Warnings This Section

Section Four: Electrical

Electrical

- Warning: Failure to follow instructions and safe electrical procedures could result in serious injury or fatality.
- Disconnect all power before servicing.
- Install and ground per local and national codes.
- Consult qualified personnel with questions or if repairs are required.

Troubleshooting

- Caution: Do not perform any maintenance or service on this motor before disconnecting the power source.
- Discharge all capacitors before servicing motor.
- Always keep hands and clothing away from moving parts.
- Never attempt to measure the temperature rise of a motor by touch. Temperature rise must be measured by thermometer, resistance, imbedded detector, or thermocouple.
- Electrical repairs should be performed by trained and qualified personnel only.

Failure to follow instructions and safe electrical procedures could result in serious injury.

Section One: Equipment Information

This Page Intentionally Blank

Warranty

This Page Intentionally Blank

One Year Warranty

WesTech equipment is backed by WesTech's reputation as a quality manufacturer, and by many years of experience in the design of reliable equipment.

Equipment manufactured or sold by WesTech Engineering, Inc., once paid for in full, is backed by the following warranty:

For the benefit of the original user, WesTech warrants all new equipment manufactured by WesTech Engineering, Inc. to be free from defects in material and workmanship, and will replace or repair, F.O.B. its factories or other location designated by it, any part or parts returned to it which WesTech's examination shall show to have failed under normal use and service by the original user within one (1) year following initial start-up, or eighteen (18) months from shipment to the purchaser, whichever occurs first.

Such repair or replacement shall be free of charge for all items except for those items such as resin, filter media and the like that are consumable and normally replaced during maintenance, with respect to which, repair or replacement shall be subject to a pro-rata charge based upon WesTech's estimate of the percentage of normal service life realized from the part. WesTech's obligation under this warranty is conditioned upon its receiving prompt notice of claimed defects, which shall in no event be later than thirty (30) days following expiration of the warranty period, and is limited to repair or replacement as aforesaid.

This warranty is expressly made by WesTech and accepted by purchaser in lieu of all other warranties, including warranties of merchantability and fitness for particular purpose, whether written, oral, express, implied, or statutory. WesTech neither assumes nor authorizes any other person to assume for it any other liability with respect to its equipment. WesTech shall not be liable for normal wear and tear, corrosion, or any contingent, incidental, or consequential damage or expense due to partial or complete inoperability of its equipment for any reason whatsoever.

This warranty shall not apply to equipment or parts thereof which have been altered or repaired outside of a WesTech factory, or damaged by improper installation, application, or maintenance, or subjected to misuse, abuse, neglect, accident, or incomplete adherence to all manufacturer's requirements, including, but not limited to, Operations & Maintenance Manual guidelines & procedures.

This warranty applies only to equipment made or sold by WesTech Engineering, Inc.

WesTech Engineering, Inc. makes no warranty with respect to parts, accessories, or components purchased by the customer from others. The warranties which apply to such items are those offered by their respective manufacturers.

General Precautions

The erection instructions enclosed are provided to assist in the assembly and adjustment of this mechanism. These procedures are not intended as a substitute for the experience of the persons assigned to erecting and assembling this equipment. WesTech strongly suggests that these instructions be studied prior to erecting, assembling, and adjusting.

During assembly of this equipment, it will be necessary to install, adjust, and maintain certain accessory items not manufactured by WesTech. This accessory equipment must be stored, handled, adjusted, and maintained in accordance with instructions provided by the manufacturer of that equipment. This is absolutely necessary in order to be assured of prompt and full participation in the warranty protection on the equipment. WesTech will not accept responsibility for damage to equipment that has not been handled in accordance with the manufacturer's instructions.

Packing List

The Contractor's packing list consists of a sheet containing an itemized listing of parts.

The packing list contains:

1. A description of the item.
2. Sizes and lengths of nuts and bolts. These fasteners will ship tagged with the item numbers.
3. The quantity of parts per assembled unit.
4. Total quantity of parts shipped.
5. An indication of direct shipment from the supplier or the fabricator.
6. The date and job number of the shipment.

The packing list will be found in one of the crates shipped directly from WesTech Engineering. The list should be kept in a readily accessible and safe place. Many contractors prefer to keep this list in some type of binder for protection and quick reference.

This list is particularly useful during erection for locating small parts and fasteners. When coordinated with the erection drawings, equipment tagging, and piece marking, the contractor's packing list can become an invaluable erection tool.

Equipment Tags

Each shipping piece has been tagged or piece marked for convenience. Typically, the part number and item number will be marked on all items. Piece marked items received will have a mark such as “Part No. D120A” or “Item 20” which may be cross-referenced with the packing list and general erection drawings.

Receiving Material

The equipment pieces and components received may have been shipped from:

1. WesTech Engineering, Inc.
2. A fabricator acting under WesTech Engineering, Inc. instructions.
3. A “buy-out” distributor such as a motor or pump manufacturer.

Since there will often be more than one shipment to the job site, it is important to coordinate the receiving and storage of all items accordingly. All material has been thoroughly checked and inspected before shipment. However, there may be times when equipment is missing, damaged in transit, or received with broken packaging. When receiving equipment, it is necessary to properly acknowledge receipt and any shortage or damage on the shipping documents. This must be done in a manner that helps assign responsibility to the proper party for the various parts of shipping and receiving equipment.

When receiving a shipment, the following procedures must be followed. These procedures are also listed on the Bill of Lading the shipping company provides and must be signed to prove delivery of the goods. If the following procedures are not followed, WesTech will not be liable for any shortages or damage on your shipments.

Receiving Procedure

1. Before signing the Bill of Lading (BOL) in receipt of the goods shown thereon, and before the driver leaves, do the following:
 - a. After inspecting the shipment, note any damage or shortages (according to what is listed on the BOL). Be as detailed as necessary.
 - b. Have the driver sign the notation in acknowledgment.

- c. Retain a copy (of the notated BOL) for use in filing a freight claim.
 - d. If there is damage, notify WesTech (801) 265.1000 immediately so that arrangements can be made with the carrier, if necessary, to have the damaged goods inspected by their agent.
2. After signing the BOL and receiving the shipment, do the following:
 - a. Use the attached/enclosed packing list to further inspect the entire shipment for shortages and/or damage, and retain this list for future reference.
 - b. Notify WesTech within three working days from date of receipt of any further shortages or concealed damage. If certain items are missing or damaged, make notes of this on the shipping papers to protect all interests and notify WesTech (801) 265.1000 immediately.

Handling and Storage

Please handle the equipment properly when unloading and erecting. All cartons, electrical equipment, and gear drives should be stored under cover and protected from moisture, grit, and mud. All rolled steel sections must be stored on edge or blocked up to prevent distortion. If allowed to lie flat, these items may lose their shape, which could hinder erection and proper alignment of the equipment.

Long structural shapes should be checked for the proper camber. This would include beams, trusses, walkways, etc. The equipment has been designed with a positive camber so items do not appear to be sagging after erection.

Surface Preparation

The material supplied for this job has received surface preparation in accordance with the specific contract plans and specifications.

Any indentations, marks, and/or scratches caused by loading and unloading the equipment must be immediately touched up in the field prior to storage.

Shop Primer Paint Durability

Shop primed surfaces should be finish coated within the time specified by the paint manufacturer. WesTech cannot be held responsible for shop-primed surfaces that have deteriorated due to time and exposure.

Fasteners

All stainless steel erection fasteners shall incorporate anti-seize during assembly. Failure to utilize this will cause significant extra time by the erection and maintenance crews.

Foundation Anchor Bolts

If required, WesTech Engineering ships anchor bolts direct to the job site upon receipt of the approved prints. Notify WesTech immediately if anchor bolts are not received as promised.

Anchor bolts must be placed accurately to avoid future erection difficulties. Where applicable and upon request, WesTech can furnish a template for positioning the anchor bolts. If a template has not been furnished, remember that the location and projection of all anchorage is critical. The specified amount of projection and location are shown on the general arrangement drawings. Prior to equipment installation, clean the threads of all anchorage bolts and oil them.

If using epoxy anchors, confirm the expiration date of the epoxy, typically posted on the packing, prior to mixing and application. WesTech will guarantee the effectiveness of the epoxy up to the aforementioned date. Installer is to adhere to epoxy installation procedures noted on packaging.

Installation, Operation and Maintenance Manual

Keep an Installation, Operation and Maintenance Manual in the area where the operators can familiarize themselves with it and have it for reference. The manual is useless if the operator and foreman do not have access to it.

Further Assistance

If a problem is encountered while installing or operating the equipment that cannot be solved by referring to this manual, feel free to contact

WesTech Engineering, Inc.

600 Arrasmith Trail

Ames, Iowa 50010

Phone: (515) 268.8400

Fax: (515) 268.8500

24 Hour Emergency Assistance: (801) 265.1000

Shortages, Discrepancies and Field Changes

Please notify WesTech Engineering, Inc. immediately if any apparent manufacturing discrepancies or shortages are encountered with machinery, since no field charges for alterations or shortages will be accepted unless authorized in writing by our authorized representative.

Fabricated steel parts and assemblies furnished by WesTech Engineering, Inc. are manufactured following best shop practices and standards. However, some misfits and imperfect work may arise. In such cases, the American Institute of Steel Construction Manual, Thirteenth Edition, "Code of Standard Practice" will apply to erection of this equipment. It reads as follows:

"7.14. Corrections and Errors

The correction of minor misfits by moderate amounts of reaming, grinding, welding or cutting, and the drawing of elements into line with drift pins, shall be considered normal erection operations. Errors that cannot be corrected using the foregoing means, or that require major changes in member or Connection configuration, shall be promptly reported to the Owner's Designated Representatives for Design and Construction and the Fabricator by the Erector, to enable the responsible entity to either correct the error or approve the most efficient and economical method of correction to be used by others."

Commentary:

"As used in this Section, the term "moderate" refers to the amount of reaming, grinding, welding or cutting that must be done on the project as a whole, not the amount that is required at an individual location. It is not intended to address limitations on the amount of material that is removed by reaming at an individual bolt hole, for example, which is limited by the bolt-hole size and tolerance requirements in the AISC and RCSC Specifications."

Company policy dictates that no field charges will be allowed without prior approval. Written authority must be given in the form of a WesTech Inspection and Change Work form with an attached warranty tracking number. The Warranty tracking number will be issued when the extent of such modifications and the price for performing these modifications have been agreed upon.

In general, when parts require replacement, and WesTech agrees that replacement is necessary, WesTech will furnish the parts. The contractor will remove the defective parts and install the replacement parts at a cost agreed upon by both parties.

Structural Lifting Precautions

Do not pull, drag, push or dump the structural components off the delivery trucks.

All structural components should be lifted and handled as instructed below. Proper handling is necessary to protect special coverings and to ensure ease of assembly during equipment installation.

WesTech will not accept charges for repair or replacement of equipment or materials damaged due to improper handling. Report any damage to WesTech, and make a notation on shipping papers to this effect.

Lifting Recommendations

Observe these precautions when lifting or handling structural components.

Stand clear as the equipment is lifted.

1. Make sure the equipment being lifted or the lifting equipment cannot come into contact with overhead electrical cables, etc.
2. Make sure the rigging and hoist equipment have adequate capacity. Weights for major components are listed on the Parts Lists in the Enclosures Section.
3. All rigging and lifting should be done by experienced personnel.
4. Before equipment is removed from delivery trucks, check to be sure the blocking, bracing and banding securing it to the carrier have been removed and it is ready for moving.
5. Use multiple point lifting whenever possible.
6. When lifting structural members of this equipment, such as rake arms, cages, walkways, etc., avoid twisting or bending the members. Use spreader beams, as necessary, to fully support the pieces as they are lifted.
7. Make sure shop provided camber is maintained when lifting rake arms and walkways.
8. Lift the equipment an inch or two off the trailer to be sure it is free to be moved and balanced correctly. Adjust as necessary.
9. Never move the equipment suddenly or in jerks, and never allow it to strike the ground, tank or other equipment.

Pertinent Data

Aerator

1. Type: Forced Draft Aerator
2. Application: Iron oxidation and reduction of dissolved gasses
3. Normal Capacity: 1,300 gpm
4. Nominal Size: 96" Width x 96" Length x 120" Height w/o legs
5. Housing Material: Aluminum w/two media installation/removal ports
6. Distributor Box: Aluminum with air stacks and target nozzles
7. Depth of Internals: 10 Feet
8. Type of Internal Fill: LANPAC-XL, size: 3 1/2"
9. Influent Pipe Size: 12" flanged
10. Effluent Pipe Size: 14" O.D. plain end pipe
11. Air Exhaust: Standard #24 mesh hood with moisture separator

Blower

1. Make: Peerless-Winsmith Inc.
2. Model: B-182 belt driven
3. Nominal Capacity: 4,800 CFM @ 3/8" Static Pressure
4. Motor: 2 hp, 480 Volts, 3 ph, 60 Hz, TEFC
5. Electrical Control: Motor starter is not by WesTech
6. Standard blower screened air inlet hood
7. Standard aluminum blower to Aerator transition
8. Remarks: Blower base is not by WesTech

This Page Intentionally Blank

Section Two: Installation Instructions

This Page Intentionally Blank

Vendor Manuals

WesTech supplied equipment may contain purchased components for which separate vendor supplied manuals have been provided (example: valves, drives, controls). The installation instructions within these manuals are not included within the WesTech installation portion of this manual. It is very important to reference these manuals for complete and proper installation of this equipment.

This Page Intentionally Blank

Aerator Installation – Forced Draft

1. Refer to the installation drawing included in this manual.
2. Lifting lugs have been provided at the four top corners of the Aerator. These can be used to lift the entire unit upright. On large units equipped with bottom stiffeners, the outer ends of the stiffeners have reinforced lifting holes that can be used to off-load the unit.
3. The Aerator has been assembled complete before shipment except for the following:
 - a. Forced Draft Blower
 - b. Blower Transition
 - c. Blower Inlet Hood
 - d. Air Exhaust Hood
 - e. Miscellaneous Hardware
 - f. Loose Fill Media
4. Remove the upper side port for installation of the loose fill media. Install at least half of the media while the Aerator is lying down. This will prevent media breakage that can happen if installed while vertical. The rest of the media can be installed while the Aerator is at a slight angle or vertical.
5. Mount Aerator as required per reference drawing and anchor legs. Each of the four legs is drilled 1" diameter to receive an anchor bolt. See installation drawing for recommended minimum size anchor. The Aerator base support should provide full support to the entire Aerator leg. (Anchor bolts are not normally furnished by WestTech Engineering, Inc.) It is recommended that the installing contractor provide an appropriate coating or product barrier for aluminum surfaces in contact with concrete or mortar to prevent corrosion.
6. Complete installation of Aerator as follows:
 - a. Mount the Air Exhaust Hood over the opening in the top of the Aerator and secure with the hardware provided. Space hardware on approximately 6" centers.
 - b. Connect the Blower Transition Hood to the side of the Aerator with the U-shaped transition channels. Secure at the corners with the hardware provided.
 - c. Mount the Forced Draft Blower in place on the base furnished by others and anchor as required.

Warning: Some Aerators have lifting lugs positioned on the hinged and bolted door. A warning label should be stenciled on these units recognizing these lugs being for the door only. Do **not** lift the entire unit by these lifting lugs.

Note: Make sure Aerator is level for proper operation. Normally if the base on which the unit is to be positioned is level within 1/8" in 10', no additional leveling under the legs is required. Check the Aerator pipe connections for proper elevation.

- d. Secure the Forced Draft Blower to the Blower Transition Hood Assembly with the hardware provided. Space hardware on approximately 6" centers.
- e. Secure the Blower Inlet Hood to the Forced Draft Blower intake flange with the hardware provided. Space hardware on approximately 6" centers.
7. Assemble the inlet piping to Aerator per Contract plans. The Aerator housing is not designed as a pipe support; therefore, inlet piping must be properly supported to prevent undue stress on the Aerator inlet pipe.
8. Connect the Aerator bottom outlet to the plant piping per Contract plans. The effluent piping must be properly supported to prevent undue stress on the Aerator outlet pipe. **Do not** suspend the effluent piping from the Aerator outlet pipe.
9. Wire blower motor for automatic start stop in conjunction with well or supply pump through a protective magnetic across the line starter furnished by others. See wiring diagram in this manual for details. Blower will be marked as to proper voltage required.

Check blower for proper rotation. The air flow should be through the blower and towards the Aerator. A simple test is to see if a piece of paper will cling to the inlet screen of the unit. If so, rotation is correct. If not, reverse the leads on the motor and try again.

Section Three: Start-up and Operation

This Page Intentionally Blank

Operation – Aerator

Forced Draft Aeration is an effective, inexpensive and low-maintenance method of improving finished water quality in a large number of applications. Generally used at the head of a water treatment plant facility, these units efficiently help remove unwanted water components and help stabilize the pH of corrosive waters for a large range of flows.

The Aerator introduces air and water for intimate contact in a counter-current flow to promote the oxidation of unwanted iron and manganese. Air is induced up through the Aerator chamber, while the water is introduced at the top of the unit to free-fall through the Aerator internals. The up flowing air sweeps through the falling water to increase the oxygen content of the water, removing unwanted dissolved gases such as carbon dioxide and hydrogen sulfide. Dissolved solids such as iron and manganese are transformed to their oxidized states, enabling them to be removed by downstream clarification and filtration equipment. In addition, the aeration process can remove objectionable taste and odors and reduce the chemical requirements on lime softening.

Incoming process water enters the top of the Aerator by the Influent pipe and is released to atmospheric pressure. The incoming water velocity or energy is absorbed by the Velocity Breaker to enhance the water distribution.

Water is then distributed by gravity across the area of the Aerator by the Distributor Box Target Nozzles within the Distributor Box. They provide a bell mouth water entrance to minimize plugging. The integral target provides for even water droplet distribution into the aeration section. Air Stacks within the Distributor Box ensure uniform distribution of the counter flow of air.

As the water droplets fall through a series of Loose Fill Media, they divide and reform repeatedly, exposing more surfaces to the air. A counter-current flow of air continuously sweeps upward through the droplets, absorbing and carrying away released gases and supplying oxygen for oxidation.

A Collector Pan area is furnished at the base of the housing to provide an area for incoming air to be distributed evenly over the bottom of the entire area of the unit. This area is used to collect the process water and direct it to the final Effluent pipe connection at the base of the unit.

Induced Draft Aerators utilize an axial flow Blower that is located on the top cover of the Aerator. This blower creates a negative pressure in the top portion of the Aerator Housing above the Distributor Box by drawing the air out of the unit. Air is then induced to flow into

Screened Air Inlet Hoods located on the lower side of the housing or Collector Pan Area.

Forced Draft Aerators utilize a non-overloading belt driven Blower located near the lower side of the housing or Collector Pan area of the Aerator. This blower creates a positive pressure in the lower portion of the Aerator Housing, thereby forcing the air to flow counter-current to the falling water. Air is then forced out of the Screened Air Exhaust Hood located on the top cover of the Aerator.

Section Four: Maintenance and Parts

This Page Intentionally Blank

Vendor Manuals

WesTech supplied equipment may contain purchased components for which separate vendor supplied manuals have been provided (example: valves, drives, controls). The maintenance instructions within these manuals are not included within the WesTech maintenance portion of this manual. It is very important to reference these manuals for complete and proper maintenance of this equipment.

This Page Intentionally Blank

Maintenance: Forced Draft

Recommended Spare Parts

None Recommended.

Examine the housing of the Aerator for integrity. Note any holes in the housing.

Most Forced Draft Aerators produced by WesTech are manufactured of low maintenance aluminum. The natural oxidized finish will weather to a light gray. This oxidation film provides the protective coating that prevents further corrosion. Removal of the surface oxidation is not recommended.

No customer stocked mechanical spare parts are required for WesTech Engineering, Inc. Forced Draft Aerators.

Most standard Forced Draft Blower component parts such as bearings, belts and motors are available through local motor and bearing suppliers or available from the factory.

The factory fabricated aluminum components such as air exhaust hoods and blower inlet hoods are available from our Parts Sales and will require a short lead time to allow for fabrication.

The Forced Draft Aerator internals are a combination of aluminum, plastic and stainless steel materials and should not need replacement under normal operating conditions.

Recommended Maintenance

Screens

A stiff bristled brush can be used to remove insect, leaf and other foreign particles from the screen surface. This is necessary to the operation or performance of the unit. The frequency of cleaning varies widely with each application and site conditions.

Housing: None

Most Induced Draft Aerators produced by WesTech Engineering, Inc. are manufactured of low maintenance aluminum. The natural oxidized exterior finish will weather to a light gray. This oxidation film provides the protective coating that prevents further corrosion. Removal of the surface oxidation is not recommended.

Blower

Observe the blower while running. The air should be pulled in at the blower intake hood and expelled at the top exhaust. Vibration and noise will be a good indication of the condition of the motor bearings and v-belt drive.

Shut off the electrical power to the Forced Draft Blower and remove the rain cover to inspect the v-belts and pulleys.

The Forced Draft Blower is normally provided in steel construction. The housing surfaces should be inspected for rust or paint deterioration. Remove any rust and recoat the housing with a high quality coating suitable for outdoor service.

Be sure to review and follow the Forced Draft Blower manufacturer's manual. This includes their recommendation for greasing the bearings.

Internals

Loose Fill: None

The loose fill typically used for gas exchange media is of a non-corrosive material and would only require replacement if fouled by high iron or carbonate waters.

It is generally good practice to inspect the Aerator loose fill at least yearly. If raw water changes and loose fill continues to foul with iron, consult WesTech Engineering, Inc. for recommended fill replacement materials.

Failure to correct media fouling will result in internal Aerator damage and increase loading to any external support structure.

Section Five: Enclosures

This Page Intentionally Blank

Procedure for Ordering Spare or Replacement Parts

Spare or replacement parts may be ordered from the Aftermarket Sales Department at:

WesTech Engineering, Inc.
3665 South West Temple
Salt Lake City, Utah 84115
Phone: (801) 265.1000
Fax: (801) 265.1080
24-hour service/emergency:
(801) 265.1000
Email: PARTS@westech-inc.com
Web: www.westech-inc.com

If you would like to talk directly to an Aftermarket Sales representative during normal business hours (8:00 am to 4:30 pm MST), dial (801) 265.1000 and ask for the Aftermarket Sales Department. You may fax your order to (801) 265.1080.

To use the 24-hour service/emergency line after hours (4:30 pm to 8:00 am), dial (801) 265.1000. Please indicate to the Answering Service Operator whether your facility is Water, Waste Water or Industrial. They will inform you that a WesTech Representative will call and assist you with your problem.

If you would like to e-mail a spare parts order, simply e-mail your request to us at PARTS@westech-inc.com, and a WesTech representative will process your order and follow up with an Order Acknowledgment.

Spare parts may also be requested directly from our web page www.westech-inc.com. Simply go to the web page, click on Parts & Service. If you know the part number and job information you need, you can input it directly. A WesTech Representative will process your request and follow up with a purchase quotation or a return phone call, to confirm that your request has been received.

For convenience, a 'Recommended Spare Parts List' is provided in this manual. This is a guide for the appropriate level of spares to keep on hand minimizing lost time due to unscheduled breakdowns. Each item listed in the Recommended Spare Parts List is identified within one of the following categories:

- Normal maintenance and wear items.
- Long Lead items (minimum downtime).

Should you require further assistance in determining which spare parts are appropriate for your particular situation please contact WesTech's Aftermarket Sales Department.

To avoid unnecessary delays in obtaining the correct spare or replacement parts for your equipment, be sure to give the following information with each order.

1. Identify equipment using the WesTech Job number. Your equipment is identified as follows:

WesTech Job Number: 23925A

WesTech Model Number: AWF310

2. Identify the part by name, and give the number of the drawing on which this part or assembly appears.
3. Identify the part number.
4. Identify the size and include all pertinent dimensions (such as diameter, length, thickness, bore, pitch, etc.) whenever possible.
5. If parts being ordered are electrical in nature, give all pertinent data such as voltage, amperage, wattage, cycles, speed, power factor, or other information given on the parts nameplate or included in the parts brochure.
6. Submit your written purchase order or request for a quotation, both signing and printing your full name so that WesTech will know whom to contact should further clarification of the inquiry be necessary. **All verbal orders must be verified in writing.**
7. Give a return address and a shipping address.
8. Give a preferred method of shipping: i.e., UPS, truck freight, rail freight, air express, etc.
9. Indicate the quantity desired.
10. Provide instructions for proper invoicing.
11. All spare or repair parts orders are subject to a \$100.00 minimum order charge.

Section Six: Troubleshooting Guide

This Page Intentionally Blank

Trouble Indication		Possible Cause	
A	Change in raw water	A1	Retest raw and finish water to ensure original tests were valid.
		A2	If multiple sources (wells) are used, return to original source (well).
		A3	Consult WesTech Engineering, Inc. if single source has changed to see if loading rate, air rate, or media could be designed to fit new conditions.
B	Change in water temperature	B1	Same as A3.
C	Change in raw water rate	C1	Return raw water supply to original design rate.
		C2	Same as A3.
D	Change in air rate	D1	Check blower for proper operation and rotation.
		D2	Clean air intake screens.
		D3	Fouled media. See E.
E	Fouled media	E1	Clean media.
		E2	Replace media.

Figure 6.1: Troubleshooting (Poor Efficiency/Effluent Quality)

Section Seven: Mechanical

This Page Intentionally Blank

Mechanical Drawings

Drawing Number	Description
1-47949	Mechanical Aeration

PROJECT COVER SHEET

PROCESS DESIGN INFORMATION		
DESIGN FLOW:	1,300	GPM
DESIGN WATER TEMPERATURE:	68	°F
DESIGN REMOVAL OF:	IRON AND DISSOLVED GASSES	

NOTES:

1. 1 UNIT TOTAL.
2. WORKS WITH DRAWING 1-47949.

PREPARED FOR	WHITE RIVER WELL 3 VOC REMOVAL INDIANAPOLIS, INDIANA
CUSTOMER	
ENGINEER	AMERICAN STRUCTUREPOINT INC. INDIANAPOLIS, INDIANA
CONTRACTOR	BOWEN ENGINEERING CORPORATION. INDIANAPOLIS, INDIANA
PO/CONTRACT NUMBER	1630256

**BACKCHARGES FOR FIELDWORK OF ANY KIND ARE NOT
ACCEPTABLE WITHOUT PRIOR WRITTEN AUTHORIZATION
BY WESTECH ENGINEERING, INC.**

REV	REVISION DESCRIPTION	ECN	DESIGNER	APPROVER	DATE



THIS DRAWING IS PROPERTY OF WESTECH ENGINEERING, INC. AND IS TRANSMITTED IN CONFIDENCE. NEITHER RECEIPT NOR POSSESSION CONFERS OR TRANSFERS ANY RIGHTS TO REPRODUCE, USE, OR DISCLOSE IN WHOLE OR IN PART, DATA CONTAINED HEREIN FOR ANY PURPOSE WITHOUT THE WRITTEN PERMISSION OF WESTECH ENGINEERING, INC.

TITLE	MECHANICAL AERATION FORCED DRAFT AERATOR 96IN SQ X 120IN HIGH, LF, 0.900, PE, 1600 GPM, 4800 CFM MAX				
DESIGNER	CHECKER	APPROVER	DATE		
PR63	JO48	JO48	2019 - 08 - 23		
DOCUMENT NUMBER			SHEET	REV	
23925A-1000			1 OF 1	-	

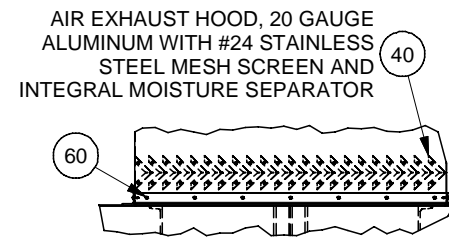

DETAIL C

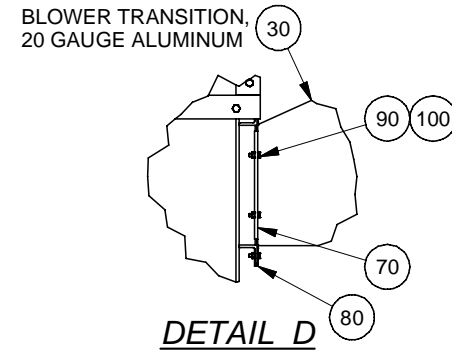

DETAIL D

BILL OF MATERIAL							
PIECE	UNIT QTY	PART NO	DESCRIPTION	MATERIAL	LENGTH	WIDTH	TOTAL WT, LB
10	1	1-47951	AERATOR ASSEMBLY, FORCED DRAFT, 96 SQ, 120 HIGH, LF, 0.900, PE				2799.2
20	1	2-29119	BLWR,HVAC;CENT;BELT DRIVE;#10 ARGT;182H;4800SCFM	STL			310.0
30	1	1-5574	TRANSITION, FD BLOWER, MODEL 182, 25 DEEP	3003-H14			10.0
40	1	1-10224	HOOD, EXHAUST FD, SCREENED 15 x 39				20.0
50	1	1-9150	HOOD, SCREENED, FD BLOWER INLET, MODEL 182				10.5
60	42	2-8857	SCREW, SHT METAL, PAN HD, PHILLIPS, NO 8 x 0.75	18-8			0.2
70	2	1-10249	CHANNEL, TRANSITION, DRILLED, 9	3003-H14			0.2
80	2	1-10258	CHANNEL, TRANSITION, DRILLED, 52.75	3003-H14			1.1
90	12	2-6320	CAP SCR, HEX, 0.25-20UNC x 0.75, FULL THREAD	304			0.2
100	12	2-5882	NUT, HEX, 0.25-20UNC	304			0.1
110	320	2-14356	MEDIA, LOOSE FILL, 3.25, CYLINDRICAL	PP			896.0
120	4	2-16476	ADHSV/SEALANT;PERMATEX	SILICONE			6.0

APPROX. TOTAL WEIGHT (LB)
4070.4

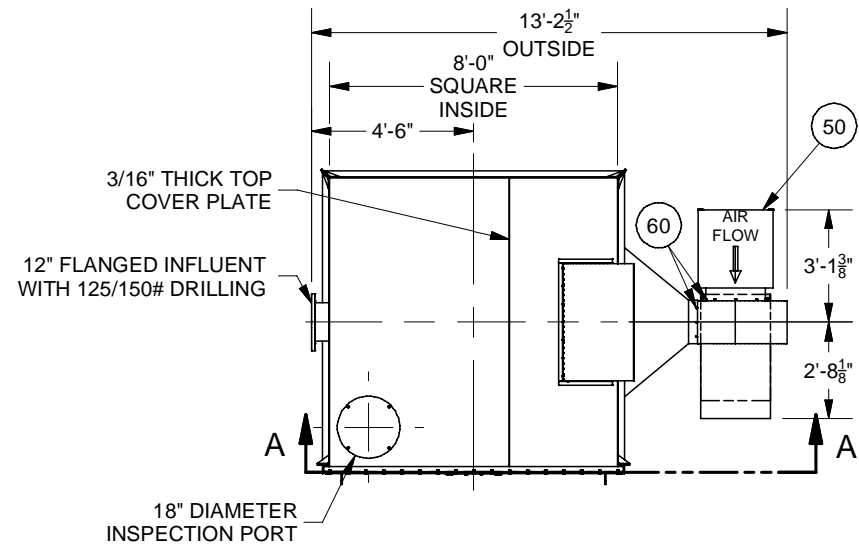

PLAN

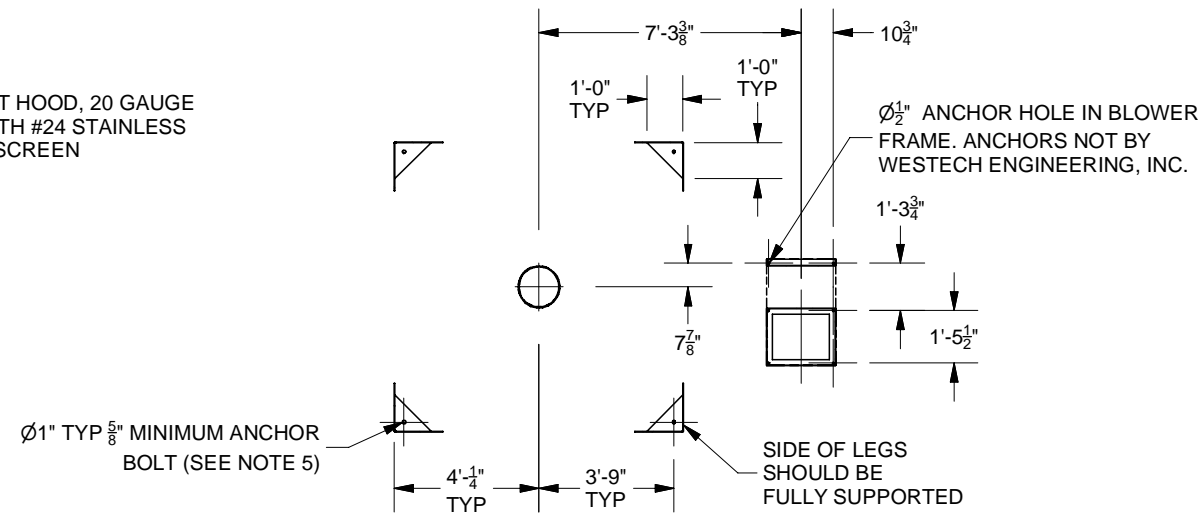

SECTION B-B

NOTES:

- 1.) AERATOR IS SHIPPED FULLY ASSEMBLED EXCEPT FOR SOME AIR HANDLING EQUIPMENT, HARDWARE, AND SEALANT. REFER TO BILL OF MATERIAL FOR IDENTIFICATION OF FIELD ASSEMBLED ITEMS.
- 2.) AERATOR SHIPS WITHOUT ALL PORT COVER HARDWARE INSTALLED TO AID IN MEDIA LOADING. REMAINING CAP SCREWS AND SEALANT FOR PORT COVERS ARE SHIPPED LOOSE.
- 3.) ALL AERATOR PLATE IS TO BE SERIES 3000 OR 5000 ALUMINUM. STRUCTURALS TO BE 6061 ALUMINUM.
- 4.) THE AERATOR SHALL BE WELDED INSIDE AND OUTSIDE WITH FILLET WELDS EQUAL TO THE THICKNESS OF THE PLATES. ALL MAIN HOUSING SEAM WELDS SHALL BE DYE PENETRANT CHECKED AT THE FACTORY BEFORE SHIPMENT TO ENSURE THEY ARE WATERTIGHT.
- 5.) THE MAXIMUM ANCHOR BOLT DIAMETER IS 7/8". THE MINIMUM WASHER DIAMETER IS 2" FOR ALL ANCHOR SIZES. ANCHORAGE IS BY OTHERS.
- 6.) FLANGE BOLT HOLE PATTERN IS TO STRADDLE UNIT CENTERLINE.
- 7.) AERATOR INLET AND EFFLUENT PIPE STUBS ARE NOT DESIGNED TO SUPPORT INLET AND EFFLUENT PIPING. ADDITIONAL PIPE SUPPORTS SHOULD BE USED BUT WILL BE SUPPLIED BY OTHERS.
- 8.) INFLUENT AND EFFLUENT PIPE MOUNTING HARDWARE AND GASKETS ARE PROVIDED BY OTHERS.
- 9.) IF INSTALLATION INSTRUCTIONS ARE NOT CLEARLY UNDERSTOOD, CONSULT WESTECH ENGINEERING, INC. FOR ADDITIONAL INFORMATION BEFORE COMMENCING ERECTION.
- 10.) IMPROPER STORAGE, HANDLING, INSTALLATION, OR FIELD MODIFICATIONS OF EQUIPMENT MAY RESULT IN DAMAGE AND LOSS OF WARRANTY PROTECTION.
- 11.) THE BLOWER MOTOR MUST BE WIRED CORRECTLY TO THE VOLTAGE LISTED ON THE UNIT.
- 12.) PLACE 3/8" BEAD OF BLUE PERMATEX SEALANT ON PORT COVERS INSIDE OF BOLT PATTERN BEFORE INSTALLING BOLTS.
- 13.) AERATOR MEDIA SHIPPED LOOSE FOR FIELD INSTALLATION.

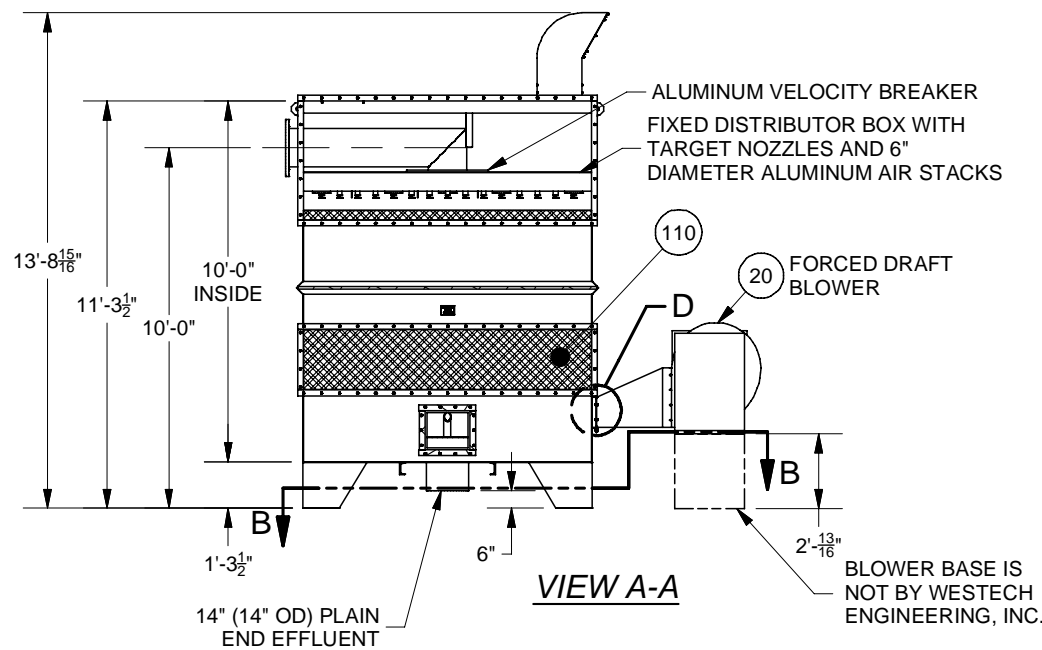

VIEW A-A

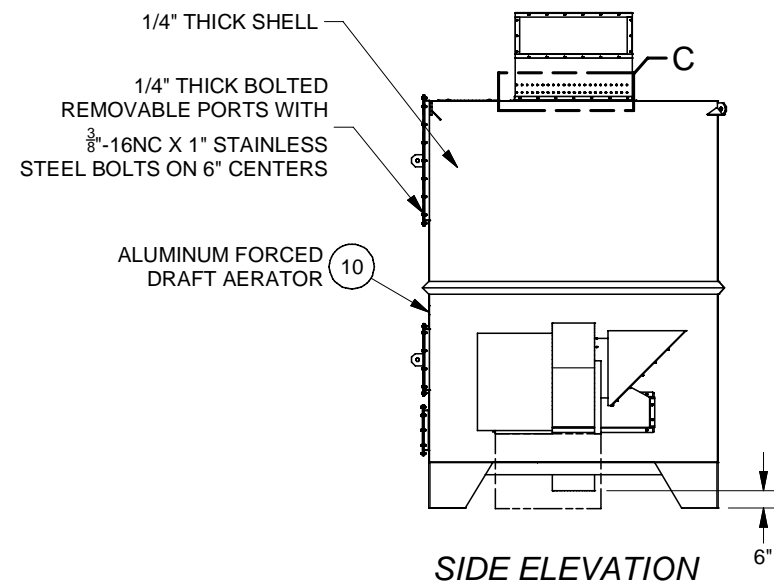

SIDE ELEVATION

REV	REVISION DESCRIPTION	ECN	DESIGNER	APPROVER	DATE

Westech			
THIS DRAWING IS PROPERTY OF WESTECH ENGINEERING, INC. AND IS TRANSMITTED IN CONFIDENCE. NEITHER RECEIPT NOR POSSESSION CONFERS OR TRANSFERS ANY RIGHTS TO REPRODUCE, USE, OR DISCLOSE, IN WHOLE OR IN PART, DATA CONTAINED HEREIN FOR ANY PURPOSE, WITHOUT THE WRITTEN PERMISSION OF WESTECH ENGINEERING, INC.			
TITLE MECHANICAL AERATION			
FORCED DRAFT AERATOR			
96IN SQ X 120IN HIGH, LF, 0.900, PE, 1600 GPM, 4800 CFM MAX			
DESIGNER	CHECKER	APPROVER	DATE
PR63	JO48	JO48	8/21/2019
DOCUMENT NUMBER			SHEET
1-47949			1 OF 1
REFERENCE DOCUMENTS			REV
			-

Mechanical Component Data Sheets

Drawing Number	Description
23925A-DS01	Forced Draft Blower Scope of Supply
23925A-DS02	Aerator Media Scope of Supply

CATALOG & BULLETIN INFORMATION

FOR

Forced Draft Blower Scope of Supply

Quantity	Volume	Pressure	Model	Motor
1	4,800 scfm	3/8 in SP	B182	2 hp, 480 V, 60 Hz, 3 ph, TEFC
Feature	Notes			
Housing	Reinforced heavy steel blower housing with weatherproof motor hood (Anchor bolts are not by WesTech.)			
Blower Wheel	Dynamically balanced welded steel			
Bearings	Anti-friction, self-aligning, grease packed, pillow block type with grease and dirt seal			
Drive	Adjustable V-belt			
Paint	Manufacturer's standard factory primed			

Note: Blower motor starters are not part of WesTech Aeration Equipment supply.

REV	REVISION DESCRIPTION	ECN	DESIGNER	APPROVER	DATE
THIS DRAWING IS PROPERTY OF WESTECH ENGINEERING, INC. AND IS TRANSMITTED IN CONFIDENCE. NEITHER RECEIPT NOR POSSESSION CONFERS OR TRANSFERS ANY RIGHTS TO REPRODUCE, USE, OR DISCLOSE IN WHOLE OR IN PART, DATA CONTAINED HEREIN FOR ANY PURPOSE WITHOUT THE WRITTEN PERMISSION OF WESTECH ENGINEERING, INC.					
DESIGNER	JO48	TITLE CATALOG & BULLETIN INFORMATION FORCED DRAFT BLOWER SCOPE OF SUPPLY CLIENT WHITE RIVER WELL 3 VOC REMOVAL INDIANAPOLIS, INDIANA			
CHECKER	JO48				
APPROVER	JO48				
DATE	08/23/2019				
FILE: 23925A-DS01-FORCED DRAFT BLOWER SCOPE OF SUPPLY.docx		PROJECT 23925A	DOCUMENT NUMBER 23925A-DS01	SHEET 1 OF 1	REV -

**PEERLESS
BLOWERS**

Ultrafan-Pak 2000

**Non-Overloading Belt Drive
Arrangement 10**

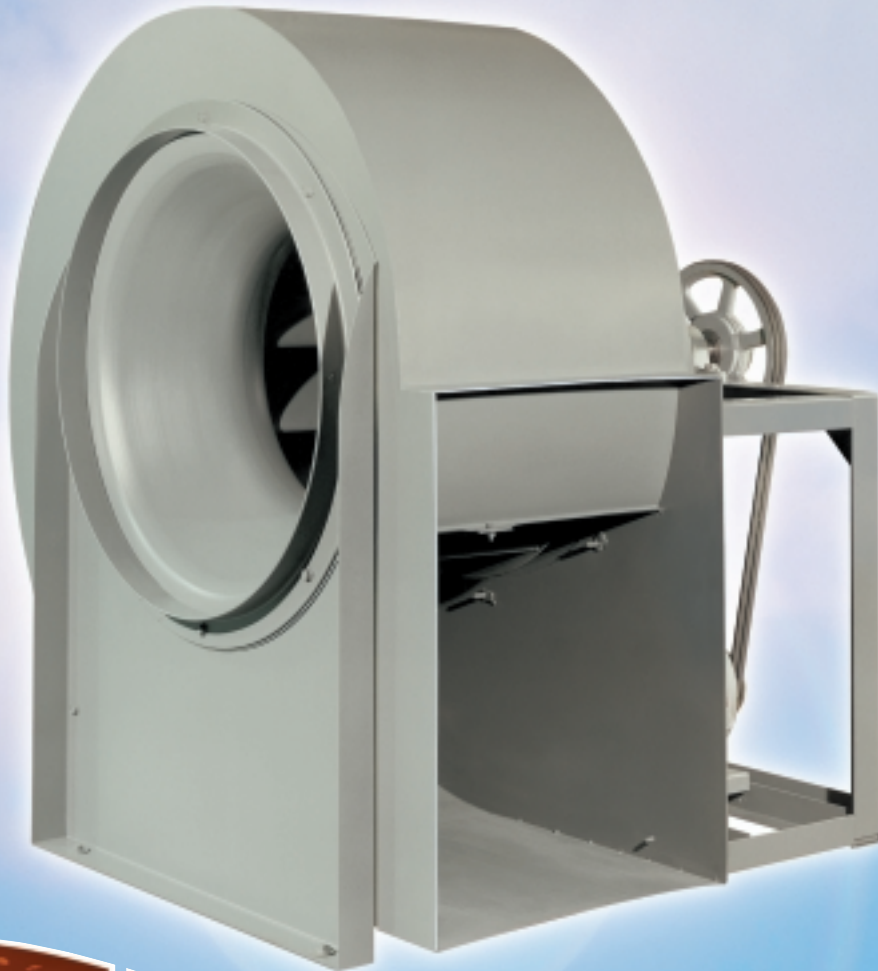

Your Clean Air Source!

PEERLESS BLOWERS

PEERLESS BLOWERS ULTRAFAN-PAK 2000 HIGH QUALITY... HIGH EFFICIENCY... VERSATILITY

PEERLESS BLOWERS ULTRAFAN-PAK 2000 INDEX

Peerless Blowers Ultrafan-Pak 2000	2
Ultrafan-Pak 2000 Construction Features	2
Material Specifications Class 1 and Class 2	3
Heavy Duty Anti-Friction Bearings	3
Ultrafan-Pak 2000 Accessories	4
Spark-Resistant Standards	4
Peerless Blowers Ultrafan-Pak 2000 Performance Tables	
B-105	5
B-122	6
B-135	7
B-150	8
B-165	9
B-182	10
B-200	11
B-222	12
B-245	13
B-270	14
B-300	15
B-330	16
B-365	17
Peerless Blowers Ultrafan-Pak 2000 Arrangement #10 Class 1	18
Peerless Blowers Ultrafan-Pak 2000 Arrangement #10 Class 2	19

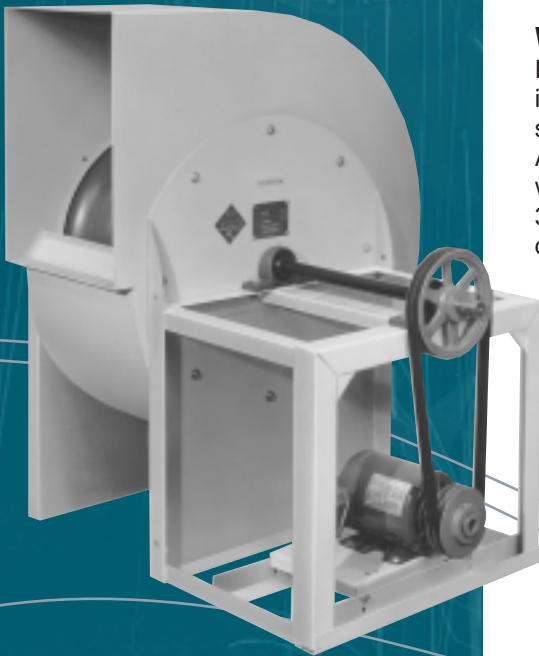

Established in 1893, **Peerless Blowers** has a well established record of manufacturing a complete line of heavy-duty industrial fans and blowers, as well as propeller fans for commercial and industrial applications. For over a hundred years, thousands of customers have come to know and depend on the quality-built, reliable and efficient fans and blower products produced by **Peerless Blowers**.

Our engineering and design departments are experts assisting customers develop custom-designed air conveying systems that will meet and exceed their critical fan or blower application requirements.

Fans and blower products manufactured by **Peerless Blowers** have and continue to provide exceptional performance, cost-efficient operation and long-term service to customers in numerous OEM,

commercial and industrial markets, including:

- Aviation • Automotive • Chemical
- Clothing • Food • Foundries
- Graphics/Printing • HVAC • Leather
- Maintenance • Manufacturing
- Mining • Paint • Paper/Pulp
- Petroleum • Plastics • Rail • Rubber
- Steel • Textile • And More!

Fans and blowers produced by **Peerless Blowers** have been application engineered and designed to meet and exceed all the requirements of today's air moving needs. Tested/rated to meet AMCA/ASHRAE Codes, our blowers are designed to provide maximum performance, long-term service and cost efficient operation in a wide variety of applications and environments.

Regardless of your air movement requirements, Peerless Blowers ...IS YOUR CLEAN AIR SOURCE!

ULTRAFAN-PAK 2000 BLOWER CONSTRUCTION FEATURES

Wheels

Flat Blade Wheel — backwardly inclined non-overloading wheels standard on sizes 105 thru 245.
Airfoil Wheel — backward curved airfoil wheels standard on sizes 270 thru 365. All wheels are statically and dynamically balanced.

Inlet

Circular stamped ring. Rigid streamlined inlet.

Frame

All welded steel construction. Easy access to motor for servicing.

Housing

All are convertible and may be rotated easily to any of eight 45° positions.

Motor Base

Heavy construction assures sturdy base for motor mounting and features easy adjustment for belt tension.

Bearings

Self-aligning ball bearing pillow blocks. These bearings are designed to operate under the most severe atmospheric conditions.

Shaft

Ground and polished solid steel key-wayed on each end.

Motor

Commercial standard Fan and Blower duty motors are job-matched to each requirement. All types of current characteristics, enclosures and bearing construction are available.

Adjustable V-Belt Drive

High quality CAST Iron adjustable pitch motor sheaves are standard equipment. V-Belts with ample service factor are also employed. When performance data is specified, the blowers are factory set to exact blower speed to meet job requirements. Constant speed drives are also available.

MATERIAL SPECIFICATIONS CLASS 1 AND CLASS 2

FAN SIZE	WHEEL DIAMETER	SHAFT DIAMETER		HOUSING GAUGES		NO. OF BLADES	WHEEL GAUGES				FRAME GAUGES	
		CLASS 1	CLASS 2	BAND	FACE		BLADES			END RING	DRIVE	INLET
							BACK PLATE	CLASS 1	CLASS 2			
105	10 ¹ / ₂	3/4	1	20	16	12	10	12	10	14	16	—
122	12 ¹ / ₄	1	1 ³ / ₁₆	16	16	12	3/16	12	3/16	14	14	16
135	13 ¹ / ₂	1	1 ³ / ₁₆	16	14	12	3/16	12	3/16	14	14	16
150	15	1	3/16	16	14	12	3/16	12	3/16	14	14	16
165	16 ¹ / ₂	1	1 ³ / ₁₆	16	14	12	3/16	10	3/16	14	14	16
182	18 ¹ / ₄	1 ³ / ₁₆	1 ³ / ₁₆	16	14	12	3/16	10	3/16	14	14	14
200	20	1 ³ / ₁₆	1 ⁷ / ₁₆	14	14	12	3/16	3/16	3/16	14	12	14
222	22 ¹ / ₄	1 ³ / ₁₆	1 ¹¹ / ₁₆	14	12	12	3/16	3/16	10	14	12	14
245	24 ¹ / ₂	1 ⁷ / ₁₆	1 ¹¹ / ₁₆	14	12	12	3/16	3/16	10	14	12	12
270	27	1 ⁷ / ₁₆	1 ¹¹ / ₁₆	14	12	11	3/16	16	16	14	12	12
300	30	1 ¹¹ / ₁₆	1 ¹⁵ / ₁₆	14	12	11	3/16	16	16	14	12	12
330	33	1 ¹¹ / ₁₆	1 ¹⁵ / ₁₆	14	12	11	1/4	16	16	14	10	10
365	36 ¹ / ₂	1 ¹⁵ / ₁₆	2 ³ / ₁₆	12	10	11	1/4	16	16	14	10	10

HEAVY DUTY ANTI-FRICTION BEARINGS

ULTRAFAN-PAK 2000 Blowers are equipped with self-aligning single row ball bearings.

Computerized selections have been made on all bearings based on radial, thrust and combined loads to give 100,000 average life hours (AFMBA L₅₀) on standard units at the maximum design of each blower.

Bearings selected have effective seals to retain the lubricant and to prevent against contamination. All have grease fittings for relubrication. Bearings are available for 400,000 Hours (AFMBA L₅₀).

The table at right shows the type bearings used for each unit.

Peerless Blowers reserves the right to change bearings of equal ratings.



FAN SIZE	STANDARD 100,000 HOURS	SPECIAL 400,000 HOURS
105	A	A
122	A	B
135	A	B
150	A	C
165	A	C
182	A	C
200	A	C
222	A	C
245	A	C
270	A	C
300	A	C
330	A	C
365	A	C

PEERLESS BLOWERS ULTRAFAN-PAK 2000

Peerless Blowers are built with these features:

Class 1 performance cataloged to 5" WG static pressure. Class 2 performance cataloged to 8.5" WG static pressure. Air delivery ranges from 509 CFM to 32,172 CFM.

Non-overloading performance — the backwardly inclined blade wheel gives a brake horsepower that levels off at a point to allow economical selection of motors that will not overload if

system pressure drops. The top four sizes have airfoil blades.

Easy installation and maintenance — the self-contained, completely packaged units allow easy access to motor, drive and bearings for ease in installation, lubrication, belt adjustment and wiring.

Rugged construction—heavy gauge all-welded steel construction. Discharge position on all sizes may be rotated to any of eight 45° positions.

CERTIFIED PERFORMANCE RATINGS

Peerless Blowers certifies that the "ULTRAFAN-PAK 2000" Blowers shown herein are licensed to bear the AMCA Seal. The ratings shown are based on tests and procedures performed in accordance with AMCA Publication 211 and comply with the requirements of the AMCA Certified Ratings Program.



PEERLESS BLOWERS ULTRAFAN-PAK 2000 ACCESSORIES

1. Weather Cover

Covers entire drive side frame and motor. Eliminates need for penthouse or other protection outdoors. Fastens securely with screws.



Drive Cover

2. Belt Guard

Covers the drives and entire frame end. Constructed of heavy gauge expanded metal mesh with welded steel frame.

Securely fastened with screws to blower frame.

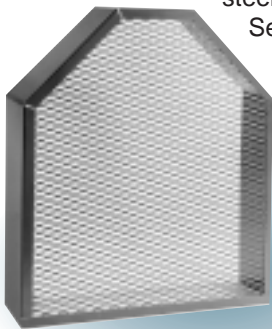

Belt Guard

3. Automatic Discharge Shutter

Self-contained in adapter sleeve and securely attached to fan discharge. All materials resistant to weather corrosion. Constructed to prevent backdrafts and entrance of rain and snow.

Discharge screens are not available with shutters.



Shutter

4. Clean-Out Doors

Bolted Door—Removable door for ease of cleaning and inspection. Bolted to housing with hex head bolts and gasketed for tight seal.

Quick-Opening Door—Held in Place with pressure latches, hinged at the bottom and gasketed.

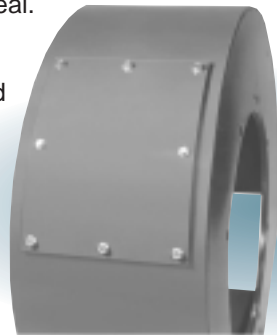

Bolted Door



Quick-Opening Door

5. Vibration Rail Bases

Shock mounting rubber-in-shear rails or pads and spring rails or pads are available as stock items.

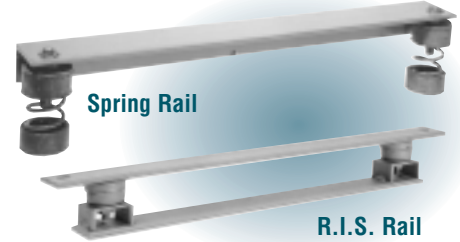

Spring Rail

R.I.S. Rail

6. Other Accessories

All size blowers are available with extra features such as: inlet vanes, drain fittings, inlet or discharge screens, flanged inlets or outlets, and heat slingers. Protective coatings are also available. Also available in spark resistant construction.

Sample specifications for ULTRAFAN PAK 2000 Backward Inclined Units

- Fan shall be single width, single inlet with backward inclined flat blade wheel on size: 105 through 245.
- Airfoil wheel on size: 270 through 365.
- CW or CCW rotation as specified.
- The fan shall be of welded and bolted, heavy gauge steel construction coated with Peerless Blowers' electrostatically applied baked polyester coating. The

housing shall be easily rotated to any of eight standard positions.

- The fan shall have self-aligning ball bearings and the shaft shall be ground and polished solid steel keywayed. The fan shall have a heavy duty, ball bearing motor matched to the fan load and furnished at the specified voltage, phase and enclosure.
- The fan shall have a drive with a cast iron adjustable pitch motor

sheave. The belts shall be oil and heat resistant.

- Fan to be arrangement 10, Class I or Class II construction (as required).
- All fans to be manufactured in an ISO 9001 Certified Facility.
- All fans shall bear the AMCA seal for air performance.
- Fan to be model "B" as manufactured by Peerless Blowers (Hot Springs, NC).

PEERLESS BLOWERS ULTRAFAN-PAK 2000 PERFORMANCE TABLES

B-182

TIP SPEED (FPM) = 4.778 x RPM

OUTLET { 1.899 Sq. Ft. Inside
19 5/8" x 14 1/4" Outside

MAX. HP = .6444 $\left(\frac{\text{RPM}}{1000}\right)^3$

WHEEL DIAMETER—18 1/4"

INLET { 2.02 Sq. Ft. Inside
19 5/8" Dia. Outside

MAX. RPM
CL.1 2044
CL.2 2666

VOL. CFM	OUTLET VEL. FPM	.25 S.P.		.5 S.P.		.75 S.P.		1 S.P.		1.25 S.P.		1.5 S.P.		2 S.P.		2.5 S.P.		3 S.P.		3.5 S.P.	
		RPM	BHP	RPM	BHP	RPM	BHP	RPM	BHP	RPM	BHP	RPM	BHP	RPM	BHP	RPM	BHP	RPM	BHP	RPM	BHP
1519	800	527	0.09	658	0.17	—	—	—	—	—	—	—	—	—	—	—	—	—	—	—	—
1709	900	562	0.11	679	0.19	793	0.28	—	—	—	—	—	—	—	—	—	—	—	—	—	—
1899	1000	599	0.14	705	0.22	809	0.31	911	0.42	—	—	—	—	—	—	—	—	—	—	—	—
2089	1100	638	0.16	736	0.25	831	0.35	925	0.46	1016	0.59	—	—	—	—	—	—	—	—	—	—
2279	1200	677	0.19	769	0.29	857	0.39	944	0.50	1029	0.63	1113	0.77	—	—	—	—	—	—	—	—
2469	1300	718	0.23	805	0.33	886	0.44	967	0.55	1047	0.68	1125	0.82	—	—	—	—	—	—	—	—
2659	1400	759	0.27	842	0.38	918	0.49	993	0.61	1068	0.74	1142	0.88	1286	1.19	—	—	—	—	—	—
2849	1500	801	0.31	880	0.43	952	0.55	1023	0.67	1093	0.81	1163	0.95	1299	1.26	1432	1.62	—	—	—	—
3038	1600	844	0.36	919	0.49	988	0.62	1055	0.74	1121	0.88	1186	1.02	1316	1.34	1442	1.70	—	—	—	—
3228	1700	888	0.42	959	0.55	1026	0.69	1089	0.82	1151	0.96	1213	1.11	1335	1.43	1456	1.79	1574	2.18	—	—
3418	1800	933	0.48	1000	0.62	1064	0.76	1124	0.91	1183	1.05	1242	1.20	1358	1.53	1473	1.89	1586	2.28	1697	2.70
3608	1900	978	0.55	1040	0.69	1103	0.85	1161	1.00	1217	1.15	1273	1.30	1383	1.63	1493	2.00	1601	2.39	1707	2.82
3798	2000	1023	0.63	1082	0.77	1142	0.94	1198	1.09	1252	1.25	1305	1.41	1411	1.75	1515	2.12	1619	2.52	1721	2.94
3988	2100	1068	0.71	1124	0.86	1182	1.03	1237	1.20	1289	1.36	1340	1.53	1440	1.88	1540	2.25	1639	2.65	1738	3.08
4178	2200	1114	0.80	1167	0.96	1222	1.13	1275	1.31	1326	1.49	1375	1.66	1471	2.01	1567	2.39	1662	2.80	1756	3.23
4368	2300	1159	0.90	1210	1.06	1263	1.24	1315	1.43	1364	1.61	1411	1.79	1504	2.16	1596	2.54	1687	2.95	1778	3.39
4558	2400	1204	1.01	1254	1.18	1305	1.36	1355	1.56	1403	1.75	1449	1.94	1538	2.32	1626	2.71	1714	3.12	1801	3.57
4937	2600	1296	1.25	1344	1.44	1389	1.62	1436	1.83	1481	2.04	1525	2.25	1609	2.66	1691	3.07	1772	3.50	1853	3.95
5317	2800	1388	1.53	1434	1.74	1475	1.93	1518	2.14	1562	2.37	1604	2.60	1684	3.04	1761	3.48	1837	3.93	1912	4.39
5697	3000	1481	1.85	1525	2.07	1563	2.28	1603	2.49	1643	2.73	1684	2.98	1760	3.46	1834	3.93	1905	4.40	1976	4.89
6077	3200	1573	2.20	1615	2.45	1653	2.67	1689	2.90	1727	3.14	1765	3.40	1839	3.92	1909	4.42	1977	4.93	2044	5.43
6457	3400	1669	2.63	1706	2.87	1743	3.12	1777	3.35	1811	3.60	1847	3.86	1918	4.41	1986	4.96	2051	5.50	2115	6.03

VOL. CFM	OUTLET VEL. FPM	4 S.P.		4.5 S.P.		5 S.P.		5.5 S.P.		6 S.P.		6.5 S.P.		7 S.P.		7.5 S.P.		8 S.P.		8.5 S.P.	
		RPM	BHP	RPM	BHP	RPM	BHP	RPM	BHP	RPM	BHP	RPM	BHP	RPM	BHP	RPM	BHP	RPM	BHP	RPM	BHP
3988	2100	1834	3.54	1930	4.03	2023	4.54	—	—	—	—	—	—	—	—	—	—	—	—	—	—
4178	2200	1850	3.69	1942	4.18	2033	4.69	2122	5.23	—	—	—	—	—	—	—	—	—	—	—	—
4368	2300	1868	3.86	1957	4.35	2044	4.86	2131	5.40	2216	5.97	—	—	—	—	—	—	—	—	—	—
4558	2400	1888	4.04	1974	4.53	2059	5.04	2143	5.58	2226	6.15	2307	6.74	—	—	—	—	—	—	—	—
4937	2600	1934	4.43	2014	4.93	2094	5.45	2172	6.00	2251	6.57	2328	7.15	2405	7.77	2480	8.40	—	—	—	—
5317	2800	1987	4.88	2062	5.39	2136	5.92	2211	6.47	2284	7.04	2357	7.64	2430	8.25	2502	8.89	2573	9.54	2643	10.22
5697	3000	2046	5.38	2116	5.90	2186	6.44	2256	7.00	2325	7.58	2394	8.19	2463	8.81	2531	9.44	2599	10.10	2666	10.78
6077	3200	2110	5.95	2176	6.48	2241	7.03	2307	7.60	2372	8.19	2438	8.80	2503	9.42	2567	10.07	2631	10.73	—	—
6457	3400	2177	6.57	2240	7.12	2302	7.68	2364	8.26	2425	8.86	2487	9.48	2548	10.11	2610	10.77	—	—	—	—
6836	3600	2248	7.24	2307	7.81	2366	8.39	2425	8.99	2483	9.60	2542	10.23	2600	10.87	2658	11.53	—	—	—	—
7216	3800	2321	7.98	2378	8.57	2434	9.17	2490	9.79	2545	10.41	2601	11.05	2656	11.70	—	—	—	—	—	—
7596	4000	2396	8.76	2451	9.39	2504	10.02	2558	10.65	2611	11.29	2664	11.94	—	—	—	—	—	—	—	—
7976	4200	2473	9.60	2526	10.26	2577	10.92	2628	11.58	—	—	—	—	—	—	—	—	—	—	—	—
8356	4400	2551	10.49	2602	11.19	2652	11.88	—	—	—	—	—	—	—	—	—	—	—	—	—	—
8735	4600	2630	11.44	—	—	—	—	—	—	—	—	—	—	—	—	—	—	—	—	—	—

Performance certified is for installation type B—free inlet, ducted outlet.

Power Rating (BHP) does not include transmission losses.

Performance ratings do not include the effects of appurtenances (accessories).

Data in **bold** face indicates quietest and most efficient performance.

- Class I Blowers
- Class II Blowers

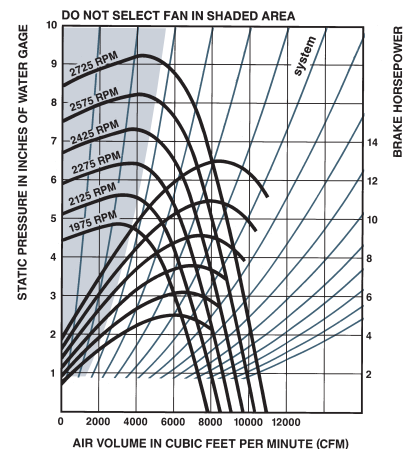
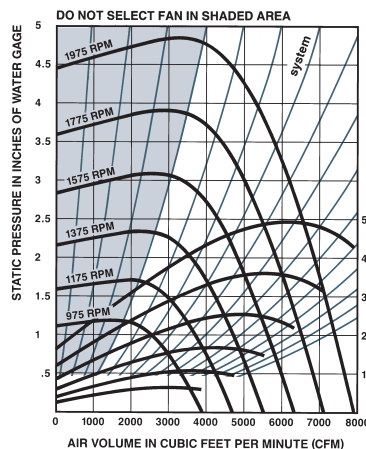

PEERLESS BLOWERS ULTRAFAN-PAK 2000 BLOWERS

Non-Overloading Belt Drive — Arrangement #10 — SWSI — Class 1

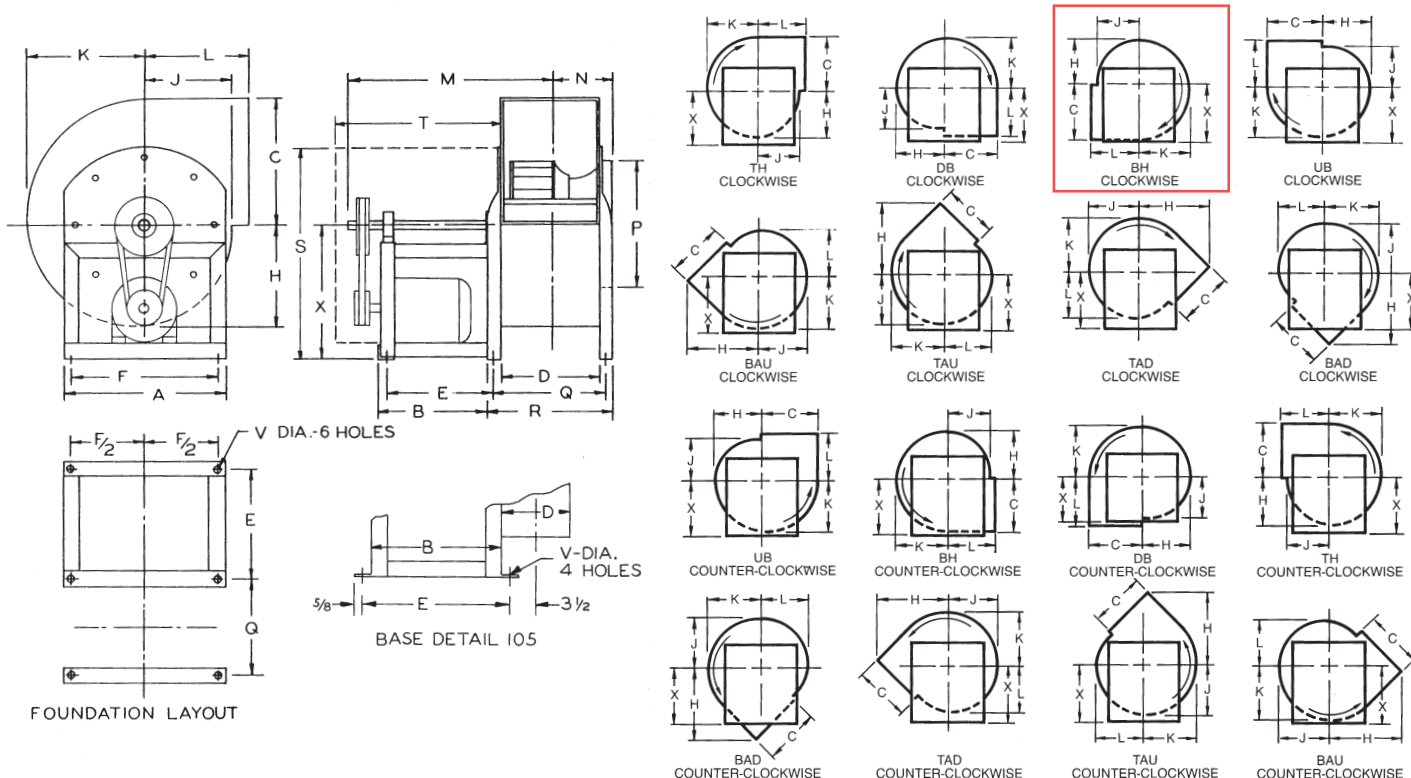

SIZE	WHEEL DIA.	SHAFT DIA.	A	B	C*	D	E	F	TH, DB, BH, UB STRAIGHT DISCHARGE				BAU, TAU, TAD, BAD ANGULAR DISCHARGE				M	N	P	Q	R	S	T	V	X	MAX. MOTOR FRAME
									H	J	K	L	H	J	K	L										
105	10 1/2	3/4	127/8	13	11 3/4	8	14 1/4	10 3/4	7 7/8	6 3/4	9 1/8	8 1/16	13 1/4	8 7/8	9 5/8	7 1/8	19 5/8	6	127/8	—	—	20 1/2	17	7 1/16	14	145T
122	12 1/4	1	163/8	13 1/2	13 1/4	9 5/8	13 3/2	14 3/4	10 1/8	8 1/2	11 1/2	10 1/2	16 5/8	10 3/4	12 1/2	9 1/8	23 7/8	6 3/8	13 1/4	11 1/4	12 3/4	25 1/4	20	1/2	17	182T
135	13 1/2	1	175/8	13 1/2	14 5/8	10 3/4	13 1/2	16	11 1/8	9 3/8	12 5/8	11 3/8	18 1/4	11 7/8	13 3/4	10	24 3/8	7	14 1/2	12 3/8	13 7/8	25 7/8	20	1/2	17	182T
150	15	1	19 1/4	15 1/2	16 1/4	11 3/4	15 1/2	17 5/8	12 3/8	10 3/8	14 1/8	12 3/8	20 1/8	13 1/4	15 1/4	11 1/8	26 7/8	7 1/2	16 1/8	13 3/8	14 7/8	27 5/8	22	1/2	17 7/8	182T
165	16 1/2	1	21 3/8	15	17 3/4	13	15 1/2	19 3/4	13 5/8	11 3/8	15 1/2	13 3/8	21 7/8	14 5/8	16 3/4	12 1/4	27 1/2	8 1/2	17 7/8	14 1/2	17	30 1/8	22	1/2	19 1/2	184T
182	18 1/4	1 3/16	23 1/8	17	19 5/8	14 1/4	17 1/2	21 1/2	15	12 5/8	17 1/8	14 5/8	24 1/8	16	18 1/2	13 5/8	30 5/8	9 1/8	19 5/8	15 3/4	18 1/4	33 3/8	25	1/2	21 7/8	184T
200	20	1 3/16	25	17	21 1/2	15 7/8	17	23 3/8	16 1/2	13 3/4	18 3/4	15 3/4	26 3/8	17 5/8	20 3/8	14 7/8	31 1/2	10	21 1/2	17 7/8	20 1/8	36 1/4	25	1/2	23 3/4	213T
222	22 1/4	1 3/16	27 3/8	16 1/2	24	17 3/8	17	25 3/4	18 1/4	15 1/4	20 7/8	17 1/4	29	19 1/2	22 5/8	16 1/2	32 3/4	10 5/8	23 7/8	19 3/8	22 5/8	39 3/4	26	1/2	26 1/8	213T
245	24 1/2	1 7/16	30 1/4	16 1/2	26 1/4	19 1/4	16 3/4	23 5/8	20 1/8	16 7/8	23	19 7/8	32 1/2	21 1/2	24 7/8	18 1/4	33 5/8	11 3/4	26 3/8	21 1/4	24 1/2	42 7/8	26	1/2	27 3/4	215T
270	27	1 7/16	33	16 1/2	29	21 1/4	16 1/2	26 1/4	22 1/8	18 1/2	25 1/4	21 1/2	35 3/8	23 5/8	27 3/8	20	34 5/8	12 5/8	29	23 3/4	26 1/2	47	26	1/2	30 1/2	215T
300	30	1 11/16	36 1/4	16 1/2	32 1/4	23 3/8	16 1/2	29 1/2	24 5/8	20 1/2	28 1/8	23 5/8	39 3/8	26 3/8	30 1/2	22 1/2	36	13 3/4	32 1/4	26	28 3/4	51 7/8	27	1/2	33 3/4	254T
330	33	1 11/16	39 1/2	21 3/8	35 3/8	25 7/8	21 5/8	33 1/8	27 1/8	22 1/2	30 7/8	25 5/8	43	28 7/8	33 1/2	24 3/8	41 3/8	15	35 3/8	28 3/8	31 1/8	58 1/2	30 3/8	7/8	38 3/8	254T
365	36 1/2	1 15/16	43 1/8	21 3/8	39 1/4	28 1/2	21 5/8	36 7/8	30	24 7/8	34 1/8	28	47 3/8	32	37 1/8	27	43 1/4	16 1/4	39	31	33 3/4	63 3/4	30 3/8	7/8	42 1/8	254T

NOTE: Letters "C" and "D" are outside housing dimensions.
 *"C" dimension on 105 extends 1 1/16" beyond center-line.

TEMPERATURE OPERATING LIMITS TEMPERATURE RPM DERATING FACTORS IN PERCENT:	
STEEL WHEEL	ALUMINUM WHEEL
300°F 100%	150°F 100%
301-400°F 96%	151-200°F 95%
401-500°F 92%	201-250°F 80%
501-600°F 85%	

PEERLESS BLOWERS... Your Clean Air Source!

Supplier of Quality Products for Industry:

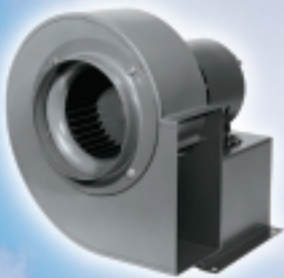

Direct Drive Fans



Pressure Blowers



Industrial Fans



Direct Drive Exhaust Fans



In-Line Centrifugal Fans



Backward Inclined Belt Drive Blowers



Belt Drive Propeller Fans



Powerfoil Fans



Plug-Pak Fans



Forward Curve Belt Drive Fans



PEERLESS BLOWERS

One Madison Avenue, P.O. Box 187
Hot Springs, NC 28743-0187
828/622-7500 • 1-800/613-4766 • Fax: 828/622-3309

www.peerlessblowers.com

E-Mail: sales@peerlessblowers.com



Registered to ISO 9001

CATALOG & BULLETIN INFORMATION

FOR

Aerator Media Scope of Supply

Type	Quantity	Layer Depth	Packaging
Polypropylene*	320 ft ³	60 in	10-ft ³ boxes

*Loose Fill media is field installed by others.

REV	REVISION DESCRIPTION	ECN	DESIGNER	APPROVER	DATE
<small>THIS DRAWING IS PROPERTY OF WESTECH ENGINEERING, INC. AND IS TRANSMITTED IN CONFIDENCE. NEITHER RECEIPT NOR POSSESSION CONFERS OR TRANSFERS ANY RIGHTS TO REPRODUCE, USE, OR DISCLOSE IN WHOLE OR IN PART, DATA CONTAINED HEREIN FOR ANY PURPOSE WITHOUT THE WRITTEN PERMISSION OF WESTECH ENGINEERING, INC.</small>					
DESIGNER	JO48	TITLE CATALOG & BULLETIN INFORMATION AERATION MEDIA SCOPE OF SUPPLY			
CHECKER	JO48	CLIENT WHITE RIVER WELL 3 VOC REMOVAL INDIANAPOLIS, INDIANA			
APPROVER	JO48				
DATE	08/23/2019				
FILE: 23925A-DS02-AERATION MEDIA SCOPE OF SUPPLY.docx		PROJECT 23925A	DOCUMENT NUMBER 23925A-DS02	SHEET 1 OF 1	REV -



LANPAC-XL[®]:
Advanced drip point technology



New, high efficiency tower packing combines extremely low pressure drop with excellent plugging resistance!

LANPAC-XL[®] new, advanced packing for use in:

- Air Strippers and Degasifiers
- High Efficiency Scrubbers
- Biological Treatment Systems

LANPAC-XL [®] Characteristics		
Dimensions	3.25" x 3.75"	83 x 95 mm
Effective surface area	74 ft ² /ft ³	242 m ² /m ³
Piece count	33 /ft ³	1165/m ³
Void fraction	95%	95%
Weight (polypropylene)	2.8 lb/ft ³	45 kg/m ³
Weight (PVDF)	5.5 lb/ft ³	88 kg/m ³
Packing factor	10/ft	33/m
Drip points	22,000/ft ³	776,600/m ³

- Advanced design increases gas/liquid contact surface
- Reduces capital costs for new towers
- Maximizes efficiency in shorter towers
- Reduces pressure drop through existing towers
- Allows for smaller, less expensive blowers
- Flow-through structure resists fouling
- Cuts maintenance costs and down time
- Reduces fan power consumption



LANPAC-XL[®] is NSF Certified

Lantec is the global leader in wet scrubbing and air stripping technology and has made countless technological advances for these applications.

Call Lantec for a free packed bed design!

Appendix C
Employee Safety Manual

EMPLOYEE SAFETY MANUAL



citizens
energy group™

SEPT 2017

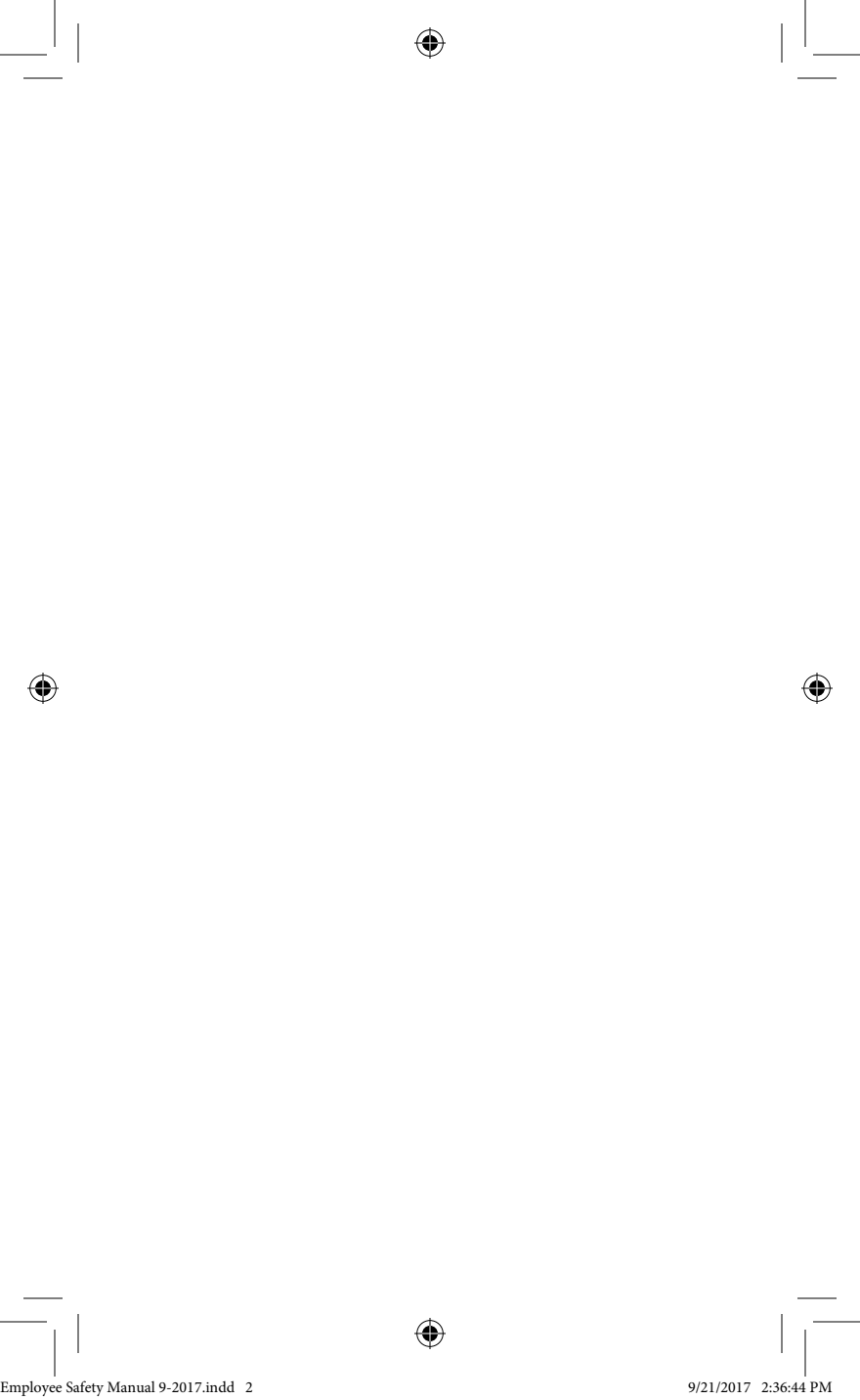



CERTIFICATION OF RECEIPT OF SAFETY MANUAL

I hereby certify that the Citizens Energy Group Safety Manual was discussed with me and I have been given a copy for my own personal reference. I understand and will comply to the best of my ability with the provisions set forth in this manual.

Printed Name _____

Signature _____

Employee # _____ Date _____



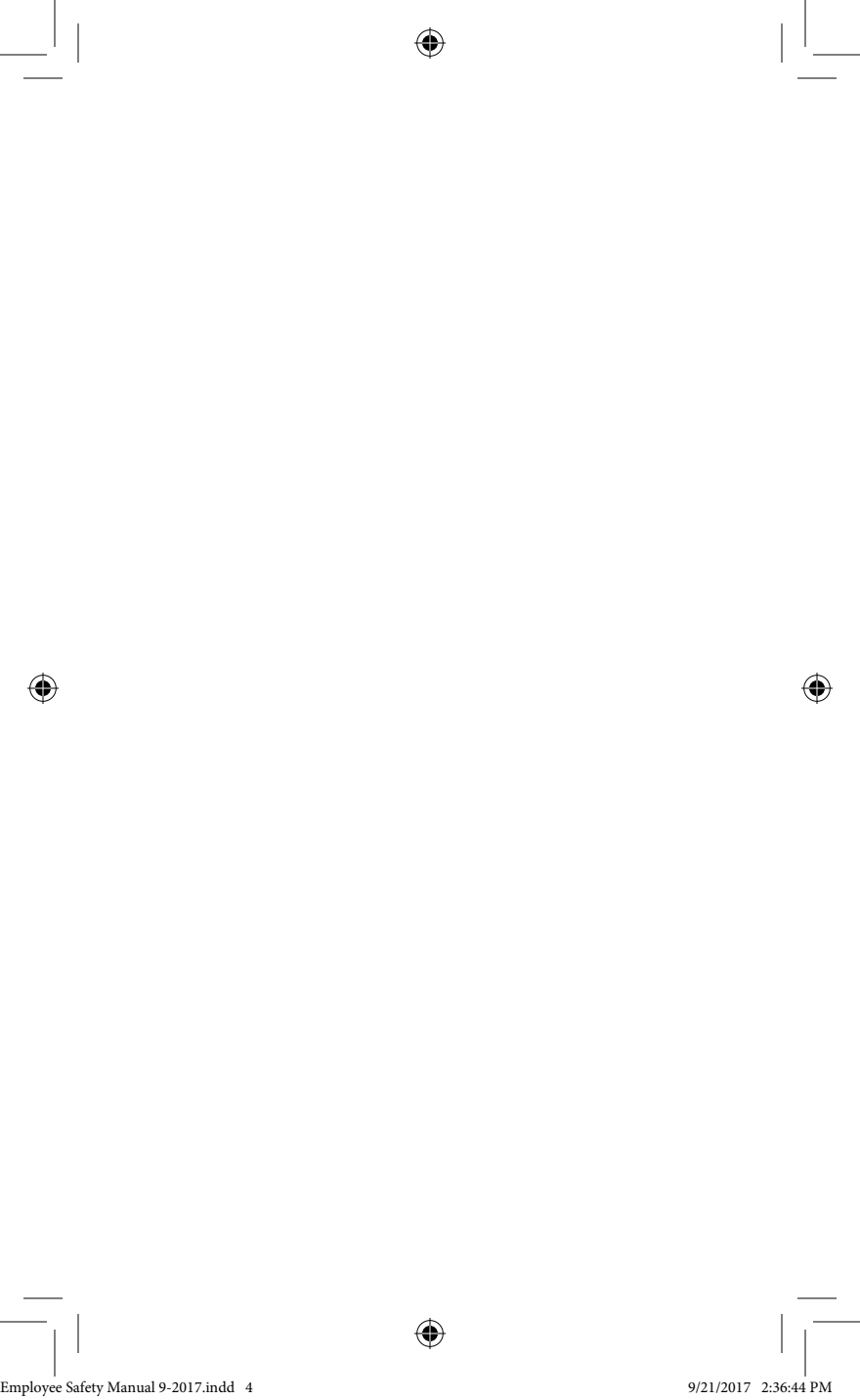



CERTIFICATION OF RECEIPT OF SAFETY MANUAL

I hereby certify that the Citizens Energy Group Safety Manual was discussed with me and I have been given a copy for my own personal reference. I understand and will comply to the best of my ability with the provisions set forth in this manual.

Printed Name _____

Signature _____

Employee # _____ Date _____



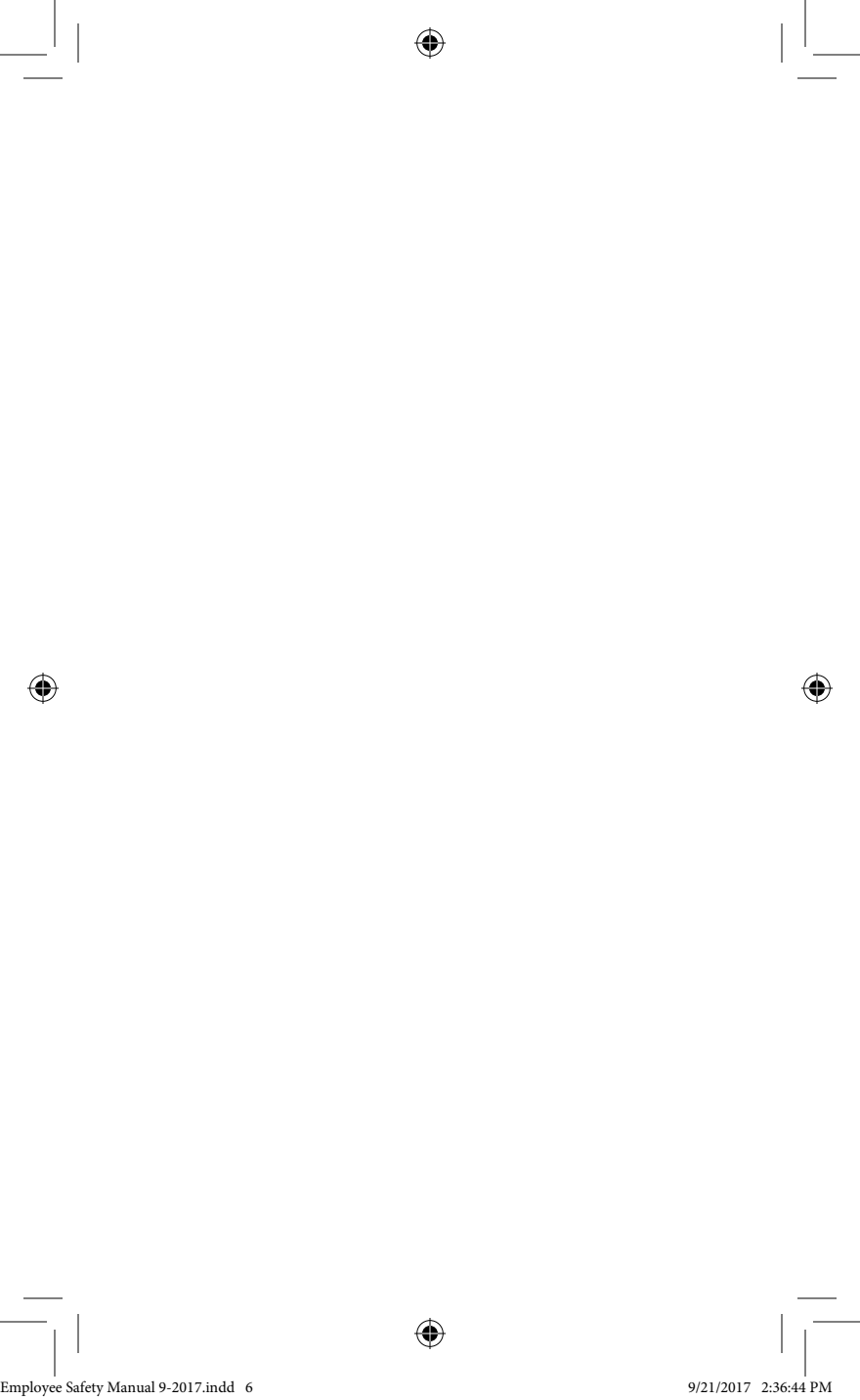

Table of Contents

FOREWARD	1
SAFETY POLICY	2
PRESIDENT'S LETTER	3
COMPLIANCE	4
EMPLOYEE QUESTIONS, CONCERNS AND SUGGESTIONS	5
SECTION ONE Employee Safety Responsibility	6
SECTION TWO Management Safety Responsibility	8
SECTION THREE Occupational Injuries Reporting and Treatment Options for Employee Injuries	8
SECTION FOUR.....	10
Personal Protection Equipment	
SECTION FIVE Housekeeping	13
SECTION SIX Fire Prevention	15
SECTION SEVEN Fire Protection	17
SECTION EIGHT Operation of Motor Vehicles and Work Equipment	20
SECTION NINE Protection of the Public.....	26

Table of Contents

SECTION TEN	
Material Handling - Manually	27
Material Handling - Fork Lift Type Equipment.....	28
SECTION ELEVEN	
Compressed Gases Cylinders	29
SECTION TWELVE	
Welding and Cutting Operations	29
SECTION THIRTEEN	
Hazardous Materials	31
SECTION FOURTEEN	
Ladders and Scaffolds	31
SECTION FIFTEEN	
Hand and Power Tools	33
SECTION SIXTEEN	
Electrically Powered Work Equipment and Machinery	36
SECTION SEVENTEEN	
Office Safety	37
SECTION EIGHTEEN	
Ergonomics	40
SECTION NINETEEN	
Confined Space Entry	41
SECTION TWENTY	
Excavation and Trenching.....	41
SECTION TWENTY-ONE	
Gas Division Requirements (includes dress policy)	42

Table of Contents

SECTION TWENTY-TWO	48
SECTION TWENTY-THREE	
Thermal Division Requirements	
(includes dress policy)	50
SECTION TWENTY-FOUR	
Shared Field Services Requirements	53
SECTION TWENTY-FIVE	
Emergency Action Plan	56

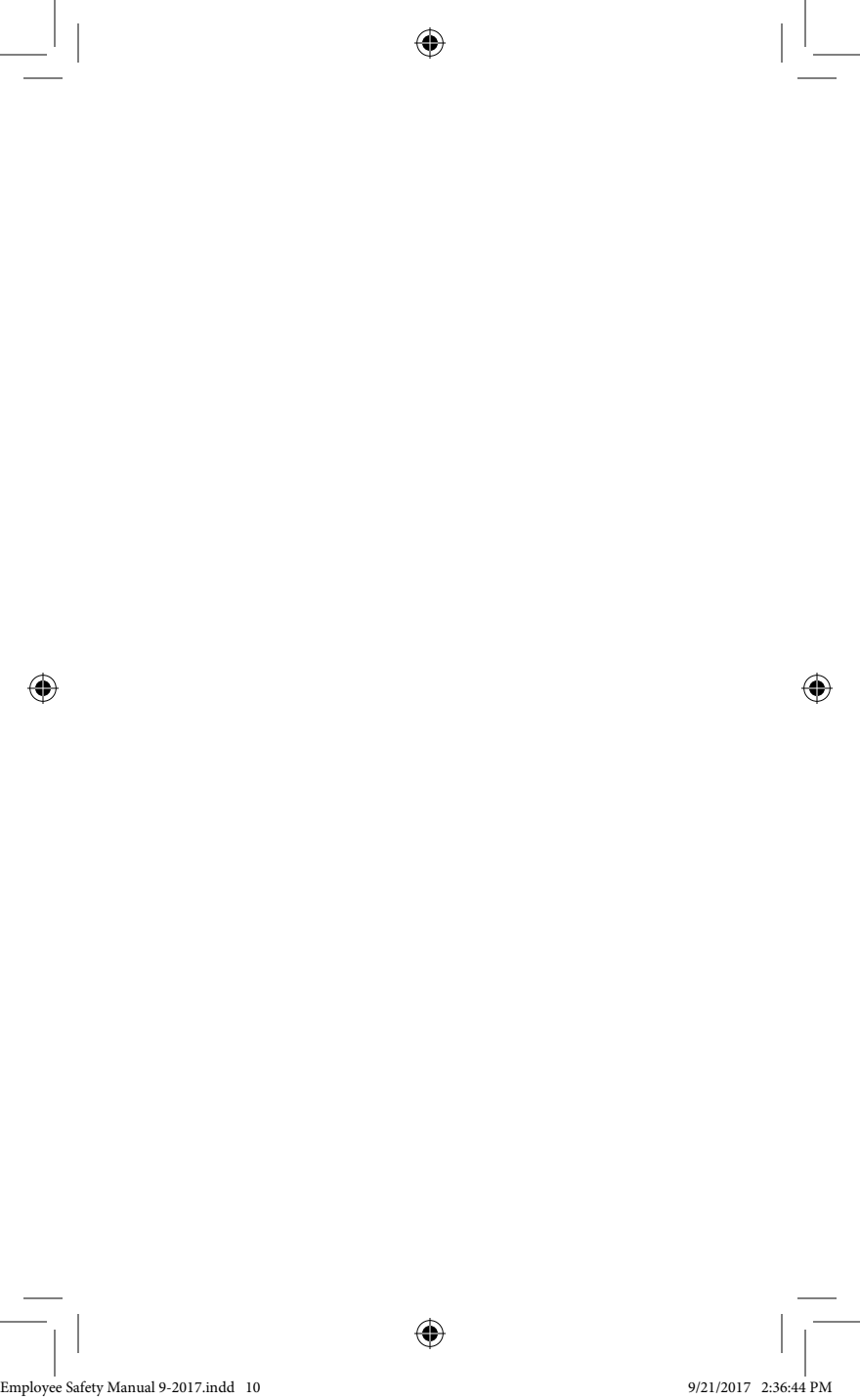





FOREWARD

The primary aim of this manual is **ACCIDENT PREVENTION**.

Every employee should become thoroughly familiar with, and will be expected to follow, the rules and regulations as stated in this Citizens' Energy Group (hereafter referred to as "Citizens'") Safety Manual. Each employee should use this book as a guide to help him/her in carrying out his/her work.



This book is not intended to supersede departmental or work area safety rules and all employees are expected to adhere to such rules and regulations. It is not practical to include safety procedures to meet all contingencies. Should any doubt arise as to the meaning or interpretation of any safety rule and the proper procedure to follow, the employee should obtain advice and direction from supervision or the person(s) in charge of the work. Ultimately, it is you that is responsible for your safety.





Citizens Energy Group Safety Policy

In order to promote, achieve, and insure the safe conduct of Citizens' operations for the benefit of all employees, customers and the general public, the following safety policy has been established:

1. We believe in the dignity and importance of each employee and each employee's right to derive personal satisfaction from work. This can be realized only when safety is the first consideration in conducting all operations.
 2. We expect a continuous awareness of safety considerations as an integral part of all operations. The goals of accident prevention and efficient operations must be inseparable.
 3. We will provide proper material, tools, equipment, and facilities in safe operating condition with proper material and sufficient training to achieve a safe work environment. This will allow all employees to devote their energies toward productive work performance, without fear of possible harm to life and health.
 4. We will require each employee to understand and strictly observe all safety rules and regulations. Enforcement of these safety rules and regulations is mandatory.
 5. We encourage all employees to participate in company safety committees to assist in continually improving employee safety.
- 
- 

Dear Fellow Employee:

This manual has been developed to provide a guide for each of us to follow to assure a safe work environment.

The safety of our employees is my highest priority. It is absolutely critical that we provide an environment in which all employees can work without accident or injury. We owe that to all employees and, just as importantly, to their families.

Therefore, please study this book, and understand its contents. Please also join me in making safety your utmost priority.

Sincerely,

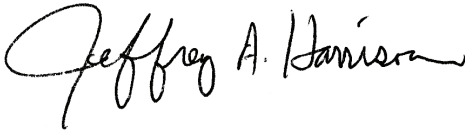
A handwritten signature in black ink that reads "Jeffrey A. Harrison". The signature is written in a cursive, flowing style.

Jeff Harrison

President and Chief Executive Officer



COMPLIANCE

Citizens' fully complies with all applicable laws (federal, state, and local) and with all applicable rules and regulations related to health and safety. In some cases, our programs and policies may exceed legal requirements to protect our employees, our communities and to better serve our customers.

Each division of the organization sponsors training programs for employees. These programs are either required by law or in addition to the minimum legal requirements for training. Training records are documented and maintained for each employee of the company.





All employees are expected to understand and comply with all safety and health policies and procedures. Violating established safety rules and regulations as stated in the Citizens' Work Rules will be proper cause for disciplinary action. It shall be understood that any employee that engages in serious, unsafe behavior that endangers self or others, can result in disciplinary action up to and including termination.





EMPLOYEE QUESTIONS, CONCERNS AND SUGGESTIONS

Safety is every employee's responsibility at Citizens Energy Group. If an employee has a concern or questions about safety, he/she should notify their supervisor or any member of management immediately. Employees will receive feedback to their question/concern promptly. Bargaining employees may choose to discuss the issue with their union steward. In addition, all Divisions have safety committees that meet periodically to review concerns and improve processes and policies in the area of safety that are specific to their division. The division safety committees involve both management and union representation. Employees are free to raise concerns to these committees as well. If desired, the employee may submit his/her question or concern in writing. Citizens also sponsors a Central Safety Committee; the members are representatives from each division of the organization and the Corporate Office. This team is an oversight committee and reviews trends and legislative updates in the area of safety. The Central Safety Team also makes policy recommendations to corporate and division management regarding company-wide issues. For more information about your safety committee contact your divisional Safety Department representative.









SECTION ONE

Employee Safety Responsibility

Following is an outline of the organizations basic safety expectations of all employees. Each division and area has their own specific policies and expectations as well that employees are required to know before working in that area. Also, please reference that organizations Work Rules booklet that lists additional expectations.

- 1.1 Each employee is responsible for performing his/her duties in a manner to minimize the possibility of damage to property or injury to employees or to the general public.
 - 1.2 Each employee is required to have a thorough knowledge of all safety rules applying to his/her work areas
 - 1.3 If an employee is instructed to perform work that he/she considers unsafe or observes any hazardous condition, it is his/her responsibility to immediately bring the matter to the attention of his/her immediate supervisor or any other member of management.
 - 1.4 Before starting assigned work, each employee must thoroughly understand the work and any known potential hazards he/she may encounter. He/She will be responsible to employ the necessary safety measures to safeguard themselves and fellow employees. When applicable, a job safety analysis (JSA) for the task should be reviewed to identify hazards, assess the risks, and outline the safest way to perform the work.
- 

- 
- 
- 
- 1.5 It will be the responsibility of each employee to report to his/her job in good mental and physical condition to perform his/her tasks without jeopardy to themselves or fellow workers.
 - 1.6 Intoxicants or narcotic drugs will not be used while on duty and are forbidden on the company premises or at any job location. Employees reporting for duty under the influence of intoxicants or drugs that impair physical or mental reflexes will not be permitted to work. Employees that are taking prescription medication that may interfere with their ability to safely perform their jobs must report taking those prescription medications to their Supervisor. Please see the Drug and Alcohol Policy for the individual divisions.
 - 1.7 Practical jokes, horseplay, fighting and rowdyism are dangerous, unnecessary, and strictly forbidden at all times.
 - 1.8 Under no circumstances will safety be sacrificed for expediency or speed. Safety will be considered the prime factor at all times.
 - 1.9 Jewelry Restrictions/Dress policies - Please refer to separate divisional sections regarding specific details on jewelry restrictions and appropriate dress requirements.
 - 1.10 Failure to comply with the Safety Manual is in direct violation of company work rules.

SECTION TWO

Management Safety Responsibility

The purpose of this section is to ensure that management supports and takes responsibility to uphold this policy. The following is management's expectations in the area of safety.

- 2.1 Management will provide safety instructions for employees under their supervision.
- 2.2 Management will meet or exceed all regulatory training requirements.
- 2.3 Management will review incidents and root cause(s), and make corrections to work areas to prevent future accidents.
- 2.4 Management will require safe work habits from their employees.
- 2.5 Management will be aware of potential hazards in their respective areas of operation.
- 2.6 Management will support safety in its entirety.
- 2.7 Management will be responsible to carryout disciplinary actions when required in the event of a safety rule violation.

SECTION THREE

Occupational Injuries

Reporting and Treatment Options for Employee Injuries

All work related injuries, whether minor or serious, shall be reported immediately via telephone

or in person to supervision without exception. Supervision will report all injuries immediately to their divisional safety representative and Certified Early Intervention Specialist (CEIS). Supervision (with safety representative and CEIS) will determine if the injury needs medical treatment. Details of the injury will be documented and reviewed by the safety department.

Injuries requiring treatment for Greene County employees will be provided by Greene County General Hospital Emergency Room, located at the corner of Hwy. 54 and Lonetree Road just east of Linton, Indiana.

Emergency Cases Requiring an Ambulance: Call 911 if possible and then call an authorized person (dispatch at Langsdale, Main Control Room at the Thermal Energy Division, and Security at the corporate office). All hospital cases will be sent to IU Health for treatment.

For all work-related injuries or illnesses, supervision must submit appropriate documentation within **24 hours** of incident to division safety representation for review.

- 3.1 The company retains a number of Occupational Treatment Centers for consultation and/or treatment of injuries and illness. Refer to the back cover of this manual.
- 3.2 **Reports:** All injuries must be reported on the appropriate injury form located on Safety's iTrust page by the injured employee and his/her Supervisor within 24 hours of the injury.
- 3.3 Divisional safety representatives will assist

- and follow-up with all injuries.
- 3.4 The division safety representative must be notified immediately of all emergency case(s).
 - 3.5 Important Emergency Numbers: refer to the back cover of this manual.

SECTION FOUR

Personal Protective Equipment (PPE)

Below are general requirements: Departments may have additional safety and procedural requirements. Contact divisional safety representation for area safety specific requirements.





Note: Citizens' will furnish Personnel Protective Equipment (PPE) as needed or required by divisional safety requirements.

Jewelry or any type of personal accessory shall not impede the proper use of PPE.

- 4.1 **Head Protection:** Approved hard hats will be worn by employees in designated areas or as required by divisional standards.



Headwear (i.e. bandannas) shall not interfere with hard hat fit; loose ends beyond knot shall be secured inside outer shirt or jacket. Hair style or hair length shall not interfere with the fit of the hard hat.

- 4.2 **Eye Protection:** ANSI approved safety glasses, full cover goggles or face shields will be worn by employees in designated areas or as required by divisional standards.

- 
- 
- 
- 
- 4.3 Hearing Protection: Approved hearing protection will be worn by employees in designated areas or as required by divisional standards.
 - 4.4 Welding Hoods: Welding hoods, or welding goggles, will be worn by employees in designated areas or as required by divisional standards.
 - 4.5 Sand Blasting Hoods: Sand blasting hoods will be worn by employees in designated areas or as required by divisional standards.
 - 4.6 Respiratory Protection: Proper breathing apparatus will be used by employees as required by company standards and State and Federal Regulations.
 - 4.7 Safety Shoe Program: See division safety representative for requirements under this program.
 - 4.8 Appropriate Footwear for Employees: All employees will wear appropriate footwear that will provide adequate and secure footing. When required, safety toe shoes will be subsidized by divisional requirements under the safety shoe program and will be worn by employees.
 - 4.9 Protective Clothing General:
 - A. Arc flash clothing required by division will meet or exceed NFPA standards.
 - B. Employees are required to wear sleeved shirts which cover the shoulders, when engaged in construction, maintenance, and other phases of operations.



Employees are required to wear full length sleeves while performing certain designated work assignments. Uniforms may be provided.

- C. Safety vests or other Hi-Viz, class 2 protective vests, shirts or outer wear are required when employees are exposed to moving vehicular traffic while on a company worksite, or when employees are engaged in traffic control at any worksite.
 - D. Employees working in the presence of escaping natural gas will be required to wear flameproof coveralls and hoods with complete face protection.
 - E. Protective gloves will be worn when engaged in specified work operations.
 - F. Leather welding sleeves will be worn when engaged in welding operations except when supervision determines that the employee's personal clothing provides adequate protection.
 - G. When engaged in any operation, not specified above, employees are required to wear such protective clothing as required. Contact divisional safety representation and supervision to develop and review the Job Hazard Analysis (JHA) for the task.
 - H. In addition to the personal protective equipment provided for in Section Four, employees will provide and wear sufficient clothing and apparel to
- 
- 







protect themselves from the elements and weather conditions such as extreme cold or exposure to the sun.



- I. Employees that work outside are also encouraged to use sun screen, sun glasses and other means to protect themselves from the harmful UV rays of the sun.

SECTION FIVE

Housekeeping

- 5.1 Employees will cooperate in keeping all company facilities, buildings, equipment, and work sites in a clean, neat, and orderly condition.
 - 5.2 Waste material, trash, and refuse will be deposited in containers provided and disposed of in the proper manner. Paper and other combustible materials will not be allowed to accumulate at facilities, job sites, or in company vehicles or equipment.
 - 5.3 Materials, tools, and chemicals will be stored in their proper places in a manner that assures their safe storage.
 - 5.4 Stairways, floors, walks, runways, platforms, hallways, and job sites will be kept free of anything that can create tripping or slipping hazards.
 - 5.5 All facilities such as restrooms, lunchrooms, and drinking fountains will be maintained in a neat and sanitary condition. Food and drinks will not be permitted in restrooms.
- 
- 

- 
- 
- 
- 5.6 Combustible materials, such as oil soaked rags, waste, and shavings will be kept in approved metal containers with lids. Containers will be labeled to indicate the material being stored. Containers will be emptied as soon as practical.
 - 5.7 Storage of supplies, materials, equipment, and tools will not obstruct or prevent access to exits, fire-fighting equipment, or signs installed to insure the safety of personnel or property.
 - 5.8 Citizens' employees are prohibited from using tobacco products on any property owned or leased by Citizens at all times, including breaks and meal times. This includes all walkways, buildings, grounds, and parking lots. Employees are also prohibited from using tobacco products while in company owned or leased vehicles and privately owned vehicles while on company property.
 - 5.9 During working and non-working hours, employees are required to be respectful of residents and businesses neighboring premises by refraining from using tobacco products within one half mile of any company property except when patronizing the specific business, or by discarding tobacco products in such a way that negatively reflects on the organization.
 - 5.10 Whenever a job is in progress involving open floors, excavations, or any tripping or falling hazards, adequate guarding and warning devices will be utilized to protect employees and the public from such hazards.

- 
- 
- 5.11 Operators and certified contractors of company mechanized equipment, such as motor vehicles, digging equipment, and cranes will be responsible for maintaining the operating compartment in a neat and orderly condition. All windows will be periodically cleaned to insure adequate vision for the safe operation of such equipment.
 - 5.12 Good housekeeping is a prime factor in eliminating hazards on the job and will be afforded top priority at all company facilities and job sites.
 - 5.13 When work is performed on a customer's premises, the work area will be restored to a clean and orderly condition when the job is complete.





SECTION SIX

Fire Prevention

- 6.1 Good housekeeping is a prime factor in minimizing fire hazards.
- 6.2 Combustible materials will not be placed within 3 feet of electrical panels or 5 feet of combustion appliances such as furnaces, boilers, or other flammable materials.
- 6.3 Paper and other combustible materials will not be allowed to accumulate. Weeds or other rank vegetation will be controlled in or around the vicinity of regulator stations, pipe storage yards, buildings, tank farms or other structures.
- 6.4 Flammable liquids such as gasoline,



benzene, naphtha, lacquer, thinner, etc., will not be used for cleaning purposes unless adequate ventilation and approved methods are employed for their safe use.

- 6.5 In any building (except one provided for their storage) flammable liquids such as gasoline, benzene, naphtha, lacquer, thinner etc., will be limited to a total of five gallons (a flammable liquid is a liquid which has a flashpoint of no more than 93°C). These flammable liquids will be stored in U.L. approved containers properly labeled. Do not put gasoline into plastic containers. For specific information regarding a liquid's flammability refer to the SDS for that liquid.
 - 6.6 Labeled containers will be used only for the product for which they are labeled.
 - 6.7 Petroleum products such as motor oil, hydraulic fluid, etc., will not be allowed to accumulate in pools on garage floors or in service cages at Company installations.
 - 6.8 The use of open flame devices will be prohibited in areas where flammable liquids are used, stored, transferred, or in any other area where a combustible gaseous atmosphere could potentially prevail. This applies both on and off company property.
 - 6.9 Hot Work Permits will be completed and hot work procedures shall be adhered to per divisional requirements.
- 
- 

SECTION SEVEN

Fire Protection

- 7.1 The Facilities Department, in conjunction with the Safety Department, will make provisions for preventing and combating fires in his/her area of control or responsibility.
- 7.2 Properly maintained firefighting equipment is essential. It will be located in the most accessible places and each employee will be familiar with its location and the use of such equipment.
- 7.3 All firefighting equipment will be periodically inspected as required by OSHA to ascertain that it is in its proper location and has not been tampered with or otherwise damaged or rendered inoperative. Portable fire extinguishers shall be inspected monthly by a Citizens' employee or outside contractor (as determined by Facilities) to verify that extinguishers are in the proper location and in satisfactory operating condition. Vehicle mounted extinguishers must be inspected monthly by the vehicle operator. All portable extinguishers must be inspected annually by an approved outside contractor. A tag attached to such firefighting equipment will show the date of the last inspection and the identification of the person performing the inspections.
- 7.4 Installed fire hoses will be used for housekeeping only and shall not be used for firefighting.

7.5 After any fire extinguisher has been used or damaged in any way, the fire extinguisher will IMMEDIATELY be returned to the storeroom by the employee for proper servicing before it is returned to its designated location. Citizens' Storeroom personnel will be notified and provide for a suitable replacement extinguisher until the designated extinguisher is serviced and returned to its proper location. NEVER RETURN A FIRE EXTINGUISHER THAT HAS BEEN USED TO ITS LOCATION UNTIL IT HAS BEEN PROPERLY SERVICED.

7.6 Fire doors will be inspected annually for the condition of the fusible links, frames, overall condition and for obstructions that would interfere with their proper operation.

7.7 Persons in charge of company installations having Emergency Fire Fighting procedures will periodically review such plans to ascertain that they are updated and functional.

7.8 Fire hydrants, standpipe, sprinkler, and alarm systems will be inspected according to the following schedule:

Standpipe & Sprinkler Systems	Monthly
Alarm Systems	Monthly
Hydrants	Monthly
Gauges	Weekly

7.9 Appropriate operational personnel will receive periodic training in firefighting to maintain proficiency in combating fire emergencies. The Safety Department or

outside service provider will provide this training.

- 7.10 Fires are divided into five general classifications. The type of extinguisher to be used on these types of fire is as follows:

Class A: For fires in ordinary combustible materials such as wood, paper, rags, etc., use pressurized water extinguisher, foam extinguisher, or any other type of water yielding device such as a garden hose, fire hose, etc. Extreme care must be exercised when using water near electrical devices.

Class B: Fires in flammable liquids and gas where a blanketing effect is essential. Use a dry chemical, carbon dioxide, or foam type of extinguisher.

Class C: Fires in electrical equipment where use of a non conducting extinguishing agent is of primary importance. Use dry chemical or CO₂ extinguisher. **DO NOT USE WATER OR AN EXTINGUISHER THAT HAS A WATER COMPONENT IN THE EXTINGUISHING AGENT.** Computer rooms, Control Rooms and other areas with significant electronic equipment should be protected by extinguishing agents designed for those areas.

Class D: Combustible Metals, especially alkali metals like lithium and potassium, alkaline earth metals such as magnesium, and group 4 elements such as titanium and zirconium.

Class F: Cooking oils and fats





- 7.11 Employees will not enter confined spaces

where carbon dioxide, Freon or other fire extinguishing agent has been used until the area has been properly ventilated.



SECTION EIGHT

Operation of Motor Vehicles and Work Equipment

- 8.1 Only authorized employees who possess a valid state operator's license of the proper classification will operate Company owned motor vehicles on company business. The policies and procedures outlined in the Citizens' Fleet Safety Program will be followed.
- 8.2 Company owned mechanized work equipment will be operated by only those employees authorized to do so.
- 8.3 Drivers will be familiar with and obey all state and local motor vehicle laws.
- 8.4 A driver will not permit unauthorized persons to drive, operate, or ride in a company vehicle.
- 8.5 Seat belts must be worn at all times where applicable this includes construction equipment and vehicles when in motion.
- 8.6 Employees will ride only in proper passenger space in company trucks and equipment. They will not ride on running boards, open truck beds, tail gates, or any other unsafe place on vehicles.
- 8.7 Employees will not jump on or off company vehicles and/or work equipment.

- 
- 
- 
- 
- 8.8 Fuel tanks on company vehicles and equipment will be filled to the point of the automatic shut off of the nozzles on the fuel dispensers.
- 8.9 When refueling company vehicles and equipment, the motor must be turned off, no smoking is permitted, and no cell phone use is permitted.
- 8.10 Windshields and windows of company vehicles and equipment will be kept free of any substance that will obscure the driver's vision. No unsecured items will be left on the dashboard.
- 8.11 Each vehicle shall be inspected by a "walk around" inspection at least once each day. All equipment necessary for the safe operation of company vehicles and equipment such as lights, horn, mirrors, brakes, and tires will be inspected daily. Unsafe vehicles should be presented or reported to the garage for repair. Do not operate unsafe vehicles. Persons employed in the Underground Storage Department in Greene County will report such defects to the immediate supervisor. Recommended checklists are online at:

https://itrust.citizensenergygroup.com/departments/safety/safety_documents/_layouts/15/WopiFrame.aspx?sourcedoc=/departments/safety/safety_documents/Shared%20Documents/Fleet%20Safety/Vehicle%20Inspection%20Checklist.docx&action=default

- 
- 
- 8.12 Loads on company vehicles and equipment will be properly secured so that they do not protrude, shift, leak, or fall from the vehicles.
 - 8.13 Company equipment having booms, buckets, or any other type of out rigging will have such equipment secured in a safe manner before operating on the streets or highways or before being parked or left unattended.
 - 8.14 Company work equipment will only be operated or moved when the operator is properly positioned or seated at the controls of such equipment. Under no circumstances will another person be allowed to ride on work equipment while the vehicle is in motion.
 - 8.15 Employees will not be permitted to ride in buckets of digging equipment or the lifting and lowering devices of material handling machines such as cranes, high lifts, etc.
 - 8.16 Servicing, adjusting, or repair of moving parts of machinery, i.e., belts, pulleys, drive shafts, power take off, etc., will not be performed when the machine is running.
 - 8.17 Company vehicles and equipment will be operated at a speed which will insure full control and safe operation at all times regardless of the weather and other conditions
 - 8.18 Backing of company vehicles and equipment should be avoided whenever possible. When necessary to back, a guide or helper will be used whenever possible. Under all







circumstances extreme care and caution will be exercised when backing.

- 8.19 Defensive driving will be practiced at all times and right of way is something which will always be yielded and not contested with other drivers.
- 8.20 Company vehicles and work equipment, if left running, will be secured in a safe condition.
- 8.21 The speed limit in all plant areas and other company properties will be 15 mph unless posted otherwise. All other traffic signs and controls posted in the facility will be obeyed.
- 8.22 Operators of company vehicles and equipment will operate such vehicles and equipment in such a manner so as not to cause undue stress, strain, or damage to the vehicle and/or equipment.
- 8.23 It is impossible to describe in detail the many ways company drivers and operators might prevent an accident without being primarily or legally responsible. The following definition of Defensive Driving will be the criteria whenever operating company vehicles and equipment. “A DEFENSIVE DRIVER” is one who commits no driving errors himself/herself and makes allowances for the lack of skill or improper driving practice of the other driver. “A DEFENSIVE DRIVER” adjusts his/her own driving to compensate for unusual weather, road and traffic conditions, and is



not tricked into an accident by the unsafe actions of pedestrians and other drivers. By being alert to accident inducing situations he/she recognizes the need for preventive action and takes the necessary precaution to prevent the accident. As “A DEFENSIVE DRIVER”, he/she knows when it is necessary to slow down, stop, or yield his right of way to avoid involvement.

- 8.24 All vehicular accidents must be immediately reported on an appropriate company vehicle accident form. Regardless of the amount of damage, ALL ACCIDENTS WILL BE REPORTED.
 - 8.25 Whenever damage occurs to property due to the operation of company work equipment, it will be immediately reported to supervision. This refers to all damage other than that sustained as the result of a motor vehicle accident.
 - 8.26 Whenever a company vehicle is involved in an accident the driver must stop, render aid and assistance to any injured, exchange information with other parties involved, obtain the names of witnesses, and notify the appropriate dispatcher or supervisor, who will contact the appropriate law enforcement agency.
 - 8.27 Company drivers will not engage in discussion with other parties involved as to who is responsible for the accident. Additionally, they will not make any concessions or promises pertaining to liability or settlement.
- 
- 

- 
- 
- 
- 8.28 When operating or servicing motor vehicles or work equipment, adequate ventilation of carbon monoxide gases will be provided.
- 8.29 Company employees shall not use Mobile Communication Devices while operating a motor vehicle on company business. Employees also shall not use Mobile Communications Devices for business purposes related to Citizens' Energy while operating any motor vehicle for any reason. Refer to Policy Release #1038
- 8.30 Mobile Communication Devices refers to: smart phones, GPS units, pagers, two-way radios or any other mobile device that makes or receives phone calls, sends or receives text or e-mail messages, or surfs the internet. Mobile Communication Devices includes both company-owned and personally owned devices.
- 8.31 Exceptions to 8.29 Mobile Communications policy:
1. Calls placed to 9-1-1,
 2. The use of two-way radios limited, as much time as possible, to use while the vehicle is NOT in motion.
 3. Company declared emergencies
- 8.32 Headphones shall not be worn unless required for hearing protection.





SECTION NINE

Protection of the Public

- 9.1 While doing work of any kind, every precaution will be taken to protect life and property. In the case of obstruction in the streets or walkways, warning in the form of danger signs, barricades, traffic cones, and other control devices will be displayed as specified in departmental operating manuals.
- 9.2 The employee will exercise care to protect the customer's property. Any damage inflicted to a customer's property will be reported to management.
- 9.3 When it is necessary to leave pipe or equipment at a work site adjacent to a highway, street, or alley, it should be stored away from the traveled portion thereof and in such a manner so as not to create undue hazard or impairment. Such pipe and equipment will be adequately secured so that it will not roll or move.
- 9.4 Unauthorized persons will be prevented from approaching locations or work sites where hazardous work is being performed. This may be accomplished by the use of signs, barricades, fencing, etc. Citizens' employees may never use physical force in removing or preventing the presence of an unauthorized person in work zones or hazardous locations unless the unauthorized person is in imminent danger of being seriously injured.





- 
- 
- 
- 9.5 Employees will not permit the customer or the public to assist in the performance of their work except in emergencies when life is endangered.
 - 9.6 Street cuts and excavations that must be left open and unattended will be properly guarded and lighted so as to warn the public of danger.
 - 9.7 Employees responding to a gas emergency will, as soon as possible, inform the customer of the situation and suggest what emergency measures should be taken. Citizens' employees may not require evacuation of an area or building but should contact the fire department via 911 to have any hazardous area evacuated.
 - 9.8 Contractors and service providers must comply with all rules, regulations, and the Citizens' Contractor Safety Manual. Contractors and service providers must obtain authorization and notify applicable Citizens' personnel prior to beginning work.

SECTION TEN

Material Handling - Manually

- 10.1 An employee will obtain assistance in lifting excessively heavy or large unwieldy objects or use power equipment if available.
- 10.2 When two or more persons are carrying one object, each employee, if possible, will face the direction in which the object is being carried.

- 
- 
- 10.3 Employees handling material should wear appropriate protective equipment such as gloves, safety shoes, etc., to protect him/her from sustaining injuries such as cuts, bruises, etc.
 - 10.4 The operator will visually inspect winch lines, ropes, and/or cables prior to using material handling equipment, if so equipped.
 - 10.5 Employees shall be trained and utilize proper lifting techniques when lifting regardless of the weight or configuration of the item being lifted. Get help with heavy loads, when lifting keep your back straight and break large loads down into smaller sections.



Material Handling Fork Lift Type Equipment





- 10.6 Operators will be trained, tested, and in compliance with IOSHA requirements and according to division requirements and procedures prior to operating such equipment.
- 10.7 Fork trucks must be inspected at least once daily when in use. This inspection must be documented on the form provided by the Storeroom or Safety Department. Inspection forms should be kept on file either in the Storeroom or in the Maintenance Department. Fork trucks found to be unsafe must be taken out of service and the garage notified for service.
- 10.8 Materials must be stored in a manner that prevents sliding, falling or collapsing.



SECTION ELEVEN





Compressed Gases Cylinders

- 11.1 Compressed gas cylinders shall be stored and secured in approved areas.
 - 11.2 Compressed gas cylinders shall be clearly marked for the type of gas contained.
 - 11.3 Oxygen and fuel gas cylinders must be stored at least 20 feet apart or separated by a five (5) foot high fire wall with a 30-minute fire rating. Oxygen-acetylene bottles on welding carts are considered to be “in use” and are not subject to this rule.
 - 11.4 All cylinders are to be stored and transported in an upright/vertical position. Caps are required to be securely in place when cylinders are not in use.
 - 11.5 Cylinders used in association with oxy-gas welding or cutting activities must be equipped with flashback arrestors.
 - 11.6 Cylinders can only be secured upright/vertical by using steel chain, metal straps, steel cable or synthetic material designed for securing Compressed Gas Cylinders. Unacceptable material includes rope, electrical wire, tie wraps, bailing wire, etc.
- 
- 

SECTION TWELVE

Welding and Cutting Operations



Welding and Cutting Operations must comply with Division and Regulatory requirements

- 
- 
- 
- 
- 12.1 The area surrounding and below a cutting or welding operation must be kept free from material such as paper, wood, cardboard, flammable liquids, etc. Cylinders shall be located so that sparks, hot slag, or flame will not reach them or fire resistant shields shall be provided.
 - 12.2 A fire extinguisher (minimum 20 lb. with ABC fire rating) and a qualified fire watch shall be stationed near the cutting or welding operations with the exception of open shop areas.
 - 12.3 Welding cables and connectors shall be properly insulated, flexible, and rated for the type of current that is used.
 - 12.4 No welding cables with splices or repaired areas within 10 feet of the electrode holder shall be used.
 - 12.5 Welders shall not be grounded on pipelines containing flammable gases, liquids or electrical current. Also welders shall not be grounded to fencing.
 - 12.6 Employees shall be protected with the proper personnel protective equipment in accordance with IOSHA or divisional safety requirements when performing cutting or welding operations.
 - 12.7 Whenever practicable, all arc welding and cutting operations shall be shielded with noncombustible or flameproof screens to protect employees and other persons (who are not wearing appropriate PPE) working in the vicinity from the direct rays of the arc.



SECTION THIRTEEN

Hazardous Materials

- 13.1 It is each employee's responsibility to read and comply with the container label, note the instructions for proper use and precautions, as well as, personal protective equipment, prior to handling hazardous chemicals.
 - 13.2 The company will comply with all applicable OSHA regulations pertaining to hazardous materials.
 - 13.3 The company will make available Safety Data Sheets (SDS) for those chemicals in each employee's work area and provide training for safe use.
 - 13.4 Employees will consult with the Supervisor and/or Safety Representative concerning any chemical or solvent for which there is no SDS or where employee is not familiar.
 - 13.5 If a question arises concerning the proper disposal procedures for hazardous materials, the employee must contact the division's safety representative who will defer to the environmental department when appropriate.
 - 13.6 All chemicals must be procured through Supply Chain or be approved by the Safety Department or Environmental Stewardship.
- 
- 

SECTION FOURTEEN

Ladders and Scaffolds





The use of ladders and scaffolds must comply with Division and Regulatory requirements

Ladders

- 14.1 Only ladders provided by Citizens will be used. Each ladder shall be visually inspected prior to use.
- 14.2 Employees will not use a ladder that has broken, loose or cracked rungs, side rails, or braces.
- 14.3 When ascending or descending a ladder the user shall face the ladder and use both hands, maintaining 3-point contact at all times.
- 14.4 Straight ladders will not be used unless equipped with approved safety shoes/ cleats. The distance from the foot of the ladder to the support it rests against should equal one fourth the length of the ladder.
- 14.5 Employees will not work or stand on either of the two top rungs of the ladder.
- 14.6 Ladders in use will be secured to prevent slipping or being displaced. Whenever possible, the ladder should be tied or blocked.
- 14.7 Boxes, crates, or chairs will not be used to stand on while working.
- 14.8 All ladders that are not in use must be stored in approved areas or in an orderly manner away from foot traffic.

Scaffolds





The use of scaffolding must comply with Division and Regulatory requirements



- 
- 
- 
- 14.9 Scaffolding shall be erected, moved, altered or dismantled only under the supervision and direction of a competent person qualified in these activities. Only experienced and trained employees selected for such work by the competent person shall perform such activities.
 - 14.10 Scaffolds shall be equipped with top rails, mid rails and toe-board and shall be fully planked.
 - 14.11 All planking shall be scaffold grade material and must not be cracked, painted, or chipped in any way.
 - 14.12 Scaffold and scaffold components shall be inspected by a competent person for visible defects before each work shift and after any occurrence which could affect the scaffold's structural integrity.
 - 14.13 All scaffolding shall be erected on base plates, and mud-sills or adequate firm foundation and shall be rigid and capable of carrying the maximum intended load without settling or shifting.

SECTION FIFTEEN

Hand and Power Tools

- 15.1 All hand and power tools will be maintained in good condition with guards in place
- 15.2 Employees must use the correct tool for the job. If modifications are needed to make use of tools ergonomically correct employees should notify the supervisor.

- 
- 
- 
- 
- 15.3 The employee will satisfy himself/herself that all tools that are used on the job are in safe condition and that any unsafe or defective tools are tagged for repairs or replaced.
 - 15.4 Tools will not be thrown from place to place or person to person under any circumstances.
 - 15.5 Tools with sharp edges will be stored so that they will not cause injury or damage.
 - 15.6 When impact tools such as chisels, punches, or drills become mushroomed or cracked they will be dressed, repaired or replaced.
 - 15.7 When faces of hammers, sledges, or similar tools become chipped or rounded they will be repaired or replaced.
 - 15.8 Wood handles that are loose, cracked, or splintered will be replaced. Taping or winding with wire will not be permitted.
 - 15.9 All files, rasps, and other hand tools that have a sharp tang will not be used without approved handles.
 - 15.10 Tools will not be stored or left lying where they present a hazard to other employees.
 - 15.11 Before making adjustments or changing air tools (unless equipped with quick-change connectors) the air will be shut off at the air supply valve ahead of the hose. The hose will be bled at the tool before breaking its connection.
 - 15.12 Practical jokes with compressed air are strictly forbidden. Compressed air entering or blown against the body may result in serious injury or death.

- 
- 
- 
- 15.13 Compressed air will not be used for cleaning purposes except where reduced to less than 30 psi and then only with sufficient protective equipment such as eye protection.
 - 15.14 Compressed air will not be used to clean wearing apparel or directed toward any part of the employee's body.
 - 15.15 The use of hoses for hoisting or lowering of air tools will not be permitted.
 - 15.16 Portable electric tools (except battery-powered drills, saws, etc.) will be effectively grounded at all times while connected to a power source. The insulation on hand tools will not be depended on to protect users from shock.
 - 15.17 All tools will be used with the correct shield guard or attachment, and properly adjusted as recommended by the manufacturer or as required by OSHA.
 - 15.18 Push sticks or other protective devices will be used when pushing stock into or through power tools such as bench saws, band saws, planers, etc. Employees will keep their hands from within the proximity of power driven cutting devices wherever possible.
 - 15.19 Employees will not operate or work near unguarded, revolving shafts, augers, etc., while wearing loose clothing and/or jewelry.
 - 15.20 Powder Actuated Tools (Tools which use a powder charge for fastening). Only employees who have been trained in its use will be allowed to operate a powder

actuated tool, such as a Hilti gun. See Divisional Safety Representative for details.

SECTION SIXTEEN

Electrical

- 16.1 When performing maintenance* or repair on electrically powered work equipment or machinery, the power service to such equipment or machinery will be locked out, tagged out, or disconnected. The employee(s) performing such work are responsible to see that the power is locked out or otherwise disconnected.

** Maintenance would include, but is not limited to, replacing bits, blades, tools, and dies.*

- 16.2 Only qualified and authorized employees shall work on energized electrical systems and parts and only in compliance with that Division's electrical safety program.
- 16.3 Extension cords. Portable cord and plug connected equipment and flexible cord sets (extension cords) shall be visually inspected before use on any shift for external defects (such as loose parts, deformed and missing pins, or damage to outer jacket or insulation) and for evidence of possible internal damage (such as pinched or crushed outer jacket). Cord and plug connected equipment and flexible cord sets (extension cords) which remain connected once they are put in place and are not exposed to damage need



not be visually inspected until they are relocated. Flexible cords are generally for temporary use and may not be used in place of permanent wiring.

All 120-volt, single-phase, 15 and 20 ampere receptacle outlets on construction sites, which are not a part of the permanent wiring of the building or structure and which are in use by employees, or cords used outdoors or in damp or wet locations shall have approved ground-fault circuit interrupters for personnel protection...

- 16.4 A three (3) feet, area must be kept clear in front of all Electrical panels.



SECTION SEVENTEEN

Office Safety





- 17.1 All employees will be familiar with the location of fire extinguishing equipment on their floor or work area.
- 17.2 All employees will be familiar with the location of fire alarm pull stations on their floor or work area.
- 17.3 Employees will not place material or equipment where it will obstruct exits, fire extinguishers, light switches, and fuse boxes. Areas in front of fire extinguishers must be kept clear.
- 17.4 Care will be used in walking on waxed floors, more particularly if floors or shoes are wet.



- 17.5 Running in building and parking areas is prohibited.
- 17.6 When ascending or descending stairways, always use handrails where provided.
- 17.7 Defective floor covering, stair treads, or rough spots should be reported at once for repairs.
- 17.8 Chairs, wastebaskets, electrical cords, and other articles will not be placed or left in aiseways where they constitute a tripping hazard.
- 17.9 Fans will be kept out of aisles and placed where they will not be a hazard.
- 17.10 All defective electrical fixtures such as plugs cords, etc., must be reported immediately and will not be used until repaired.
- 17.11 Good housekeeping will be practiced. Spills and other slipping hazards will immediately be wiped up or reported.
- 17.12 Filing drawers, desk drawers, cabinet drawers, doors to storage areas and closets will be kept closed except when actually attended.
- 17.13 Fire doors and security doors will not be propped open or rendered inoperable.
- 17.14 Care should be used in pulling out top drawers of filing cabinets to avoid tipping of the file case. At no time will two file drawers in the same case be pulled out at one time.
- 17.15 Boxes, chairs, or other makeshift devices will not be used for climbing or to reach elevated places.



- 
- 17.16 Furniture and equipment will be kept in good repair. Casters in chairs and other portable equipment should be fastened so they will not fall out. Any defects should be reported immediately.
- 17.17 Care should be used in being seated on a chair with casters. (It might roll out from under you.) Chairs with casters will not be used as a means of locomotion over office floors or as a truck to move equipment or material. When sitting in a straight chair, all four legs of the chair must be on the floor.
- 17.18 Adjustments to machinery will not be made with the machine running. Guards and protective devices will not be removed or rendered inoperable.
- 17.19 Cleaners and solvents used by office personnel should be of the approved type and will be used with care and with adequate ventilation. Such products will be properly stored in the proper-labeled container when not in use.
- 17.20 Paper cutters will be used with caution. The cutter blades will be fully closed when not in use, unless designed to lock in the open position.
- 17.21 Portable heating devices are prohibited in all areas of the organizations with the exception to company approved devices. These devices are approved by facility management. Please contact them for more information about heating devices for your work area.
- 
- 

- 17.22 All other appliances must be approved by Facility Management.

SECTION EIGHTEEN

Ergonomics



- 18.1 “Ergonomics” generally refers to the analysis of the job environment and tasks and the employee’s anatomical, physiological, and psychological characteristics.
- 18.2 The company will take reasonable actions to reduce risks associated with Musculoskeletal Disorders (MSD). An MSD is any physical disorder that results from or is aggravated by the cumulative effect of stress to tendons, lubrication of tendon sheaths and related bone, muscles, nerves of the hands, wrists, elbows, shoulders, neck and back.
- 18.3 If an employee feels he/she may be suffering from an MSD or has concerns about the ergonomic aspects of his/her work or work environment, he/she should report this to the supervisor or the division safety representative.
- 18.4 Upon receiving notification of a potential ergonomics issue, the supervisor and the division safety representative will review the matter. In addition, the division safety representative will include a qualified ergonomic professional in this review if needed.
- 18.5 The employee will receive feedback on the status of the issue from the supervisor or the division safety representative.

- 
- 18.6 Proper lifting techniques shall always be utilized and employees are encouraged to report situations where unsafe lifting technique is required.

SECTION NINETEEN

Confined Space Entry

Confined Space Entry must comply with Division and Regulatory requirements

- 
- 
- 19.1 Confined space refers to a space which by design has limited openings for entry and exit, unfavorable natural ventilation which could contain or produce dangerous air contaminants, and which is not intended for continuous employee occupancy. Confined spaces include, but are not limited to storage tanks, pits, vats, degreasers, boilers, ventilation and exhaust ducts, sewers, tunnels, underground company vaults, and pipelines.
- 19.2 Employees should not enter a confined space unless properly trained and authorized by their divisional safety representative.

SECTION TWENTY

Excavation and Trenching

Excavation and Trenching must comply with Division and Regulatory requirements

- 20.1 Citizens' will comply with all applicable IOSHA "Excavation" rules. See division trenching and excavation procedures for

more information. All trenches must be approved by a “competent person” before entering.

SECTION TWENTY - ONE

Energy Gas Operations Requirements

21.1 Hard hats and vests approved and furnished by the company, will be worn by all employees as follows:

Hard hat and Vest

- All maintenance employees - when on a job site, outside the vehicle
 - Exceptions
 - Welders during welding operations
 - Non Flame-retardant vests must not be worn when in a gaseous atmosphere
 - When on break outside of a defined hazard zone (see below).
 - Employees must have PPE within reach during these exceptions
- All employees - Code Red
- All employees - Working fire or fire investigation
- All employees - Disaster site such as tornado, flood, etc.
- All employees - When working in a defined hazard zone (see below).
- All employees - When working in a posted construction area

21.2 Traffic Vest

- Class II vest, jacket or outerwear
- Working in the right of way, including obtaining

- 
- tools or materials on the street-side of a vehicle
 - Working in a parking lot
 - Exposed to vehicular traffic

21.3 Traffic Control - Traffic control devices, signs, and channelizing devices (cones, barrels, barricades, etc.) alert and warn motorists of hazards created by construction or maintenance activities in or near the roadway. Due to the variety of conditions encountered with each unique work area, The Manual on Uniform Traffic Control Devices (MUTCD) should be followed when setting up and maintaining traffic control zones.

21.4 Hard Hat - Pipe Yard and other areas designated as “Hard Hat Required”.

21.5 Hazard Zone:

A Hazard Zone is defined as follows:

The larger distance of the following:

- A radius of 25 feet of any piece of equipment (Backhoe, work truck, dump truck) associated with the work being performed. (See Example 1)
 - The farthest reach of any one piece of equipment on the jobsite (Cranes etc.). (See Example 2)
- 

Example 1

A radius of 25 feet of any piece of equipment (Backhoe, work truck, dump truck) associated with the work being performed

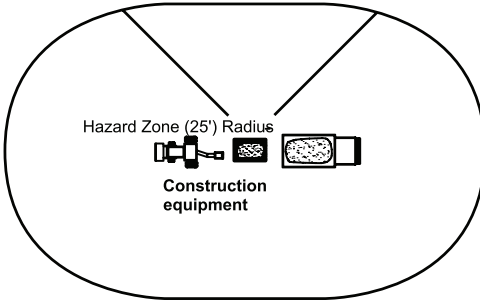

Example 2

The farthest reach of any one piece of equipment on the jobsite (Cranes etc)

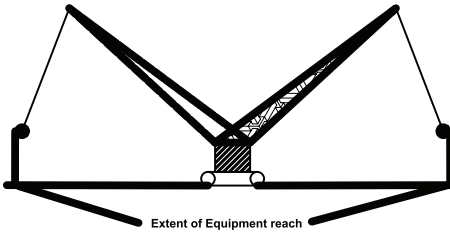

Hazard Zone Examples

21.6 Hard hats also required:

- a) When working in the field at the Underground Storage facilities.
- b) When entering the LNG facilities. (Hats available at the office.)
- c) When working in any area not specified above, as directed by proper authority.



Bandannas: Headwear of this type shall not interfere with hard hat fit; loose ends beyond knot shall be secured inside outer shirt or jacket.

Exceptions:

- During lunch or break periods, provided the employee does not remain in a hazardous area.
- When inside office areas, an enclosed cab of a vehicle, construction equipment, or other similar equipment.
- When in the judgment of supervision, a specific work area makes the use of a hard hat impractical.

21.7 Eye Protection: Eye protection approved by the Company will be worn by all employees when performing the following tasks:

- a) The breaking or chipping of stone, concrete, brick, asphalt, paint, pipe coatings, metal, frozen ground, or other similar material.
- b) The operation of a cad welder.
- c) Power grinding, buffing, wire brushing, sanding, or powder actuated tool use.

- 
- 
- 
- d) The removal of fittings or the use of tapping machines, or any other procedure where the possibility of escaping high pressure gas or compressed air is present.
 - e) A job site requiring fire extinguisher(s) to be manned on a standby basis.
 - f) During the handling or working around caustic chemicals and corrosion inhibitors.
 - g) Any other operation when in the judgment of supervision, the possibility of eye injury exists.
 - h) When entering any area where it has been designated that eye protection is required, i.e., industrial plants, construction projects, see divisional requirements for more information.

21.8 **Welding Hoods: Contact Departmental Safety Representative for safety requirements.**

21.9 **Respirators: Contact Departmental Safety Representative for safety requirements.**

21.10 **Jewelry Restrictions: Employees shall not wear watches, rings, or any other jewelry when performing any task that could result in an injury by these jewelry items getting caught on or smashed in the work area. Jewelry prohibited tasks would include the following:**

- Any Citizens' employee working on equipment or machinery where jewelry could come into contact with moving

parts. This would include, but would not be limited to, anyone working on boring or drilling equipment, rotary equipment such as lathes, compressors or pumps, or other pieces of equipment that move such as powered gates, hoists, etc.

- Anyone working in a location where their hands are near or could come into contact with energized electrical parts or equipment.
- Other tasks where jewelry could create an additional hazard for the employee.

Employees should check with their supervisor for specific job functions that may create a hazard if wearing jewelry. Jewelry shall not impede the proper use of PPE.

Certain Gas Division employees will be required to wear cotton outer wear uniforms as provided and all cotton or natural fiber under garments.

21.11 Hair: If shoulder length or longer, it shall be braided, tied, or tucked inside collar or under hardhat when working around moving or rotating equipment and must not interfere with the effectiveness of the hardhat.

21.12 Many tasks require the use of personal protective equipment and employees must be trained in the selection, use, maintenance, donning and doffing of PPE. See your divisional safety representative for more information.

SECTION TWENTY - TWO

Energy Thermal Operations Requirements



Note: Jewelry or any type of personal accessory shall not impede the proper use of PPE.



Bandannas: Headwear of this type shall not interfere with hard hat fit; loose ends beyond knot shall be secured inside outer shirt or jacket.

22.1 Head Protection: Hard hats approved and furnished by the Citizens Energy Group, will be worn by Citizens' employees in designated areas or as required by divisional standards or task hazard assessments. PPE Exceptions: hard hats must be worn at all times at Perry K except where noted below:

- a) Parking Lots
- b) Locker Room
- c) Restrooms
- d) Lunchrooms
- e) Offices
- f) Control Rooms
- g) Walking through the turbine room to the passenger elevator
- h) Walking to and from the locker room at the start or end of the shift

Hard hats are required at Chilled Water any time there is a risk of head injury from overhead hazards and includes any time any employee works from scissors lifts, man lifts or boom lifts or other times where overhead hazards exist.

- 
- 
- 
- 22.2 Safety glasses: Safety glasses with side shields or full cover goggles are required at Perry K and at all Chilled Water Plants. Tinted lenses (sunglasses) may be worn at the discretion of the area supervisor for specific job tasks. However, sunglasses shall not be worn for normal maintenance or operating functions. Contact lenses shall not be worn in the Perry K plant.
- 22.3 Hearing Protection: Approved hearing protection will be worn by Citizens' employees in designated areas or as required by divisional standards. At Perry K, at all times except as noted above for exceptions to hard hat requirements.
- 22.4 Welding Hoods: Welding hoods, or welding goggles, will be furnished by the Citizens' and will be used as required by divisional standards.
- 22.5 Sand Blasting Hoods: Sand blasting hoods will be furnished by the Citizens' and will be worn by employees engaged in sandblasting.
- 22.6 Respiratory Protection: Proper breathing apparatus will be furnished by the Citizen' sand will be used by employees as required by Citizen' sand State and Federal Regulations.
- 22.7 Appropriate Footwear for Employees: Perry K (Steam) employees are required to wear 6" safety toed boots when working in the Plant or on the Distribution system. Chilled Water employees are required to wear safety toe shoes.

- 
- 
- 
- 22.8 Safety vests: Safety vests or outerwear are required when employees are exposed to moving vehicular traffic while on a Citizens' worksite, or when employees are engaged in traffic control at a Citizens' worksite.
 - 22.9 FR Clothing: Employees engaged in work where there is a potential for a fire hazard will be required to wear flameproof coveralls and hoods and other PPE as furnished and required by Citizens.
 - 22.10 Gloves: Protective gloves, furnished by the Citizens Energy Group, will be worn when engaged in specified work operations.
 - 22.11 Welding: Leather welding sleeves, furnished by Citizens, will be worn when engaged in welding.
 - 22.12 Other requirements for working at Perry K plant include a company furnished uniform with long sleeve shirt, safety glasses with permanent attached side shields, and employees will carry with them a battery powered light.
 - 22.13 Other PPE may be required for specific tasks.

SECTION TWENTY - THREE

Water and Wastewater Operations Requirements

Note: Jewelry or any type of personal accessory shall not impede the proper use of PPE.

Bandannas: Headwear of this type shall

not interfere with hard hat fit; loose ends beyond knot shall be secured inside outer shirt or jacket.

23.1 Hard Hats: Approved hard hats are provided to employees and are to be worn when working or visiting areas where there is a reasonable probability of injury that can be prevented by such equipment. Employees are responsible for visually inspecting their hard hat for any signs of dents or cracks that could reduce the degree of safety originally provided. Any deficiency noted should be reported and the hard hat replaced. Hard hats are required to be assembled and worn per the manufacturer's instruction. Some of the many areas that require employees to wear a hard hat include, but are not limited to:

- a) All construction and maintenance sites
- b) All basins, filters, pits, trenches, and vaults
- c) Pipe Yard and other areas designated as "Hard Hat Required"
- d) Any "hazard zone" as defined above in Section 21.3
- e) Near material handling equipment
- f) Where there is danger of falling or flying objects or the danger of striking one's head.

23.2 Safety Glasses, Goggles and Face Shields: Citizens provides employees with eye and face protection when there is a reasonable

likelihood of injury that can be prevented by such equipment. Appropriate eye or face protection shall be worn when exposed to hazards from molten metal, liquid chemicals, gases or vapors, or flying particles. Prescription safety glasses must have side shields. Some of the many jobs requiring eye and/or face protection include, but are not limited to:

- Breaking pavement, rock, etc.
- Buffing or caulking
- Chemical handling
- Chipping, drilling, grinding, lathe work, machine threading
- Construction and maintenance operations
- Pipe cleaning or scraping
- Pouring or handling cement
- Sand blasting or spray painting
- Using jack hammer, power saws, and drills
- Vacuuming valve boxes and curb boxes
- Wastewater operations and investigations of wastewater overflow and back-ups
- Welding, wire brushing
- Working under vehicles

23.3 Safety Shoes: Employees exposed to foot injuries from falling or rolling objects are required to wear safety shoes that meet ASTM Standards for foot protection.

23.4 Respiratory Protection: Proper breathing apparatus will be furnished by Citizens' and will be used by employees as required by Citizens' and State and Federal Regulations.

23.5 Traffic Vest: Traffic safety vests that meet ANSI standards must be used as follows:

- Working in the right of way, including obtaining tools or materials on the street-side of a vehicle
- Working in a parking lot
- Exposed to vehicular traffic

23.6 Traffic Control: Traffic control devices, signs, and channelizing devices (cones, barrels, barricades, etc.) alert and warn motorists of hazards created by construction or maintenance activities in or near the roadway. Due to the variety of conditions encountered with each unique work area, The Manual on Uniform Traffic Control Devices (MUTCD) should be followed when setting up and maintaining traffic control zones.

23.7 Wastewater Exposure: Employees should avoid direct contact with sanitary wastewater to prevent exposure to waterborne pathogens and biohazards associated with wastewater. Rubber gloves and protective clothing should be worn. Employees should wash their hands frequently with anti-bacterial soap.

SECTION TWENTY-FOUR

Shared Field Services Requirements

Note: Jewelry or any type of personal accessory shall not impede the proper use of PPE.

Bandannas: Headwear of this type shall not interfere with hard hat fit; loose ends beyond knot shall be secured inside outer shirt or jacket.

24.1 Respiratory Protection: Proper breathing apparatus will be furnished by Citizens' and will be used by employees as required by Citizens' and State and Federal Regulations.

24.2 Safety glasses: Employees with prescription glasses shall be worn with side shields or full cover goggles. Tinted lenses (sunglasses) may be worn at the discretion of the area supervisor for specific job tasks.

24.3 Hair: If shoulder length or longer, it shall be braided, tied, or tucked inside collar or under hardhat when working around moving or rotating equipment.

24.4 Traffic Vest: Safety vests are required when employees are exposed to moving vehicular traffic while on a Citizens' worksite or when employees are engaged in traffic control at a Citizens' worksite. Vest shall be worn when working in the right of way, including obtaining tools or materials on the street-side of a vehicle or working in a parking lot.

Hard hat and Vest

- All employees - Code Red
- All employees - Working fire or fire investigation
- All employees - Disaster site such as tornado, flood, explosions, other.
- All employees - When working in a defined hazard zone (See Below).

- All employees - When working in a posted construction area

24.5 Head Protection: Hard hats approved and furnished by Citizens Energy Group, will be worn by Citizens' employees in designated areas or as required by divisional standards.

Headwear (i.e., bandannas) shall not interfere with hard hat fit; loose ends beyond knot shall be secured inside outer shirt or jacket.

24.6 Hearing Protection: Citizens' approved hearing protection will be worn by Citizens' employees in designated areas or as required by divisional standards.

24.7 Protective Clothing - General:

- a) In addition to the personal protective equipment, employees will provide and wear sufficient clothing and apparel to protect themselves from the elements and weather conditions such as extreme cold, exposure to the sun, etc.
- b) Appropriate footwear for Employees: All employees will wear appropriate footwear that will provide an adequate and secure footing. When required, full toe protectors will be furnished by the company and will be worn by employees.

Many tasks require the use of personal protective equipment and employees must be trained in the selection, use, maintenance, donning and doffing of PPE. See your divisional safety representative for more information.

SECTION TWENTY-FIVE

Emergency Action Plan

- 25.1 During an emergency incident (i.e. fire, severe weather, bomb threat, active shooter, etc.), the facility's and/or department's Emergency Action Plan (EAP) will be implemented and followed.

Occupational Treatment Centers

U.S. Health Works Medical Group

**1101 Southeastern Avenue
Indianapolis, IN 46202
8:00am - 5:00pm, Monday - Friday
(317) 955-2020**

**5603 West Raymond St.
Indianapolis, IN 46241
OPEN 24hrs. 7 days a week
(317) 241-8266**

Important Emergency Numbers:

Marion County (317 area code)

Other Emergency numbers

Ambulance:911
Distribution Dispatcher: 927-6000
CEIS (Athletic Trainer):..... 790-7795
Energy - Gas Safety: 927-6006
Energy - Thermal Safety: 927-4693
Corporate Office Safety: 927-6006
SFS Safety: 927-4593

Water Safety: 263-6342
Prospect Guard: 264-8707
Thermal Safety Office: 927-4693
Thermal (Steam) Control Room: 261-8804
Thermal (Chilled Water) Control Room: .. 236-6700

Hamilton County

Westfield After-Hours Treatment:
(317) 773-0760 (Riverview Hospital)

Greene County

Emergency Ambulance
Service: (812) 384-4457 Bloomfield, IN
Greene Co., General Hospital
(Emergency Room): (812) 847-2281 Linton, IN
Bloomington Hospital & Healthcare System:
Center for Occupational Health
 Promptcare West: (812) 353-3443
 Promptcare East: (812) 353-6888
Lyons Medical Center: ... (812) 659-3395 Lyons, IN
Sheriff Dept.: (812) 384-4411 Bloomfield, IN
Gas Operations
Safety Office: (317) 927-4693 Indianapolis, IN
Cell Phone for
Emergencies: (812) 887-5029 Greene Co. IN
Worthington Family Medicine: (812) 875-2000

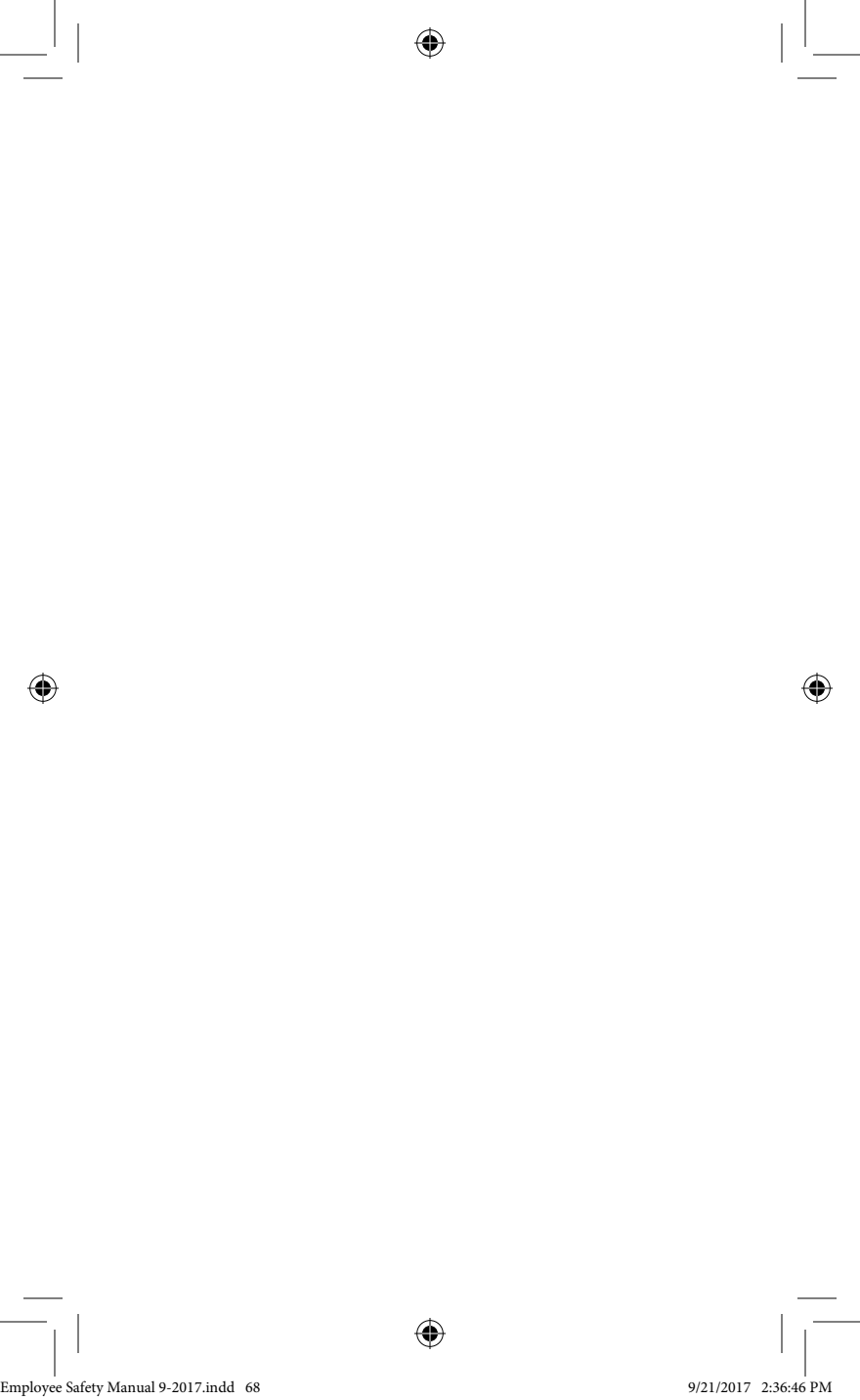

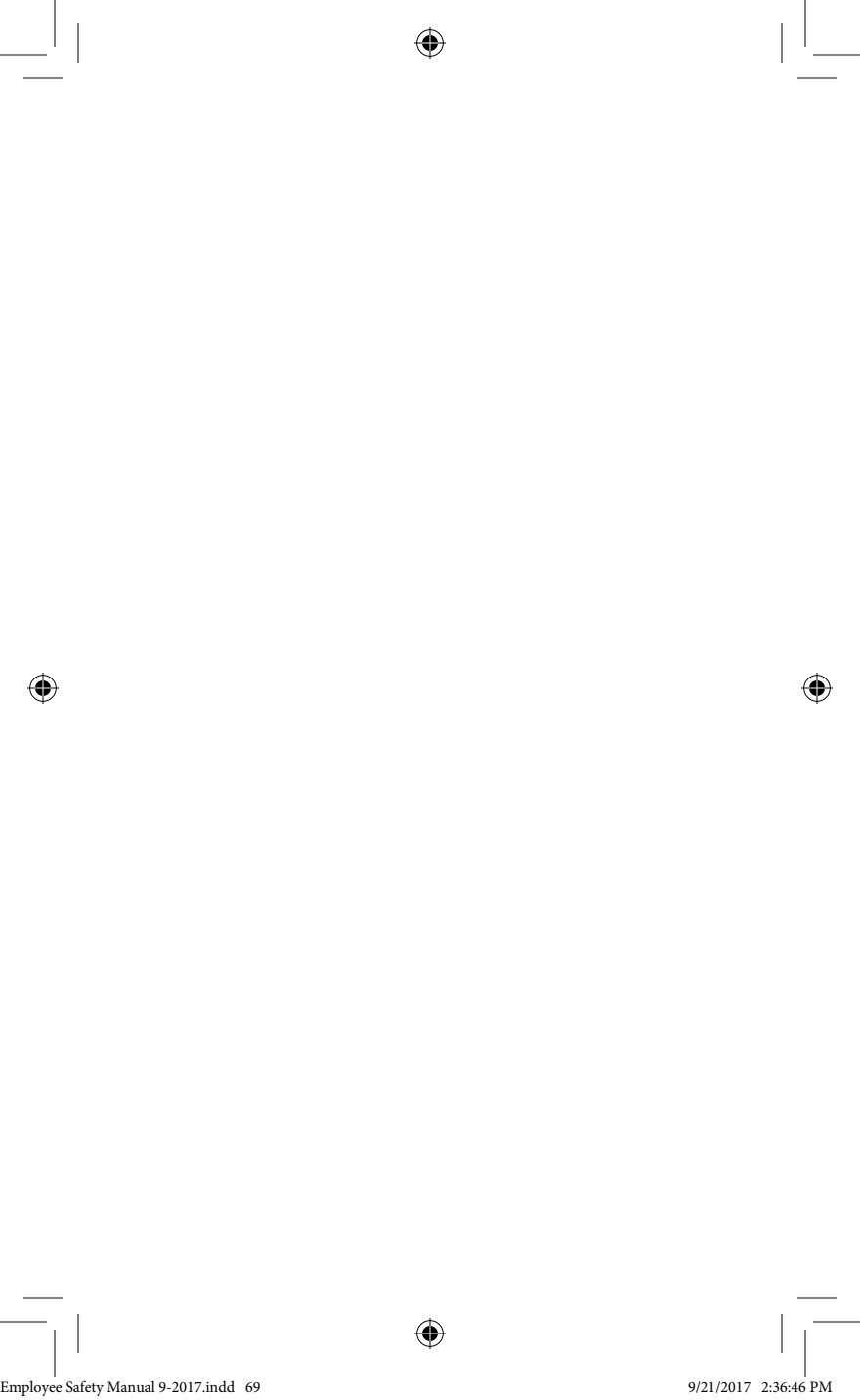

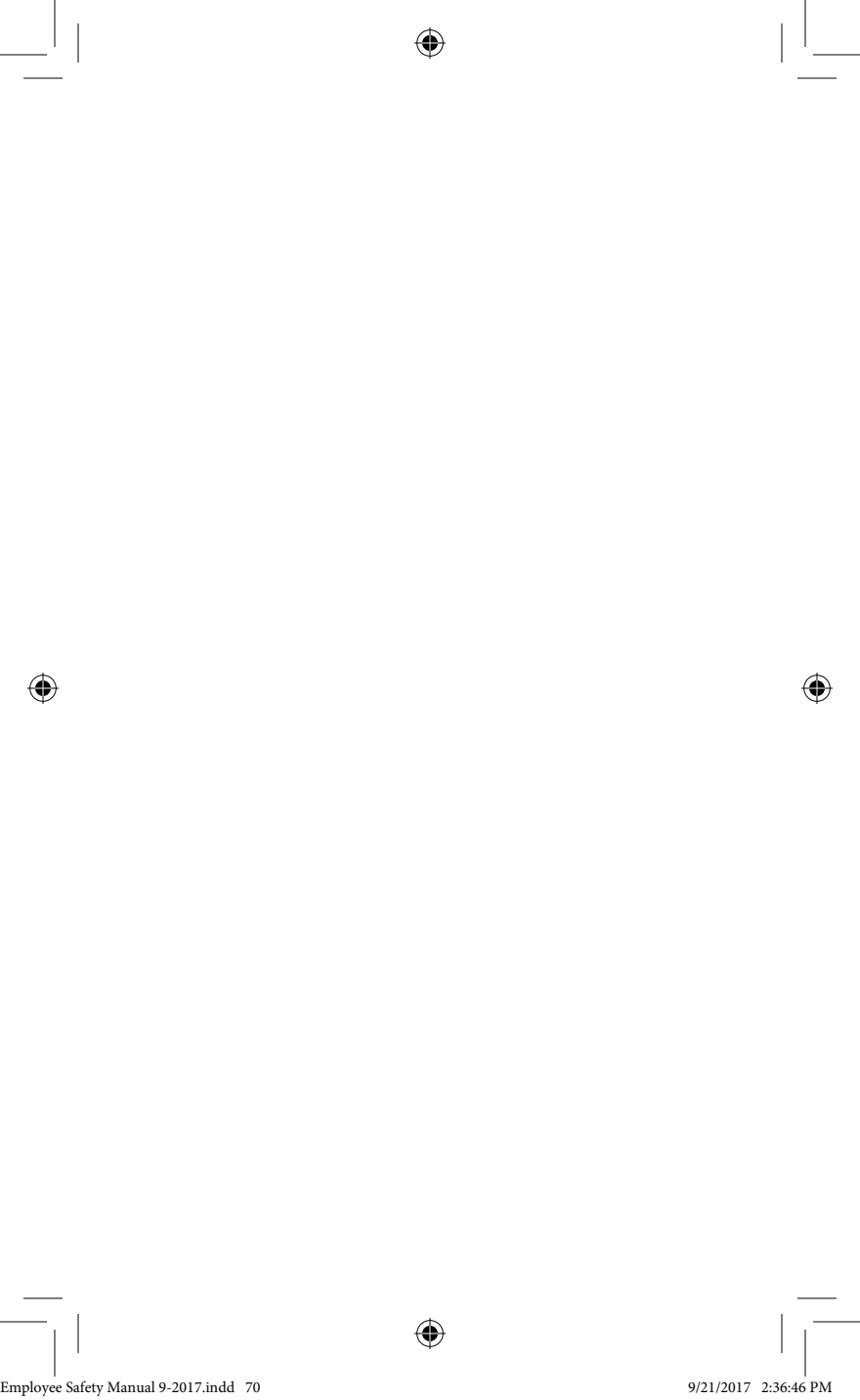

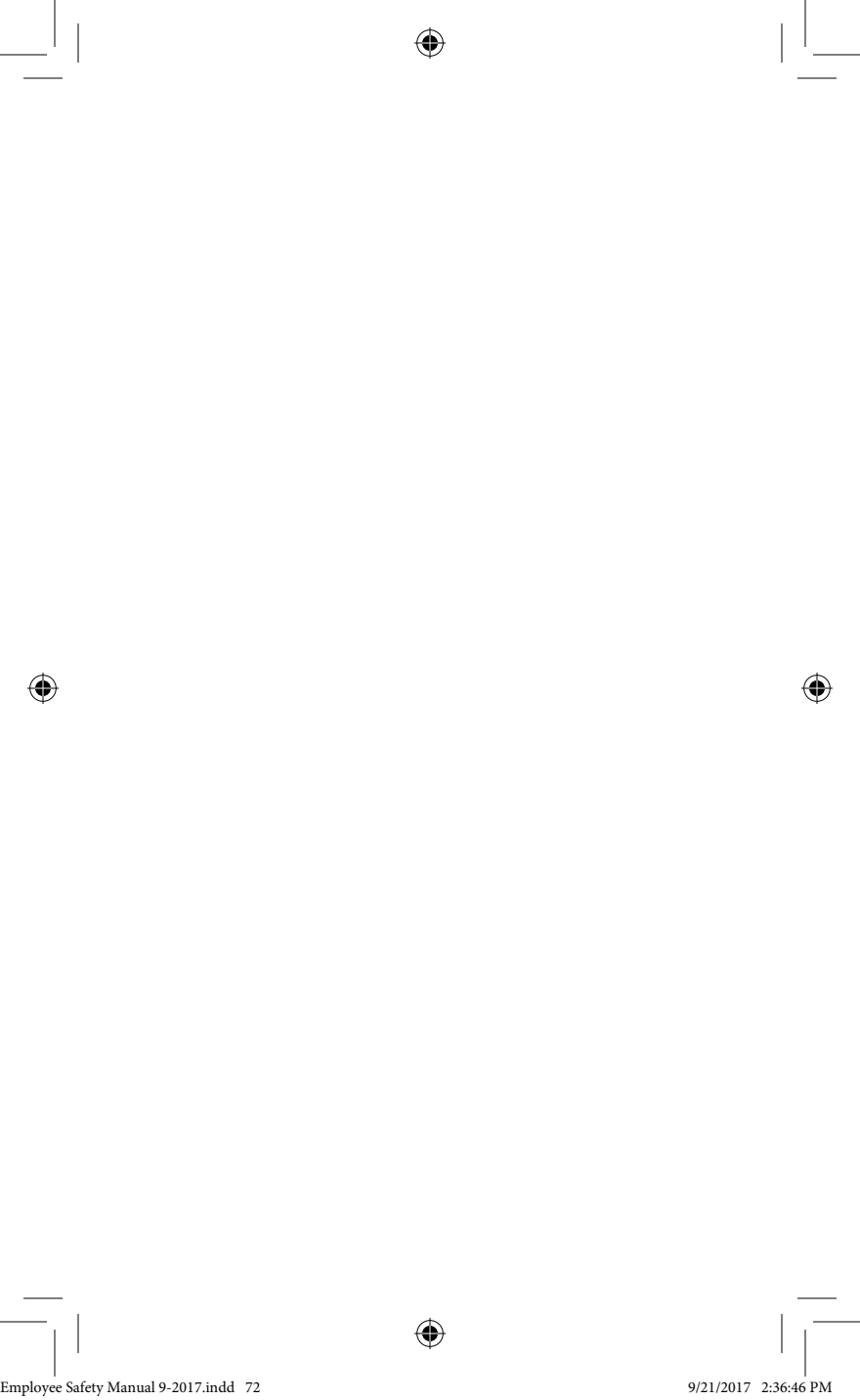

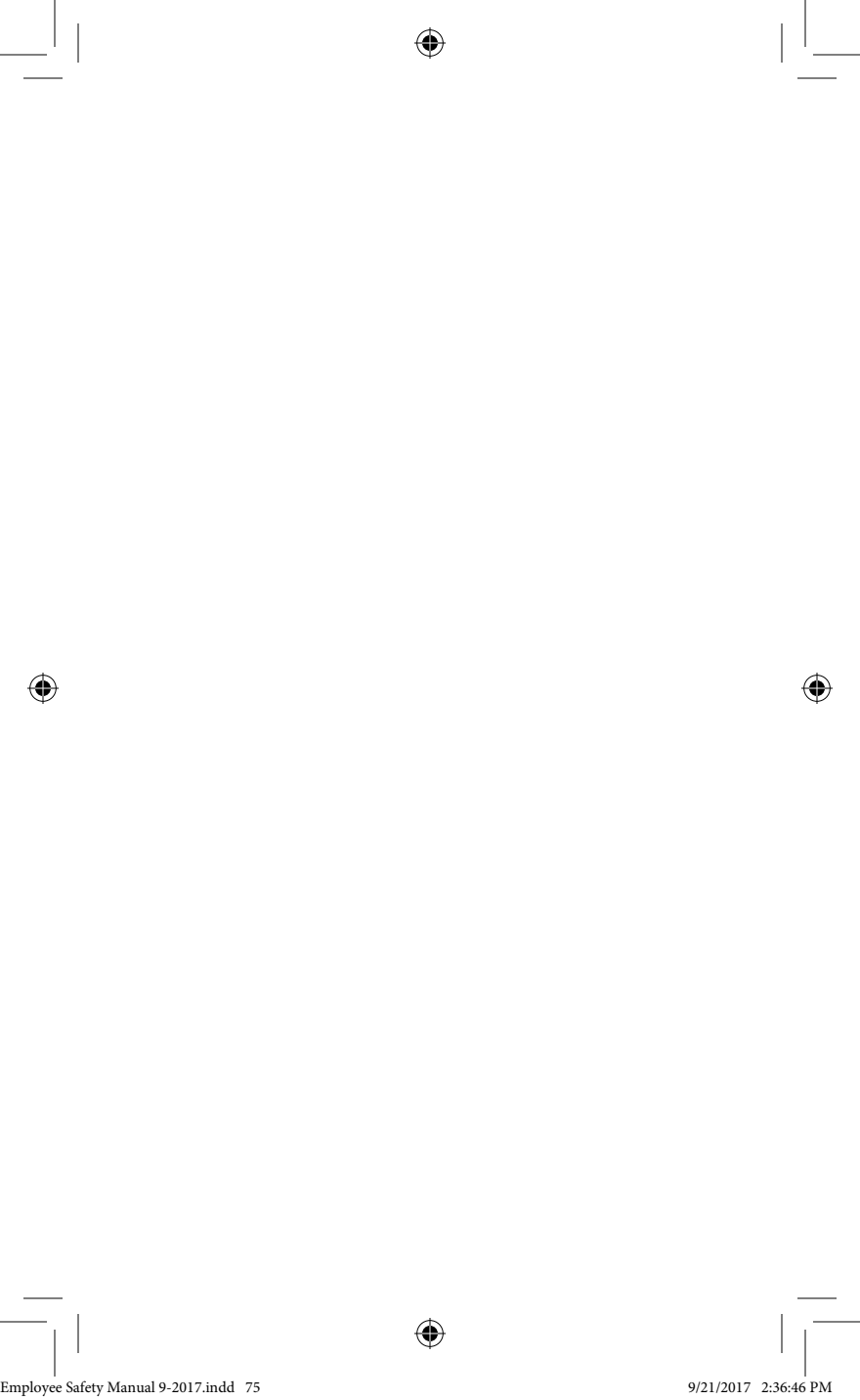

Appendix D
Institutional Controls Within Site 0153 General Boundary

Institutional Controls Within Site 0153 General Boundary (bound generally by 35th Street to the north, Holt Road to the west, Washington Street to the south, and Central Avenue to the east), Indianapolis, Indiana.

Facility Name	Address	Control Type*	Date Recorded	Control Method**	Affected Media	Constituents of Concern***
Kessler, LLC	2966 Kessler Blvd.	ERC	11-Dec-20	RES Use Restriction; GW Use Restriction; Ag Use Restriction; Engineering Control OM&M	Subsurface Soil; Groundwater; Vapor	VOCs
GP-CM Lockerbie Partners, LLC	303 N Alabama & 324 E New York St	ERC	17-May-19	GW Use Restriction	Groundwater	VOCs
Trex Enterprises	3140 N Meridian St	ERC	24-Nov-20	Soil Management Plan	Soil	Arsenic
D A Lubricant Company	1331 W 29th St	ERC	07-Jul-10	GW Use Restriction; RES Use Restriction	Groundwater; Subsurface Soil	PAHs; Petroleum; TPH
MPLX Terminals LLC	1304 Olin Ave	ERC	01-Mar-10	Excavation Notice Required; GW Use Restriction; RES Use Restriction	Groundwater; Subsurface Soil	Petroleum; SVOCs; TPH
Pulliam Partners II LLC	307 N Pennsylvania St	ERC	14-May-15	Prohibit Monitoring Interference; VI Contingency	Air (Indoor); Soil Gas (Vapor)	VOCs
FINISHMASTE R INC	923 N Meridian St	ERC	25-Jul-08	VMS; Ag Use; Excavation Notice Required; GW Use Restriction	Groundwater; Soil Gas (Vapor); Subsurface Soil; Surface Soil	Metals; VOCs
Irving Material Incorporated	1100 Burdsal Pkwy	ERC	23-Sep-14	GW USE Restriction	Groundwater	Metals
Speedway 3761	1404 W Washington St	ERC	16-Oct-17	GW Use Restriction; RES Use Restriction	Groundwater; Subsurface Soil	VOCs
Speedway LLC	3437 Lafayette Rd	ERC	20-Oct-04	GW USE Restriction; RES Use Restriction; Restricted Excavation Area; Other	Groundwater; Subsurface Soil	Petroleum
Saint Clair Properties Limited Warehouse	1100 W 21st St	ERC	11-Mar-16	VMS; Excavation Notice Required; GW Use Restriction; RES Use Restriction	Groundwater; Subsurface Soil; Surface Soil	PAHs; VOCs
Hittle Machine	2122 Dr Martin L King Jr St	ERC	05-Mar-21	Engineering Control OM&M; Other Restriction ; RES Use Restriction	Soil Gas (Vapor)	VOCs
Speedway Waste Water Treatment Plant	4251 W Vermont St	Deed Notice	13-Dec-99	Soil or Vegetative Cap	Solid Waste	
Henleys Kustom Painting	1310 N Capitol Ave	ERC	29-Mar-21	GW Use Restriction; Other Restriction	Groundwater	VOCs

Dickey & Son Machine & Tool Company	2450 Turner Ave	ERC	26-Oct-10	Soil or Vegetative Cap; Ag Use; Excavation Notice Required; GW Use Restriction; RES Use Restriction; Other	Groundwater; Soil Gas (Vapor); Subsurface Soil; Surface Soil	Metals; PAHs; Petroleum; VOCs
Capitol Commons Simon Headquarters	225 W Washington St	ERC	10-Nov-04	Excavation Notice Required; GW Use Restriction; RES Use Restriction; Restricted Excavation Area	Groundwater	VOCs
Quick Exchange 100	2504 W Washington St	ERC	29-Mar-12	GW Use Restriction	Groundwater; Subsurface Soil	Petroleum; TPH
North 40 Minute Cleaners	3360 N Illinois St	ERC	27-Oct-17	GW Use Restriction; Other Restriction	Groundwater	VOCs
Beveridge Paper Mill	717 W Washington St	Deed Notice	13-Jun-01	GW Use Restriction	Groundwater; Subsurface Soil; Surface Soil	Metals; PCBs; SVOCs; VOCs
Stuarts Moving & Storage	2058 Dr Martin Luther King Jr St	ERC	30-Nov-20	GW Use Restriction; VI Contingency	Groundwater; Soil Gas (Vapor)	Metals; VOCs
McFarling Foods Incorporated	333 W 14th St	ERC	26-Jul-19	Ag Use; GW Use Restriction; Land Activity Monitoring; RES Use Restriction; Other	Concrete Surface; Groundwater; Subsurface Soil; Surface Soil	VOCs; Petroleum
J Solotken & Company Incorporated	101 S Harding St	ERC	31-Jul-12	Paved or Concrete Cap; Excavation Notice Required; GW Use Restriction; Restricted Excavation Area; Other	Groundwater; Subsurface Soil; Surface Soil	Metals; VOCs
Amoco Service Station	3001 N Meridian St	ERC	20-Sep-07	Ag Use; Excavation Notice Required; GW Use Restriction; RES Use Restriction; Restricted Excavation Area	Groundwater; Subsurface Soil	Metals; TPH; Petroleum;
Herff Jones Incorporated	1411 N Capitol Ave	ERC	18-Apr-05	GW Use Restriction; RES Use Restriction; Soil Handling and Disposal; VI Contingency	Subsurface Soil	Inorganic Non-Metallic; Other; PAHs; VOCs
Philip K Watts	2330 N Meridian St	ERC	02-Aug-11	Excavation Notice Required; GW Use Restriction; RES Use Restriction	Groundwater; Subsurface Soil	Petroleum; SVOCs; TPH
Rumpke Indianapolis Transfer Station	2101 N Montcalm St	ERC	15-Jul-11	Ag Use; GW Use Restriction; RES Use Restriction	Groundwater; Subsurface Soil; Surface Soil	Metals; SVOCs; VOCs
VACANT PROPERTY	2878 Clifton St	ERC	14-Dec-11	GW Use Restriction	Groundwater	Metals; VOCs
Phillips 66	2425 Lafayette Rd	ERC	11-May-05	GW Use Restriction; RES Use Restriction	Groundwater; Subsurface Soil	Petroleum
66 Food Mart	2202 N Delaware St	ERC	13-Oct-17	GW Use Restriction; RES Use Restriction	Groundwater	Petroleum

500 Liquors	2308 W 10th St	ERC	14-Dec-11	GW Use Restriction	Groundwater	VOCs
Hedback Corporation	1835 N New Jersey St	ERC	16-May-19	GW Use Restriction	Groundwater	VOCs
Disc Graphics Incorporated	1160 W 16th St	ERC	24-Aug-05	GW Use Restriction; RES Use Restriction	Groundwater	VOCs
Shell Oil Facility F	2121, 2201 & 2219 W Michigan St	ERC	25-Jun-12	GW Use Restriction; Other Restriction ; RES Use Restriction	Groundwater	VOCs
Titan Homes	1534 Central Ave	ERC	08-Feb-18	GW Use Restriction	Groundwater	Metals; PAHs; VOCs
2455-57 North Delaware	2455 & 2457 N Delaware St	Order	19-Oct-06	VMS; GW Use Restriction	Groundwater; Soil Gas (Vapor)	VOCs
Church Property	2201 N Delaware St	ERC	20-Dec-07	Ag Use; Excavation Notice Required; GW Use Restriction; RES Use Restriction	Groundwater; Surface Soil	SVOCs; TPH; VOCs
Residential	2501-11 N Delaware St	ERC	18-Oct-06	VMS; Ag Use; Excavation Notice Required; RES Use Restriction	Groundwater; Subsurface Soil	TPH; VOCs
HOOVER GAS	2866 N Capitol Ave	ERC	14-Dec-11	GW Use Restriction; RES Use Restriction	Groundwater; Subsurface Soil	Petroleum
Michaelis Development LLP	1352 N Illinois St	ERC	10-Aug-15	Maintain Building Slab; VMS; Paved or Concrete Cap; GW Use Restriction	Groundwater; Soil Gas (Vapor); Subsurface Soil	VOCs
DO ALL COMPANY	1850 W 16TH ST	ERC	07-Jul-10	Paved or Concrete Cap; Ag Use; GW Use Restriction; RES Use Restriction	Groundwater; Subsurface Soil	PAHs; TPH
FR Indianapolis Partners LP	1013 & 1019 N Capitol Ave	ERC	09-Apr-08	Ag Use; GW Use Restriction; RES Use Restriction	Subsurface Soil	Petroleum; TPH
WTBU TV Building Former	2853 N Illinois St	Deed Notice	22-Dec-03	RES Use Restriction	Groundwater; Subsurface Soil; Surface Soil	Petroleum; SVOCs
Triangular Parcel Site	420 N Senate Ave	ERC	25-Jul-08	Soil or Vegetative Cap; Ag Use; Excavation Notice Required; GW Use Restriction	Groundwater; Subsurface Soil	PAHs; TPH; VOCs
Central State Hospital	2800 W Washington St	ERC	25-Apr-13	GW Use Restriction	Groundwater	Metals
Tuchman Cleaners 15	350 E New York St	ERC	15-Jan-19	GW Use Restriction; RES Use Restriction	Groundwater; Soil Gas (Vapor)	VOCs
2131-2151 N Meridian	2131-2151 N Meridian St	ERC	11-Nov-08	VMS; Ag Use; GW USE Restriction	Groundwater; Soil Gas (Vapor); Subsurface Soil	VOCs
2201 N Capitol	2201 N Capitol Ave	ERC	04-Aug-16	GW Use Restriction	Groundwater	PAHs
Morris Mabry	241 N Pennsylvania St	ERC	05-Oct-09	GW Use Restriction	Groundwater; Subsurface Soil	TPH
Greater Diversified Supply	1234 N Capitol Ave	ERC	20-Feb-13	Ag Use; GW USE Restriction; RES Use Restriction	Groundwater; Subsurface Soil	VOCs

West Michigan & Holmes	530 N Holmes Ave	ERC	11-Apr-14	Paved or Concrete Cap; Soil or Vegetative Cap; Ag Use	Subsurface Soil; Surface Soil	Metals; PCBs; SVOC
Herron Art Foundry	230 E 16TH ST	ERC	05-Jun-06	Ag Use; GW Use Restriction; RES Use Restriction	Groundwater; Subsurface Soil	Metals; PAHs; VOCs
Central Parking Corporation All Right Corp	269 W 16th St	ERC	30-Aug-12	Paved or Concrete Cap; Ag Use; GW Use Restriction; RES Use Restriction	Groundwater; Subsurface Soil	Metals; PAHs; VOCs
Winona Memorial Hospital	3232 N Meridian St	ERC	27-Jan-12	VMS; Paved or Concrete Cap; Ag Use; Excavation Notice Required; GW Use Restriction	Groundwater; Surface Soil	Metals; VOCs
LAZ Parking Lot	131 N Alabama St	ERC	27-Jul-17	GW Use Restriction; Other Restriction	Groundwater	PAHs; Petroleum; VOCs
Karstadt Reed Cleaners	1449 N Illinois St	Deed Notice	20-Nov-03	RES Use Restriction	Subsurface Soil	Petroleum
Cohn & Sons	1402 N Capitol Ave	ERC	14-Nov-06	Ag Use; Excavation Notice Required; GW Use Restriction; RES Use Restriction; Other	Groundwater; Subsurface Soil	VOCs
R&M Machine	284 N Belmont Ave	ERC	06-Jan-17	GW USE Restriction; VI Contingency	Groundwater; Soil Gas (Vapor); Subsurface Soil	VOCs; Petroleum
Bank One Parking Garage	101 N New Jersey St	ERC	24-May-11	VMS; Ag Use; GW Use Restriction; RES Use Restriction	Groundwater; Surface Soil	SVOCs; VOCs
Lohmann Property	2215 W 16th St	ERC	10-Mar-21	GW Use Restriction		
Superior Distributing	918 Ft Wayne Ave	ERC	13-Oct-14	Other; Paved or Concrete Cap; RES Use Restriction	Subsurface Soil; Surface Soil	Metals; SVOCs
State Discount Liquor	2502 N Delaware St	ERC	20-Sep-17	GW Use Restriction	Groundwater	VOCs
Gardner Building	350 W St Clair St	ERC	03-Aug-17	Excavation Notice Required; GW Use Restriction; Other	Groundwater; Subsurface Soil; Surface Soil	Metals; PAHs; VOCs
Fire Department and Credit Union	501 & 555 N New Jersey St	ERC	10-Jan-17	GW Use Restriction; Other Restriction	Groundwater	PAHs; VOCs
Cooprider Auto Service	1318 N Capitol Ave	ERC	29-Apr-21	GW Use Restriction; Other Restriction	Groundwater	VOCs
Lockerbie Property East	302 N East St	ERC	27-Jul-16	GW Use Restriction; VI Contingency	Groundwater; Soil Gas (Vapor)	VOCs
Lockerbie Property New York	437 E New York St	ERC	07-Oct-15	GW Use Restriction	Groundwater	Metals; SVOCs
Commercial Warehouse	1779 W 15th St	ERC	24-Jul-17	GW Use Restriction; Other Restriction	Groundwater	VOCs

Illinois Commercial Properties	3404-3444 N Illinois St	ERC	18-Sep-17	GW Use Restriction; Soil Handling and Disposal; Soil Restoration; Other	Groundwater; Subsurface Soil	Metals; PAHs; VOCs
Circle City Capital Property	305 N Harding St	ERC	04-Oct-18	GW Use Restriction	Groundwater	Metals
Turner Property	727 N Illinois St	ERC	23-Mar-18	GW Use Restriction	Groundwater	VOCs
Indianapolis Badge & Nameplate Company	25 Mclean Pl	ERC	09-Apr-19	GW Use Restriction; VI Contingency	Groundwater	VOCs
Turner Avenue Properties	2350 Turner Ave	ERC	12-Aug-19	GW Use Restriction; Other Restriction; RES Use Restriction	Groundwater; Subsurface Soil; Surface Soil	Metals; PAHs; VOCs

*Control Type Abbreviations: Environmental Restrictive Covenant (ERC)

**Control Method Abbreviations: Groundwater (GW) Use Restriction; Residential (RES) Use Restriction; Agricultural (Ag) Use Restriction; Vapor Intrusion (VI) Contingency; Maintain Vapor Mitigation System (VMS)

***Constituents of Concern Abbreviations: Volatile Organic Compounds (VOCs), Semi-volatile Organic Compounds (SVOCs); Polyaromatic Hydrocarbons (PAHs); Total Petroleum Hydrocarbons